



ONE SERIES

User, installation, and servicing instructions

6 ZONE INDUCTION RANGE

E161i & E163i

4 ZONE INDUCTION RANGE

E143i

Please read these instructions before use

DATE PURCHASED:

MODEL NUMBER:

SERIAL NUMBER:

DEALER:

SERVICE PROVIDER:

T101029

Rev 13

Dear Customer

Thank you for choosing Falcon Foodservice Equipment.

This manual can be downloaded from www.falconfoodservice.com or scan here:



IMPORTANT: Please keep this manual for future reference.

Falcon Foodservice Equipment

HEAD OFFICE

Wallace View, Hill foote Road, Stirling, FK9 5PY, Scotland

Phone: 01786 455200

PREVENTATIVE MAINTENANCE CONTRACT

To obtain maximum performance from this unit regular servicing of the appliance should be undertaken to ensure correct operation, it is functioning as intended, and safe to use. We recommend servicing in accordance with SFG20 Maintenance Schedules and as a minimum, after 2,500 hours of use, or annually, whichever comes first and that a maintenance contract be arranged with an appointed service contact. Visits may then be made at agreed intervals to carry out adjustments and repairs.



WEEE Directive Registration No. WEEE/DC0059TT/PRO

At end of appliance life, dispose of appliance and any replacement parts in a safe manner, via a licensed waste handler. Appliances are designed to be dismantled easily and recycling of all material is encouraged whenever practicable.

CONTENTS

1.0 SYMBOLS & LABELS	5
2.0 SAFETY GUIDANCE	6
2.1 GENERAL SAFETY	6
2.2 INSTALLATION SAFETY	7
2.3 ELECTRICAL SAFETY	7
2.4 FIRE SAFETY	7
2.5 MAINTENANCE SAFETY	9
3.0 APPLIANCE INFORMATION	12
4.0 OPERATION	13
4.1 COMPONENT PARTS	14
4.1 COMPONENT PARTS – E161i & E163i	14
4.1 COMPONENT PARTS – E143i	15
4.2 CONTROLS – E161i & E163i	16
4.2 CONTROLS – E143i	17
4.3 USING THE APPLIANCE	18
4.4 HOB SETTINGS	19
4.5 POWER BOOST	19
4.6 AUTOMATIC HEAT-UP CONTROL	19
4.7 CONTROL LOCK FUNCTION	19
4.8 PAN DETECTION	20
4.9 RESIDUAL HEAT DISPLAY	20
4.10 DIGITAL DISPLAY CODES	20
4.11 E143i, E161i & E163i – USING THE OVEN	20
5.0 CLEANING AND MAINTENANCE	21
5.1 CLEANING	22
5.2 MAINTENANCE	22
6.0 SPECIFICATION	23
6.1 APPLIANCE WEIGHT TABLE	23
6.2 ELECTRICAL DATA TABLE	23
7.0 DIMENSIONS / CONNECTION LOCATIONS	24/25
8.0 INSTALLATION	26
8.1 SITING / CLEARANCES	27
8.2 ASSEMBLY	28
8.3 ELECTRIC SUPPLY & CONNECTION	29
8.4 COMMISSIONING	32
8.5 INSTRUCTION TO USER	32

9.0 SERVICING	33
9.1 CONTROL PANEL REMOVAL	33
9.2 DOOR REMOVAL	34
9.3 CONTROL SWITCHES REMOVAL	34
9.4 INDUCTION GENERATOR REMOVAL	35
9.5 HOB COOLING THERMOSTAT REMOVAL	37
9.6 REAR COOLING FAN REMOVAL	37
9.7 OVEN THERMOSTAT AND FAN SWITCH	38
9.8 OVEN LIGHT	38
9.9 OVEN ELEMENT REMOVAL	38
9.10 OVEN FAN REMOVAL	38
9.11 SAFETY & OPERATION RELAY REMOVAL	39
9.12 OVEN & REAR COOLING FAN CONTROL FUSES	39
9.13 OVEN SAFETY TRIP SWITCH REPLACEMENT	40
9.14 OVEN SAFETY TRIP SWITCH (FRONT ACCESS)	40
9.15 OVEN LAMP ASSEMBLY REPLACEMENT	41
9.16 CIRCUIT DIAGRAMS	42
9.17 WIRING DIAGRAMS	45
10.0 FAULT FINDING	48
11.0 SPARE PARTS	50
12.0 SERVICE INFORMATION	51

1.0 SYMBOLS



SCREWDRIVER



SPANNER



COOKING OIL



GREASE



WARNING

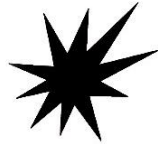

SPARK IGNITION



FLAME



VIEWPORT



ALLEN KEY



IGNITER



C SPANNER



REMOVE DEVICE



PLUG REMOVER



NON-IONISING
ELECTROMAGNETIC
RADIATION



WARNING
ELECTRICITY



READ MANUAL



FIRE RISK

2.0 SAFETY GUIDANCE

2.1 GENERAL SAFETY



- 2.1.1 These instructions are only valid if the country code appears on the appliance. If the code does not appear on the appliance, refer to the technical instructions for adapting the appliance to the conditions for use in that country.
- 2.1.2 These appliances have been UKCA/CE-marked based on compliance with the Gas Appliance Regulations/Product Safety and Metrology Regulations, Electrical and Electromagnetic Compatibility (EMC) Regulations/Directives for the Countries, Gas Types and Pressures as stated on the data plate.
- 2.1.3 This equipment is for professional use only and must be used by qualified persons.



- 2.1.4 Never leave this appliance unsupervised when in use and always turn products off at the end of service.
- 2.1.5 The installer must instruct the responsible person(s) of the correct operation and maintenance of the appliance.



- 2.1.6 Check that no damage has occurred to the appliance or supply cord during transit. If damage has occurred, do not use this appliance.
- 2.1.7 Ensure the supply cord is routed free from the appliance to avoid damage.
- 2.1.8 The appliance has been designed and approved to use Falcon kick plates; non-Falcon kick plates could potentially adversely affect the performance of the appliance by restricting the air to the appliance.
- 2.1.9 Training and Competence: To help ensure the safe use of this appliance there is a requirement for you to provide whatever information, instruction, training and supervision as is necessary to ensure, so far as is reasonably practicable, the health and safety of all users.
- 2.1.10 For further help and information on training and competence we refer you to the Health & Safety Executive website; www.hse.gov.uk document ref: health and safety training INDG345. International customers should default to the health and safety guidelines provided by your government body.
- 2.1.11 Risk Assessment: As part of managing the health and safety of your business you must control any risks identified in your commercial kitchen. To do this you need to think about what might cause harm to people and decide whether you are taking reasonable steps to prevent that harm. This is known as risk assessment. It is important to consider the environment around the product as well as the product itself. For example, oil or food spills will present a significant risk to users so the need to immediately clean up such spills must be reflected in staff training.
- 2.1.12 Record the training that you provide and support it by providing safe system of work (SSOW) documents that set out procedures to be followed for potentially hazardous tasks.
- 2.1.13 For further help and information on risk assessments we would refer you to you the Health and Safety Executive website; www.hse.gov.uk document ref: risk assessment INDG163. International customers should default to the health and safety guidelines provided by your government body.

2.2 INSTALLATION SAFETY



- 2.2.1 Installation must meet national or local regulations. Attention must be paid to safety (installation & use) regulations, health and safety at work act, local and national building regulations, fire precautions act.
- 2.2.2 The installer must instruct the responsible person(s) of the correct operation and maintenance of the appliance.
- 2.2.3 2.2.4 Put a documented system in place for periodic inspections, testing and maintenance of electrical appliances. Check that the fixed electrical installation has been inspected and tested by a competent electrical contractor (e.g. NICEIC-approved or ECA member) as prescribed in BS7671, within the last 5 years.

2.3 ELECTRICAL SAFETY



- 2.3.1 To prevent shocks, this appliance must be earthed.
- 2.3.2 This unit is fitted with an equipotential connection at the rear on the base.
- 2.3.3 Before attempting any maintenance, isolate the appliance at the mains switch and take steps to ensure that it is not inadvertently switched on.
- 2.3.4 We recommend, Supplementary electrical protection with the use of a type A residual current device (RCD).
- 2.3.5 We recommend fixed wiring appliances incorporate a locally situated switch disconnector to connect to, which is easily accessible for switching off and safe isolation purposes. The switch disconnector must meet the specification requirements of IEC 60947.

2.4 FIRE SAFETY



Appliances can present various hazards in the catering environment if not correctly used, operated, and maintained. Hazards including fire, burns from hot pans, contact with hot surfaces, fumes from boiling cleaning chemicals, eye injuries from splashes and slips from oil spillages.

Operator Competency and Training

- 2.4.1 Ensure you are trained in the safe and proper use of the appliance and know how to turn it off and switch the power off at the mains.
- 2.4.2 Ensure you are familiar with the kitchen fire safety procedures and the location and proper use of correct fire safety equipment.

Fire Safety Equipment

- 2.4.3 Provide an appropriate BS compliant fire blanket, and an adequate number of fire extinguishers that comply with BS EN 3 (parts 1-6) and carry a BAFE or LPCB approval mark. At least one must be appropriate for use on electrical fires.

Fire Suppression System

- 2.4.4 We recommend kitchen equipment and extraction systems are protected with a fire suppression system. Check your insurance as this may also be a condition of your policy.
- 2.4.5 Protect cooking and extraction equipment (including any associated extraction ductwork and hoods inside the building) by having an extinguishing system installed, in line with (or the equivalent of) LPS 1223. The system should include a local alarm, automatic activation by a detection system and manual activation – located a safe distance away from the cooking equipment, preferably by a fire escape route door.

Operational Safety

- 2.4.6 Do not leave the appliance unattended when powered on or when it is in use.
- 2.4.7 Always switch the appliance off and remove items from the glass-ceran surface when not in use.

Cleaning

- 2.4.8 Ensure appliances are regularly cleaned serviced and maintained by a qualified and competent service provider, and there is access around the appliance to do so.
- 2.4.9 Ensure that the appliance, surrounding work area and extraction system are regularly cleaned, (at least weekly) to avoid the build-up of fats oils and greases that could present a fire risk. A deep clean should be undertaken at least every 6 months by a specialist contractor.

Electrical Isolation Points

- 2.4.10 Ensure any separate electric switches provided for cooking equipment and/or extractor fans are accessible and clearly labelled.

Care and Maintenance of Thermal and Operational Safety Devices

- 2.4.11 The appliance is fitted with a thermal safety device. This will stop oven operation if it becomes overheated due to a fault. This appliance will always fail safe so long as there is no damage to the thermal safety device.

2.5 MAINTENANCE SAFETY

- 2.5.1 Unless otherwise stated, parts which have been protected by the manufacturer must not be adjusted by the installer or end user.
- 2.5.2 Before any maintenance or cleaning is undertaken, isolate appliance from mains power supply at isolator switch.
- 2.5.3 Suitable protective clothing (PPE) must be worn when maintaining or cleaning this appliance.
- 2.5.4 The appliance must be allowed to cool to a safe temperature before maintenance or cleaning is undertaken.
- 2.5.5 The appliance must not be cleaned with a jet of water or be steam cleaned. Do not use acid or halogen-based (e.g. chlorine) descaling liquids, flammable liquids, cleaning aids or cleaning powders.
- 2.5.6 Failure due to lack of proper cleaning is not covered by warranty.

- 2.5.7 Take care when cleaning not to dislodge or damage thermostat sensor mounted on the side of the oven.
- 2.5.8 If the thermostat or capillary are damaged then do not turn the appliance on and contact Falcon or you approved service provider to undertake the necessary repairs.
- 2.5.9 To obtain maximum performance from this unit regular servicing of the appliance should be undertaken to ensure correct operation, it is functioning as intended, and safe to use. We recommend servicing in accordance with SFG20 Maintenance Schedules and as a minimum, after 2,500 hours of use, or annually, whichever comes first and that a maintenance contract be arranged with an appointed service contact. Visits may then be made at agreed intervals to carry out adjustments and repairs.
- 2.5.10 During Servicing of the appliance, where applicable, please ensure the oven door seal is checked. If the integrity of the seal is compromised, it must be replaced.



- **This appliance may be discoloured due to testing.**
- **These instructions are only valid if the country code appears on the appliance. If the code does not appear on the appliance, refer to the technical instructions for adapting the appliance to the conditions for use in that country.**
- **Installation must meet national or local regulations. Attention must be paid to: safety (installation & use) regulations, health and safety at work act, local and national building regulations, fire precautions act.**
- **To prevent shocks, this appliance must be earthed.**
- **This unit is fitted with an equipotential connection at the rear on the base.**
- **This appliance has been UKCA/CE marked based on compliance with the relevant Electrical and Electromagnetic Compatibility (EMC) Regulations/Directives for the voltages stated on the data plate.**
- **This equipment is for professional use only and must be used by qualified persons.**
- **The installer must instruct the responsible person(s) of the correct operation and maintenance of the appliance.**
- **Unless otherwise stated, parts which have been protected by the manufacturer must not be adjusted by the installer.**
- **Check that no damage has occurred to the appliance or supply cord during transit. If damage has occurred, do not use this appliance.**
- **Ensure the supply cord is routed free from the appliance to avoid damage.**
- **The appliance has been designed and approved to use Falcon kick plates; non-Falcon kick plates could potentially adversely affect the performance of the appliance by restricting the air to the appliance.**
- **All apparatus connected to a potable water network and including water drain device has to be provided with an air break before its discharge to the drainage system. Type AA.**

PREVENTATIVE MAINTENANCE CONTRACT

To obtain maximum performance from this unit regular servicing of the appliance should be undertaken to ensure correct operation, it is functioning as intended, and safe to use. We recommend servicing in accordance with SFG20 Maintenance Schedules and as a minimum, after 2,500 hours of use, or annually, whichever comes first and that a maintenance contract be arranged with an appointed service contact. Visits may then be made at agreed intervals to carry out adjustments and repairs.

Training and competence

To help ensure the safe use of this appliance there is a requirement for you to provide whatever information, instruction, training, and supervision as is necessary to ensure, so far as is reasonably practicable, the health and safety of all users.

For further help and information on training and competence we would refer you the Health and Safety Executive website; www.hse.gov.uk document ref: health and safety training INDG345. International customers should default to the health and safety guidelines provided by your government body.



Risk assessment

As part of managing the health and safety of your business you must control any risks identified in your commercial kitchen. To do this you need to think about what might cause harm to people and decide whether you are taking reasonable steps to prevent that harm. This is known as risk assessment. It is important to consider the environment around the product as well as the product itself. For example, oil or food spills will present a significant risk so users so the need to immediately clean up such spills must be reflected in staff training.

For further help and information on risk assessments we would refer you to you the Health and Safety Executive website; www.hse.gov.uk document ref: risk assessment INDG163. International customers should default to the health and safety guidelines provided by your government body.

3.0 APPLIANCE INFORMATION

These appliances have been UKCA/CE-marked based on compliance with the Gas Appliance Regulations/Product Safety and Metrology Regulations, Electrical and Electromagnetic Compatibility (EMC) Regulations/Directives for the Countries, Gas Types and Pressures as stated on the data plate.

Falcon Foodservice Equipment  P.I.N. STD. EN 

A Ser No. **B** MODEL **C** TYPE I.P.

	AT, CH, CY, CZ, DK, EE, FI, GR, IT, LT, NO, RO, SE, SI, SK	BE, CH, CY, CZ, ES, FR, GB, GR, IE, IT, LT, PT, SI, SK	DE, PL, RO	AT, BE, CH, CY, CZ, DE, DK, EE, FR, GB, GR, HU, IT, LT, NL, PL, RO, SE, SI, SK	CH, CY, CZ, ES, GB, GR, IE, IT, LT, PT, SI, SK	DE, PL, RO	AT, CH, CY, CZ, DK, EE, ES, FI, FR, GB, GR, IE, IT, LT, LV, NL, NO, PT, RO, SE, SI, SK	BE, CY, ES, FI, FR, GB, GR, IE, PT	BE, CH, CZ, ES, FR, GB, GR, IE, IT, LT, NL, PL, PT, SI, SK	
D Cat.	I12H3B/P	I3+	I12E3B/P	I3B/P	I12H3+	I2E	I2H	I3B	I3P	
E p mbar	20;30;50	28-30/37	20;30;50	30;50	20;28-30/37	20	20	28-30	37	
F GAS TYPE	G20	G30	G31							
G GAS RATE	m3/h	kg/h	kg/h							
H Σ Qn	KW	KW	kW							
I EL.									Hz	
J Σ kW			kW	K 						kHz
L	L1	A	L2	A	L3	A				

- A - Serial No
- B - Model No
- C - Flue Type
- D - Gas Category
- E - Gas Pressure
- F - Gas Type
- G - Gas Rate
- H - Total Heat Input
- I - Electrical Rating
- J - Total Electrical Power
- K - Magnetic Field Frequency
- L - Electrical Phase Loading

4.0 OPERATION



IF GLASS-CERAMIC TOP IS CRACKED OR BROKEN IMMEDIATELY DISCONNECT APPLIANCE FROM POWER SUPPLY AND CONTACT YOUR SERVICE AGENT.

THE AIR INTAKE FILTER MUST BE IN POSITION DURING OPERATION IT SHOULD BE CLEANED REGULARLY AND DO NOT OBSTRUCT AIR FILTER ENTRY BELOW.



USERS MUST BE MADE AWARE THAT INDIVIDUALS FITTED WITH A PACEMAKER SHOULD CONSULT THEIR DOCTOR IF IN A CLOSE PROXIMITY TO THIS UNIT. THIS INDUCTION UNIT EMANATES AN 19 kHz TO 35 kHz OUTPUT THAT MAY AFFECT OLDER TYPES OF PACEMAKERS.

USE OF THE CORRECT TYPE OF PAN IS ESSENTIAL FOR CORRECT OPERATION.

DO NOT PLACE ANY METAL OBJECTS, SUCH AS KITCHEN UTENSILS, CUTLERY, ALUMINIUM FOIL, OR PLASTIC VESSELS, ON THE GLASS CERAMIC TOP.

THE USER MUST ALSO BE AWARE OF POTENTIAL TO HEAT JEWELLERY AND DISRUPT ELECTRONIC EQUIPMENT PLACED OVER THE INDUCTION ZONES MAGNETIC FIELD.

DO NOT PLACE CREDIT CARDS, ETC, ON THE GLASS-CERAMIC TOP AS DATA COULD BE WIPED OFF.

NEVER LEAVE THE INDUCTION HOB UNSUPERVISED WHEN IN USE. THE GLASS-CERAMIC TOP MUST NOT BE USED FOR STORAGE.

DAMAGED PANS CAN REDUCE APPLIANCE EFFICIENCY.

4.1 COMPONENT PARTS – E161i & E163i

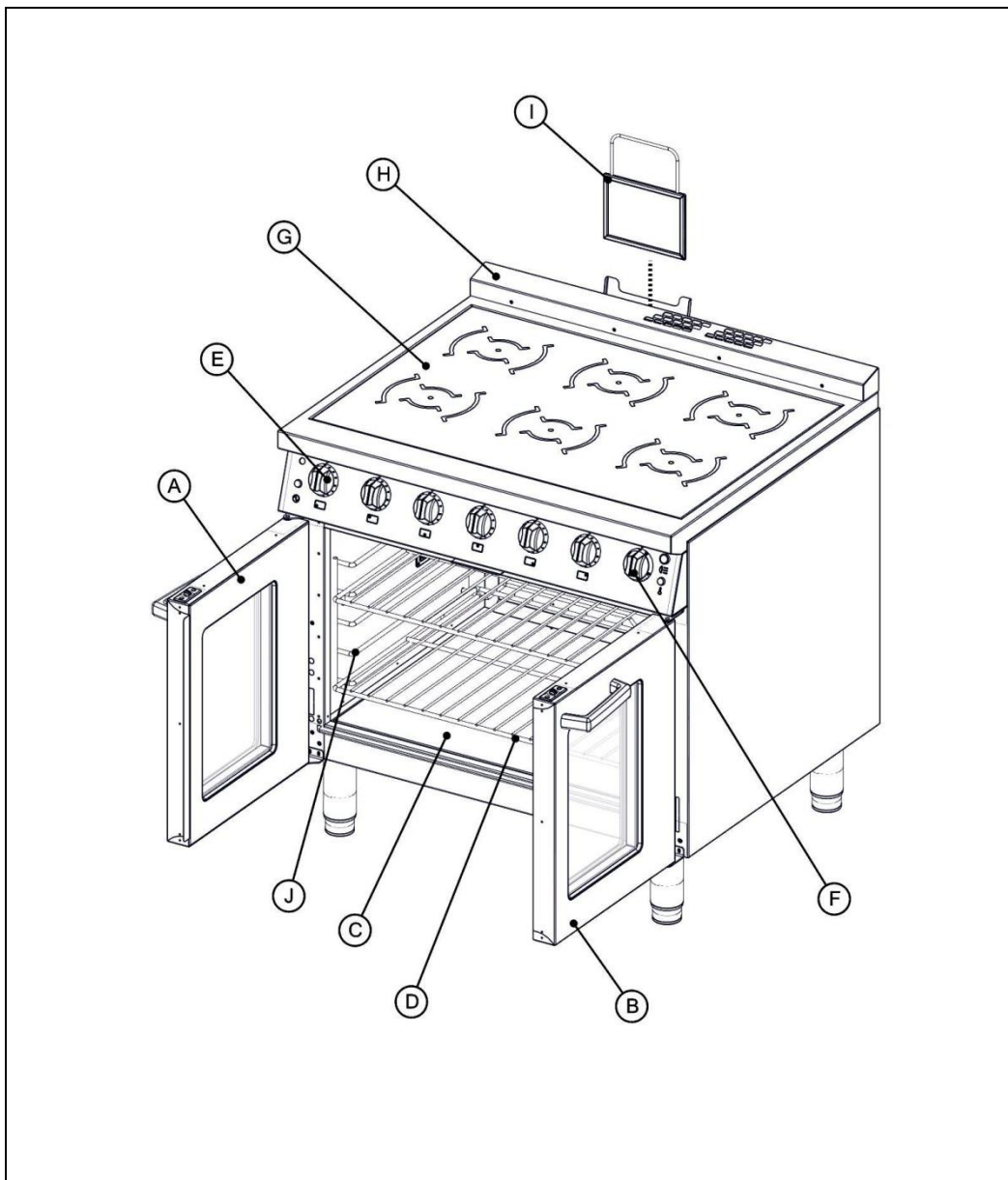

- A - Left hand door
- B - Right hand door
- C - Drip tray
- D - Shelf
- E - Hob zone control

- F - Oven temperature control
- G - Glass
- H - Rear up stand
- I - Filter
- J - Oven shelf hanger

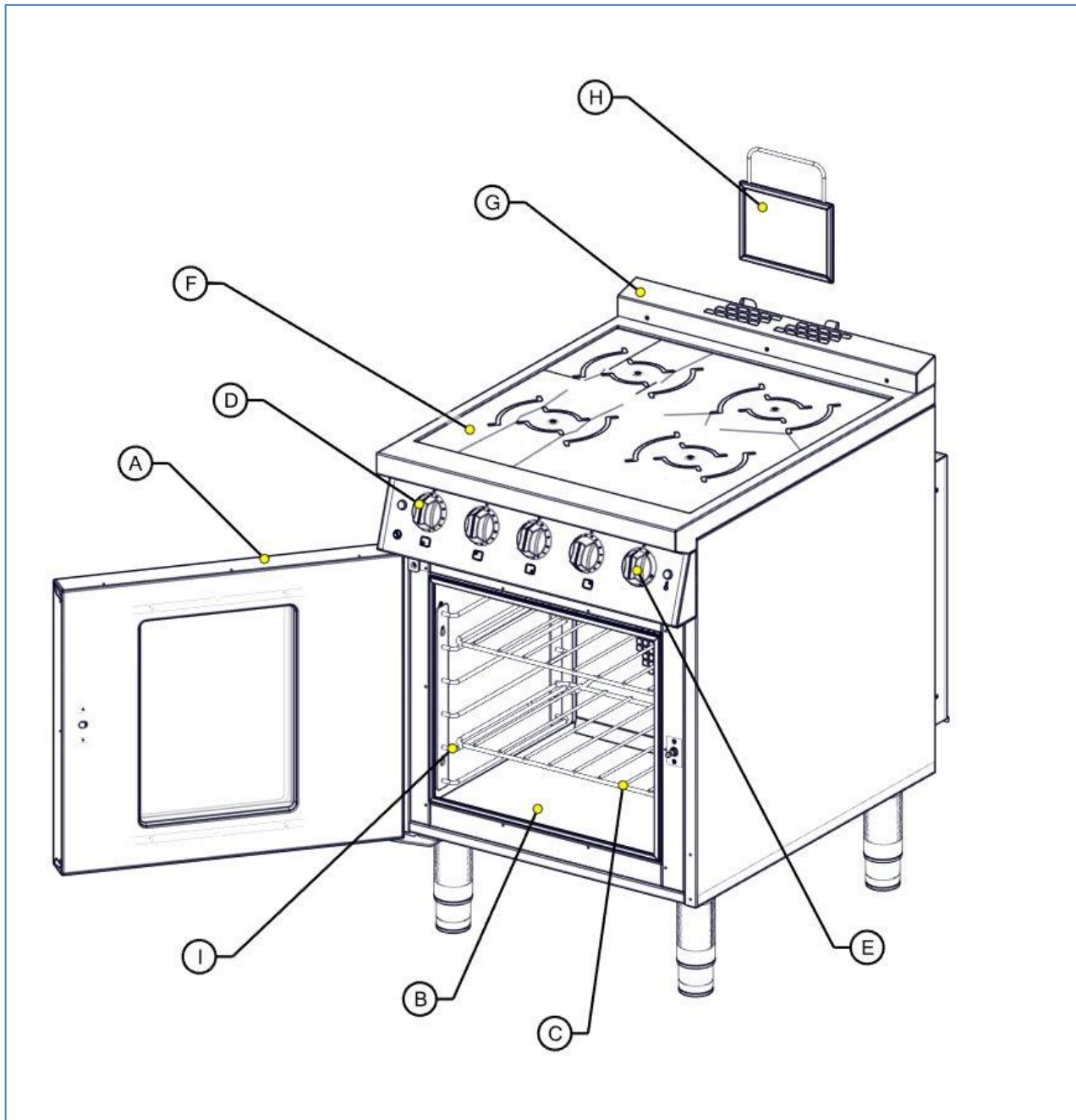

A - Door

B - Drip Tray

C - Shelf

D - Hob zone control

E - Oven temperature control

F - Glass

G - Rear upstand

H - Filter

I - Oven shelf hanger

4.2 CONTROLS – E161i & E163i

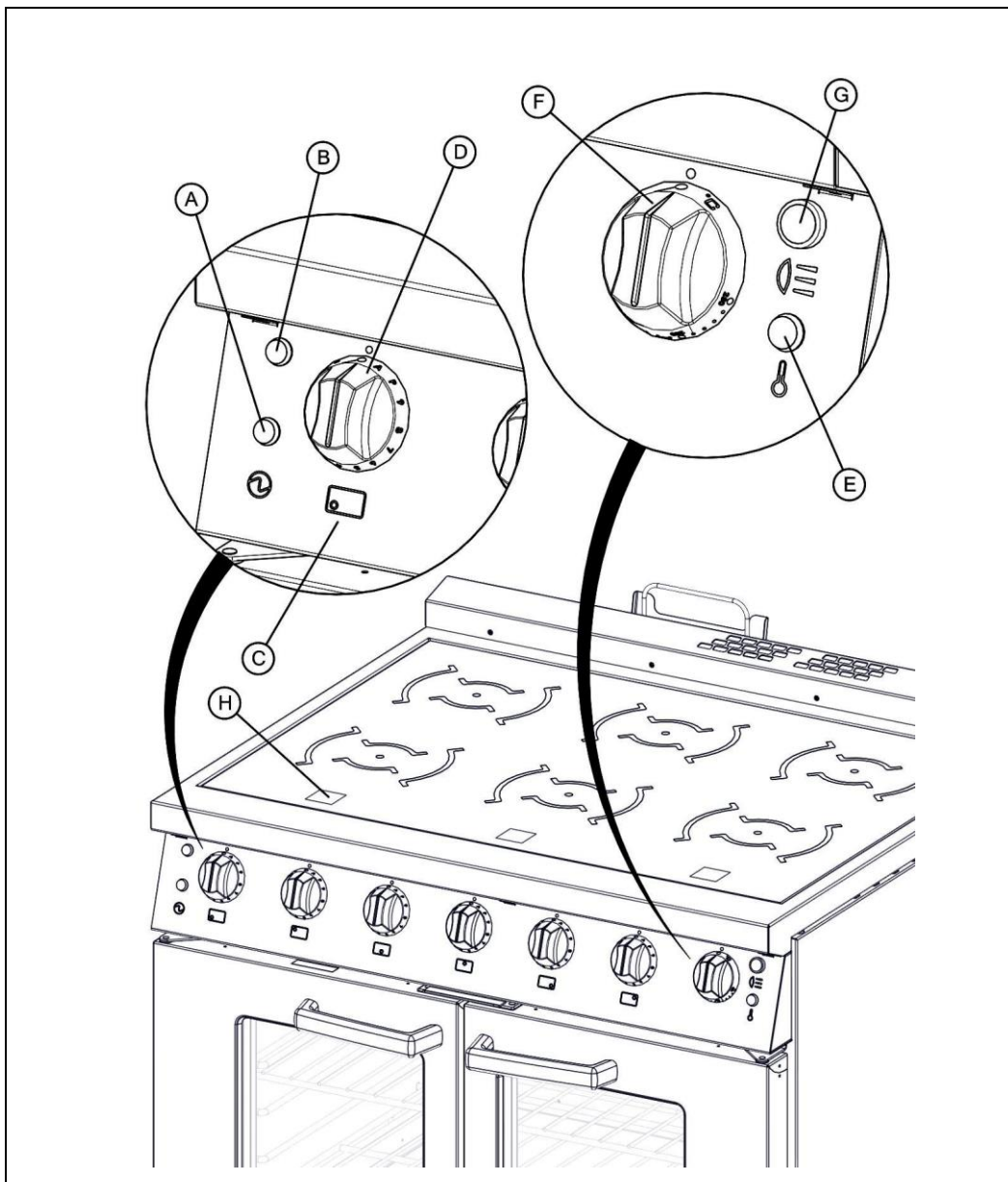

- A - Circuit 1 power neon (red)
- B - Circuit 2 power neon (red) Only on E161i model
- C - Induction zone Indicator
- D - Induction control
- E - Oven heat neon (amber)
- F - Oven temperature control
- G - Oven light switch
- H - Induction zone digital display

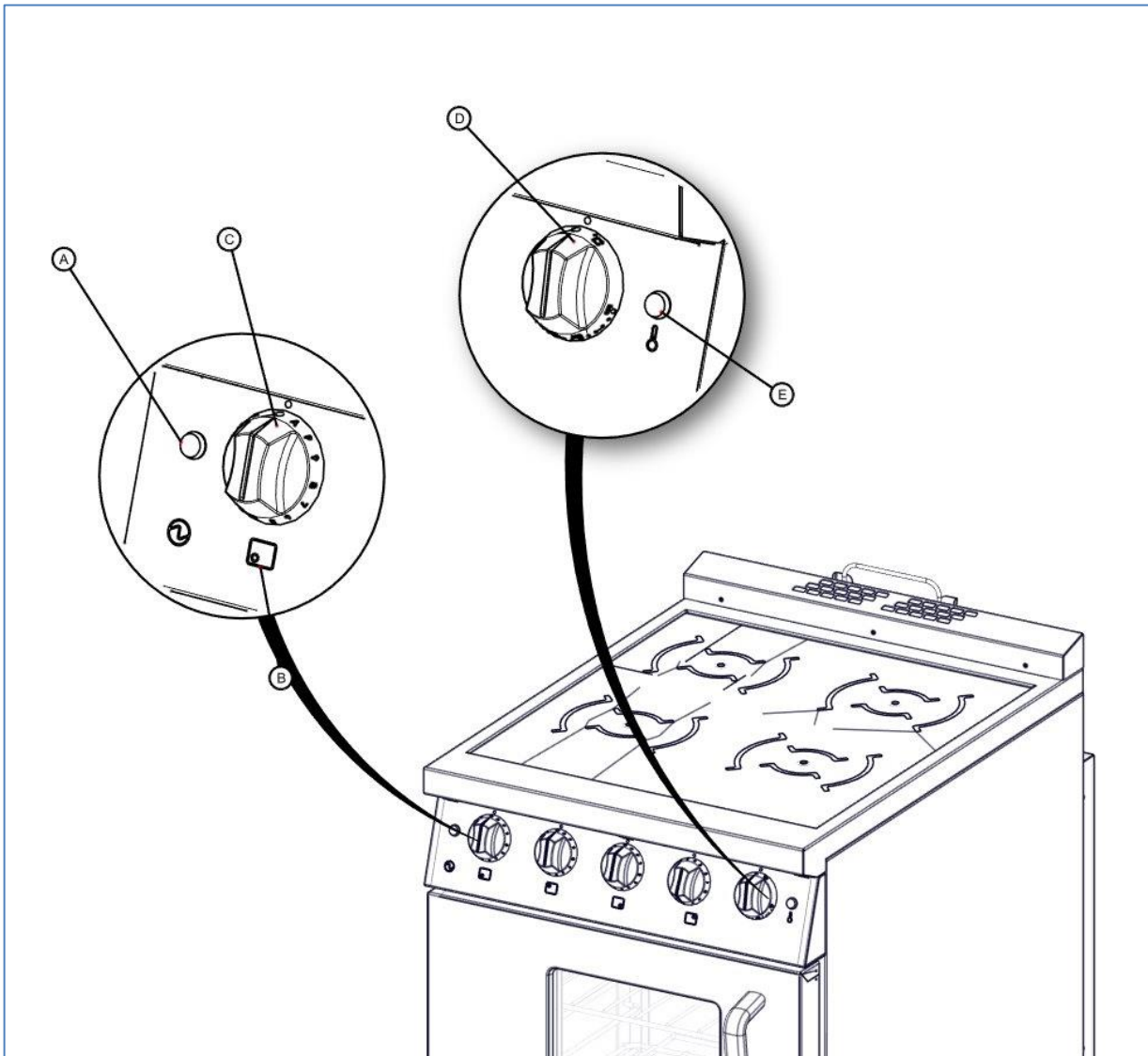

Circuit 1 power neon (red)

- A -
- B - Induction zone indicator
- C - Induction control
- D - Oven temperature control
- E - Oven heat neon (amber)

4.3 USING THE APPLIANCE

4.3.1 Ensure you use the correct size of pan.

<Ø120

Ø120 – Ø250

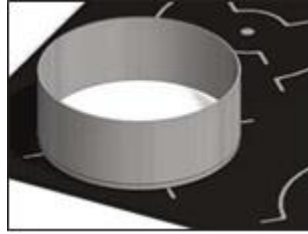
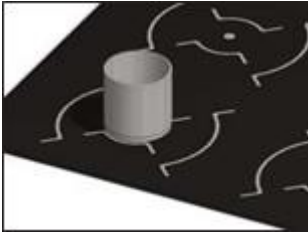

4.3.2 Ensure the pans are central in the cooking zone.

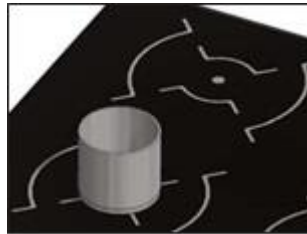
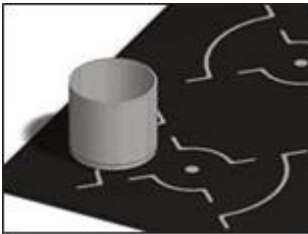

4.3.3 Ensure you use the correct type of pan .

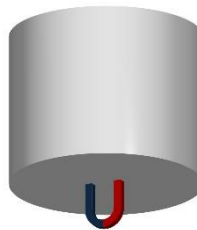
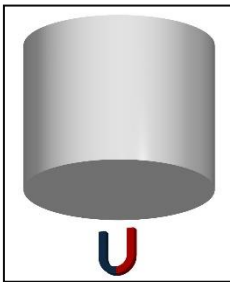

*

4.3.4 Ensure you use a clean flat bottom pan.



4.4 HOB SETTINGS 1-9

4.4.1 Each cooking zone is controlled by a marked, variable control from 1 (lowest) to 9 (highest). Turn induction control knob clockwise to switch on and increase power, turn anti-clockwise to decrease power and switch off.

Table below gives guidance on the power for each setting and relevant time limits for each operation.

Power Level	Low temp hold	1	2	3	4	5	6	7	8	*9
Power %	n/a	3%	5%	8%	12%	18%	28%	42%	64%	100%
Time limit (mins)	120	520	402	318	260	212	170	139	113	90

***On Model E161i : Due to power management restrictions setting 9 will not be available on both zones simultaneously. 1 zone will switch to setting 8.**

4.4.2 **Melt function** is indicated by a single bar. This heats the pan to approx. 45 Degrees.

4.4.3 **Keep warm** is indicated by 2 bars. This heats the pan to approx. 70 Degrees.

4.4.4 **Simmer function** is indicated by 3 bars. This heats the pan to approx. to 94 Degrees.

4.5 POWER BOOST

4.5.1 This is activated by turning the control knob clockwise from level 9. Only one zone per front to back pair can be boosted at a time. It may be boosted again if the system internal temperatures are satisfactory. Boost will run for a maximum of 10 minutes.

4.6 AUTOMATIC HEAT UP CONTROL (AHC):

4.6.1 AHC will give a power of setting to the zone for a pre-set time before reducing to a lower power level set by the control.

(1) To activate the control, turn anti clockwise from the "Off" position to "A" and hold for approx 3 seconds.

(2) Whilst the "A" symbol is illuminated on the glass turn the control knob clockwise to the required setting (1-8).

(3) The display reverts to the "A" symbol and the hob will run at maximum power for the time shown in the below table before reducing power to the final setting.

Power level setting	1	2	3	4	5	6	7	8
Pre-set time (secs)	40	72	120	176	256	432	120	192

4.7 CONTROL LOCK FUNCTION

4.7.1 This function prevents unwanted operation of the hob. When the control lock is active the "L" symbol is shown. It operates in pairs of controls (Left, centre and right). It is activated by turning control knobs anti-clockwise to control lock position and held for approximately 5 seconds. Repeat the same process to unlock.

4.8 PAN DETECTION









4.8.1 This prevents the zone becoming energised until a suitable pan is placed on the zone. Removing a pan will temporarily de-energise the zone, but the zone will remain active. Always switch zone(s) off when not in use. Do not use pan-detection as a substitute on/off switch.

If the pan is made from unsuitable material for induction equipment, the “no pan present”  symbol will be displayed.

4.9 RESIDUAL HEAT DISPLAY

4.9.1 When the temperature of the hob exceeds 60 Degrees the “H” symbol will appear, indicating a hot surface. When shown the induction generator will engage its cooling fans. Do not switch off the appliance and allow cooling to occur. When “H” Symbol disappears either continue operation or switch off.

4.10 DIGITAL DISPLAY CODES

	Melt, Keep warm and simmer functions.
	Power level settings (1-9)
	Power boost function.
	Automatic heat up control.
	Controls lock function.
	Pan detection (no pan present).
	Residual heat display.
	Error codes for generator.
	Error rotary control (lightning symbol).

4.11 E143i, E161i & E163i - USING THE OVEN

4.11.1 To use oven, turn temperature control knob clockwise to desired temperature Ensure heat demand (amber) light illuminates.

4.11.2 When oven has reached temperature, the heat demand (amber) light will extinguish. The light will then illuminate and extinguish at regular intervals as the oven cycles.

4.11.3 Always switch the oven off when not in use.

5.0 CLEANING AND MAINTENANCE

When removing heavy items to aid cleaning or maintenance particular care should be taken. A manual handling risk assessment is the best way to determine the level of risk to anyone using or maintaining this equipment. To help with such an evaluation we have included the weights of individual components that may present significant risk.

For further help and information on manual handling and associated risk assessment we would refer you to you the Health and Safety Executive website; www.hse.gov.uk document ref: manual handling at work INDG143. International customers should default to the health and safety guidelines provided by your government body.

The cleaning of fryers or other products that use hot oil present significant risks to end users and particular care should be taken. Cold water and hot oil for example are an explosive mix and should be avoided at all costs.

Other useful references for health and safety issues:

- www.hse.gov.uk
- Essentials of health and safety at work ISBN978
- Noise at work INDG362
- Safe systems of work
- Other notes added to the body of the instructions



BEFORE ANY CLEANING IS UNDERTAKEN,

ISOLATE THE APPLIANCE FROM MAINS POWER SUPPLY AT ISOLATOR SWITCH.

E161i MODEL HAS TWO POWER SUPPLIES. ENSURE BOTH SUPPLIES HAVE BEEN ISOLATED.

SUITABLE PROTECTIVE CLOTHING MUST BE WORN WHEN CLEANING THIS APPLIANCE.

THE APPLIANCE MUST NOT BE STEAM CLEANED. DO NOT USE ACID OR HALOGEN-BASED (E.G. CHLORINE) DESCALING LIQUIDS, FLAMMABLE LIQUIDS, CLEANING AIDS OR CLEANING POWDERS.

FAILURE DUE TO LACK OF PROPER CLEANING IS NOT COVERED BY WARRANTY.

NOTE: All surfaces are easier to clean if spillages are removed before becoming burnt on, and the appliance is cleaned daily.

It should be noted that certain scouring pads including nylon types can easily mark stainless steel. Care should be exercised during cleaning process. When rubbing stainless steel with a cloth, always rub in the direction of the grain.

5.1 CLEANING

5.1.1 Switch off appliance. Allow appliance to cool down before cleaning.



CLEAN THE AIR INTAKE FILTER REGULARLY. FAILURE TO CLEAN THE FILTER REGULARLY MAY CAUSE PROBLEMS WHICH WILL NOT BE COVERED BY WARRANTY. THE AIR INTAKE FILTER MUST BE IN-PLACE DURING OPERATION.

DO NOT ATTEMPT TO REPAIR OR REPLACE ANY PART OTHER THAN THE AIR INTAKE FILTER. REFER TO THE ERROR CODE LIST TO DEBUG THE PROBLEM.

E161i, E163i & E143i - The air filter is located at the rear of the unit. It can be removed by sliding upwards from the guide. Clean using hot soapy water and refit after drying.

5.1.2 Clean the Ceran-glass hob with hot soapy water and a soft cloth. DO NOT USE metal scrapers.

5.1.3 Enamelled surfaces within oven chamber approved cleaning agents which bear the Vitreous Enamel Development Centre (VEDC) mark are recommended.

5.1.4 Oven chamber - Wipe enamelled surfaces clean while still warm. Use a soft cloth and hot soapy water. Badly stained removable parts should be soaked in hot water with an approved detergent using nylon or scotch cleaning pads will provide good results.

5.2 MAINTENANCE

5.2.1 E161i & E163i - Oven door catch may need to be occasionally lubricated. Push down on roller and apply high melting point lubricant inside the catch and onto roller itself.

5.2.2 If there are issues with closing of the door, try adjusting the catch Use your hands or an appropriate implement to push down on the roller **1** as shown. Whilst holding it down, turn it right **2** to adjust it down, or left **3** to adjust it up as shown.

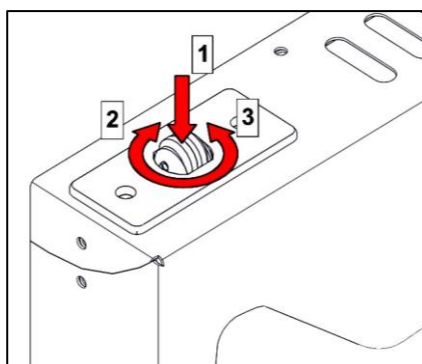

6.0 SPECIFICATION

6.1 APPLIANCE WEIGHT TABLE

APPLIANCE	UNIT WEIGHT (kg)	PACKED WEIGHT (kg)
E161i	116	137
E163i	116	137
E143i	72	82.5

6.2 TECHNICAL DATA TABLE(S)

E161i 1 ph x 2	CURRENT			POWER
PHASE	MIN (A) @ 230V	MAX (A) @ 230V	ACTUAL (A) @ 230V	(kW) @ 230V
L	27.36	31.92	30.4	7
L	23.49	27.41	26.1	6
E163i 3N~	CURRENT			POWER
PHASE	MIN (A) @ 230V	MAX (A) @ 230V	ACTUAL (A) @ 230V	(kW) @ 230V
L1	27	31.5	30	7
L2	27	31.5	30	7
L3	14.49	16.91	16.1	4
E143i 3N~	CURRENT			POWER
PHASE	MIN (A) @ 230V	MAX (A) @ 230V	ACTUAL (A) @ 230V	(kW) @ 230V
L1	12.5	14.6	13.9	3.2
L2	14.4	16.8	16	3.7
L3	14.	16.8	16	3.7



IF ANY CURRENT IS OUT WITH THESE TOLERANCES, THE CAUSE MUST BE INVESTIGATED AND RECTIFIED.

7.0 DIMENSIONS / CONNECTION LOCATIONS

E161i & E163i

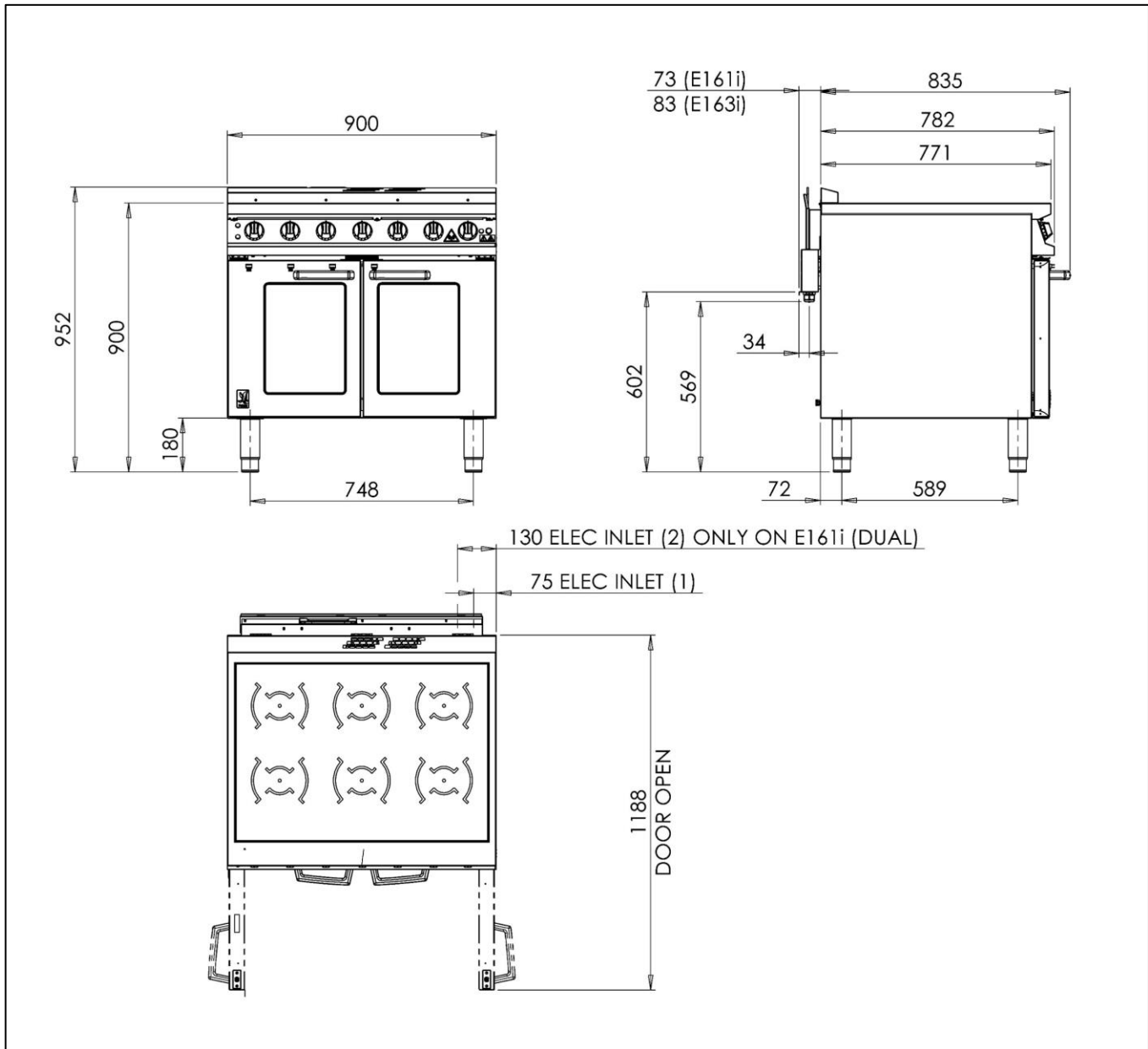

E143i

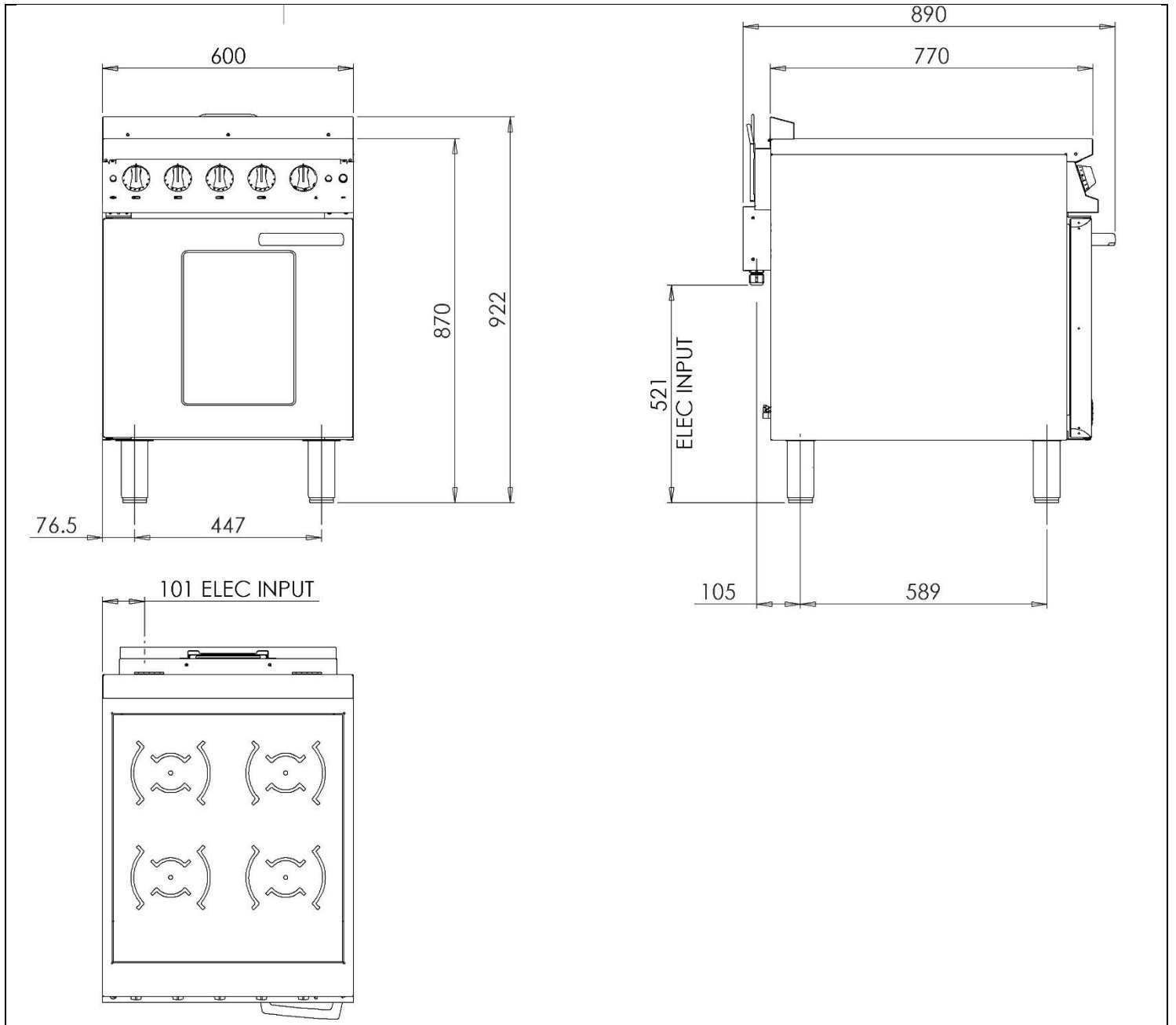

8.0 INSTALLATION

Electrical Safety and Advice Regarding Supplementary Electrical Protection

Commercial kitchens and foodservice areas are environments where electrical appliances may be located close to liquids, or operate in and around damp conditions or where restricted movement for installation and service is evident.

The installation and periodic inspection of the appliance should only be undertaken by a qualified, skilled and competent electrician; and connected to the correct power supply suitable for the load as stipulated by the appliance data label.

The electrical installation and connections should meet the necessary requirements to the local electrical wiring regulations and any electrical safety guidelines.

We recommend: -

- Supplementary electrical protection with the use of a type A residual current device (RCD)
- Fixed wiring appliances incorporate a locally situated switch disconnecter to connect to, which is easily accessible for switching off and safe isolation purposes. The switch disconnecter must meet the specification requirements of IEC 60947.

Your attention is drawn to: -

BS 7671:2018–Guidance Note 8 - 8.13: Other locations of increased risk.

It is recognized that there may be locations of increased risk of electric shock other than those specifically addressed in Part 7 of BS 7671. Examples of such locations could include laundries where there are washing and drying machines in close proximity and water is present, and commercial kitchens with stainless steel units, where once again, water is present.

Where because of the perception of additional risks being likely, the installation designer decides that an installation or location warrants further protective measures, the options available include:

- Automatic Disconnection of Supply (ADS) by means of a residual current device having a residual operating current not exceeding 30mA;
- Supplementary protective equipotential bonding; and
- Reduction of maximum fault clearance time.

The provision of RCDs and supplementary bonding must be specified by the host organization's appointed installation designer or electrical contractor and installed by a suitably qualified and competent electrician so as to comply with Regulations 419.2 and 544.2

8.1 SITING / CLEARANCES

E161i & E163i

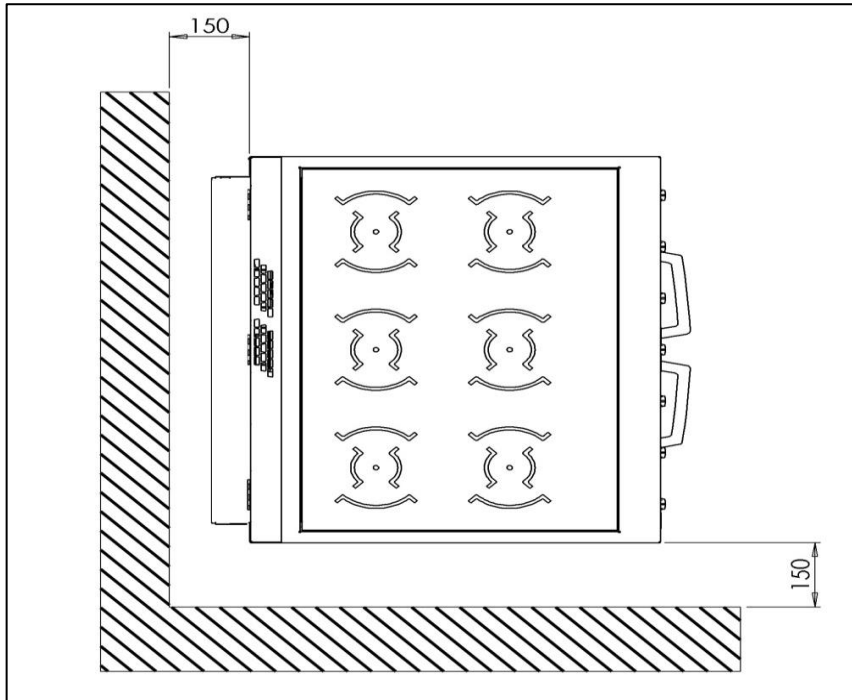

E143i

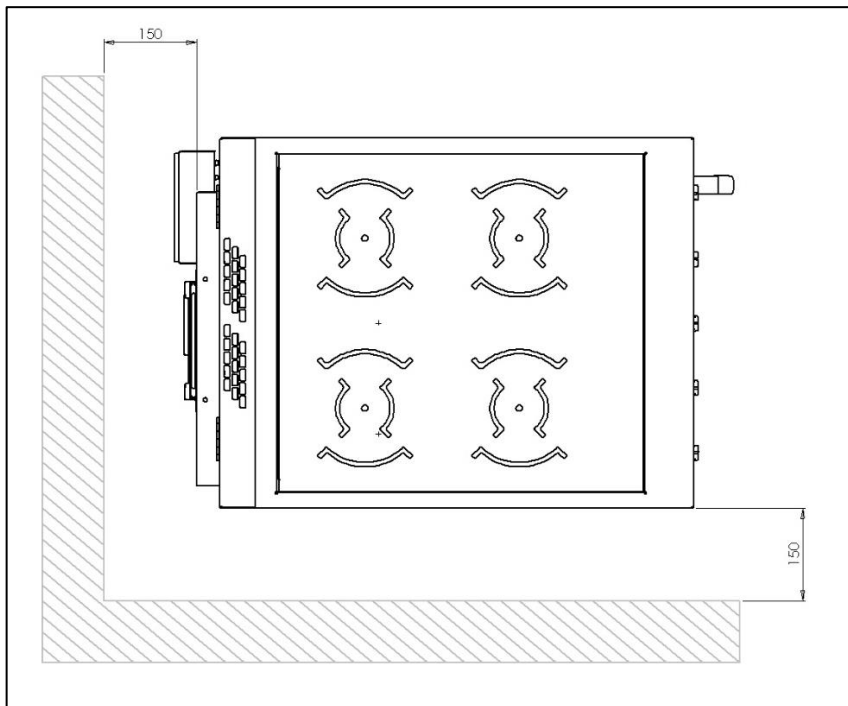

CAUTION: WALLS CLOSER THAN 150mm TO THE APPLIANCE MUST BE NON-COMBUSTIBLE. IF SITING THE NECESSARY CLEARANCES TO ANY COMBUSTIBLE WALL MUST BE THE LARGEST FIGURE GIVEN FOR INDIVIDUAL APPLIANCES INSTRUCTIONS.

8.2 ASSEMBLY

8.2.1 Position the appliance and level using feet adjusters as shown below.

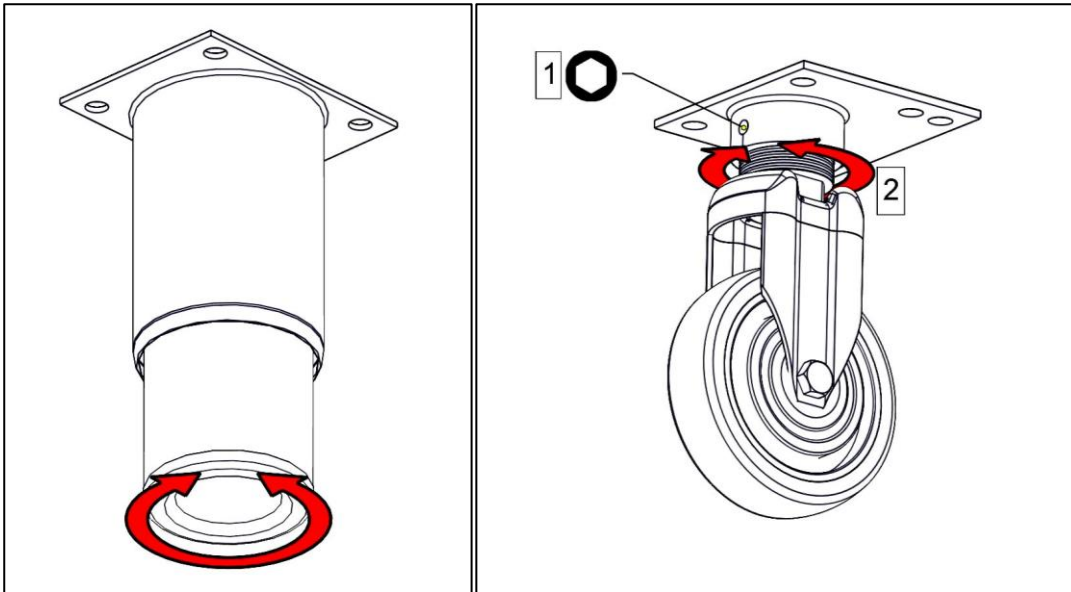

TAKE CARE WHEN MOVING AN APPLIANCE FITTED WITH CASTORS.

8.3 ELECTRIC SUPPLY & CONNECTION

The location of the electrical connection is as seen in section 7.0. this unit is suitable for AC supplies only.

E161i & E163i ACCESS PANEL REMOVAL

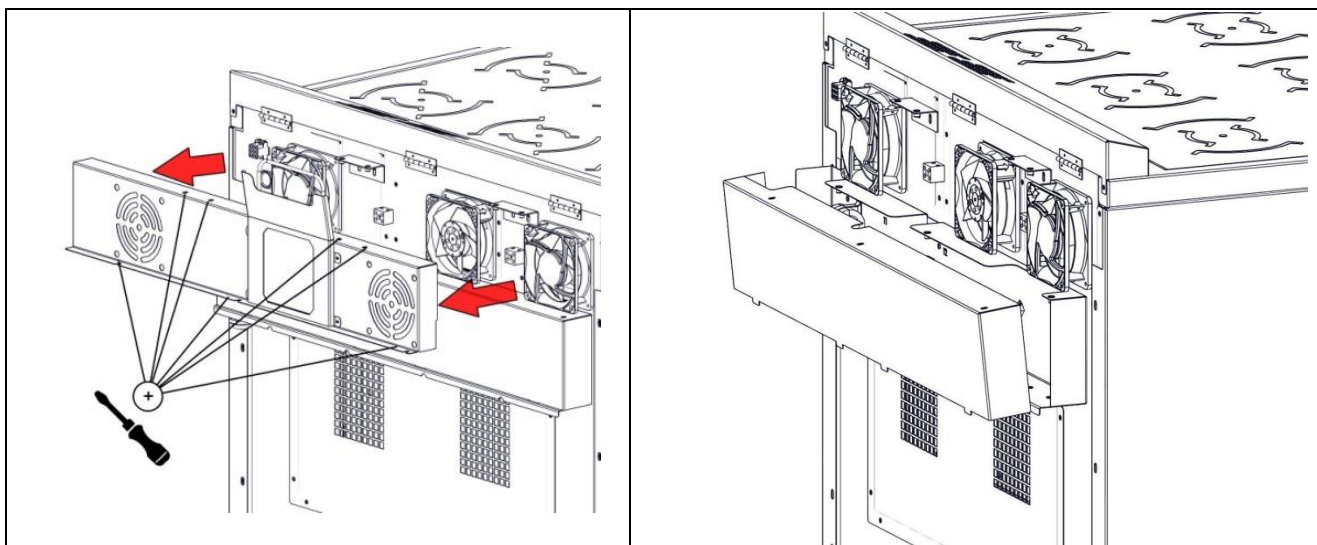

To install the mains cable, remove upper rear fan cover and lower terminal cover panel as shown above and feed the cable through the cable gland(s) and connect the mains supply to the terminal block(s).

E143i ACCESS PANEL REMOVAL

To install the mains cable, remove the rear fan/electrics cover as shown above and feed the cable through the cable gland(s) and connect the mains supply to the terminal block(s).

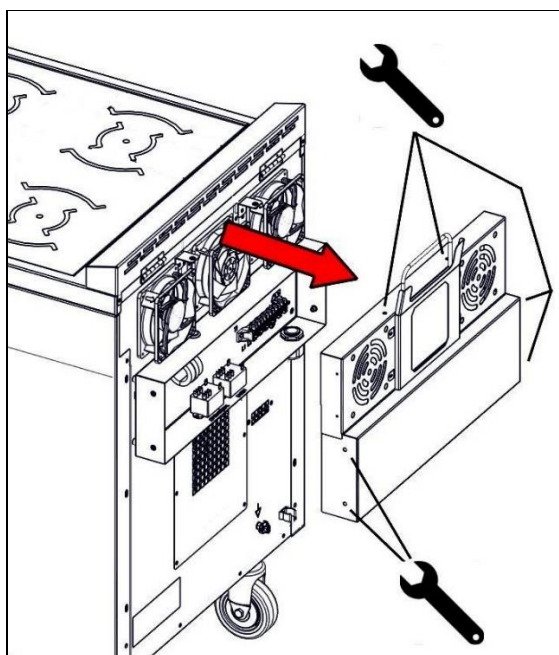



THIS APPLIANCE MUST BE EARTHED

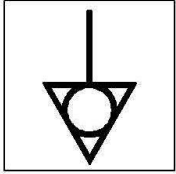

This appliance is also provided with a terminal for connection of an external equipotential conductor. This terminal is an effective electrical contact with all fixed exposed metal parts of the appliance and shall allow the connection of conductor having a nominal cross-section area of up to 10mm². It is located at the rear of the unit and identified by the following label and must only be used for bonding purposes.



MAINS INPUT CONNECTION CABLE IS NOT SUPPLIED; SUITABLE CABLE WILL CONFORM TO CODE DESIGNATION IEC 60245-57.

E163i MODEL (DIN rail mounted terminal block)

The standard terminal arrangement is Three phase (400V 3N~). Refer to image below and wiring diagram in section 9.17.

Install an appropriate three phase mains supply cable with a 32amp plug.

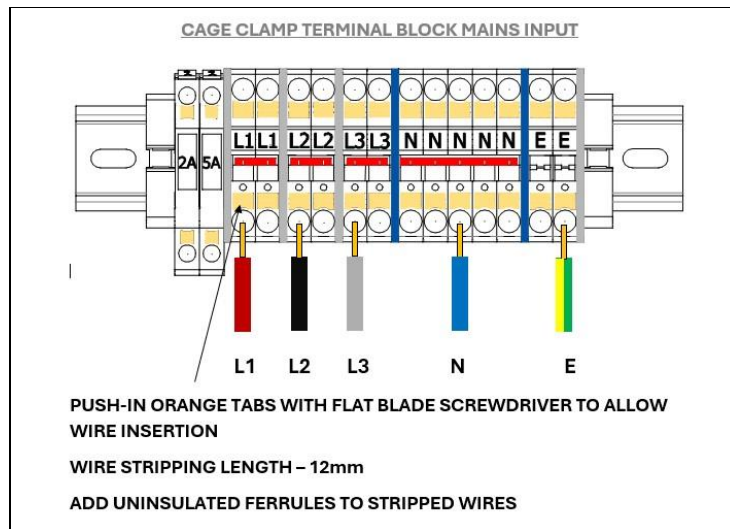

Live 1 (Phase 1)	Brown
Live 2 (Phase 2)	Black
Live 3 (Phase 3)	Grey
Neutral	Blue
Earth	Yellow/Green

E161i MODEL (Twin supply)

On Model **E161i** there is a requirement for two **separate** power supplies.
The standard terminal arrangement is Single phase (2x 230V~).

On this model there are two independent terminal blocks for each **separate** supply. This must be wired as per the circuit diagram.

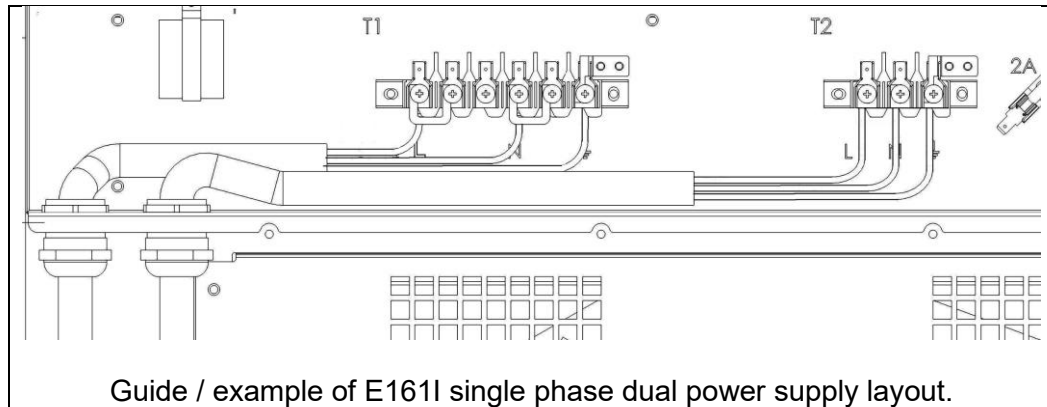

E143i MODEL

On Model **E143i** the standard terminal arrangement is Three phase (400V 3N~). Install an appropriate three phase mains supply cable with a 16-amp plug.

Live 1 (Phase 1)	Brown
Live 2 (Phase 2)	Black
Live 3 (Phase 3)	Grey
Neutral	Blue
Earth	Yellow/Green

8.4 COMMISSIONING

Refer to section 4.0 for operation. If the oven safety thermostat is activated, refer to section 9.13 to reset it.

Carry out the following operation:

- 8.4.1 Turn on mains power supply on.
- 8.4.2 Ensure red neon(s) illuminates.
- 8.4.3 Place a pan suitable for induction cooker tops, filled with water, upon a cooking zone. The pan minimum diameter cannot be less than 120mm.
- 8.4.4 Switch all cooking zones on to position 8.
- 8.4.5 Ensure that corresponding digital display on hob illuminates and remains lit. This indicates that the “Pan detection” feature is working.
- 8.4.6 Repeat on all cooking zones.
- 8.4.7 Leave pots to heat until water boils.
- 8.4.8 Switch controls off.

E143i, E161i & E163i – Oven

- 8.4.9 Turn the oven temperature control knob to 200°C.
- 8.4.10 Ensure amber neon illuminates.
- 8.4.11 Let the oven heat up. When amber neon switches off, check the oven temperature. Ensure the temperature is 200°C +/-10°C.
- 8.4.12 Switch appliance off.

8.5 INSTRUCTION TO USER

- 8.5.1 After installation and commissioning is completed, please hand the user instructions to the user and ensure that the person/s responsible understand the instructions regarding correct operation and cleaning of the appliance.



PLEASE FILL OUT THE INFORMATION TABLE ON THE FRONT COVER AFTER COMMISSIONING

If the appliance does not operate correctly, please refer to section 9.0 to rectify the problem.

9.0 SERVICING



BEFORE ATTEMPTING ANY MAINTENANCE, ISOLATE THE APPLIANCE AT THE MAINS SWITCH AND TAKE STEPS TO ENSURE THAT IT IS NOT INADVERTENTLY SWITCHED ON.



MAINTENANCE CHECK

Regular servicing of the appliance should be undertaken to ensure correct operation, it is functioning as intended, and safe to use. We recommend servicing after 2,500 hours of use, or annually, whichever comes first.

Any maintenance schedule should be carried out in accordance with SFG20 Maintenance Schedules. Should any issues with the integrity of the components be identified these should be replaced. If the appliance is not considered safe the unit should be removed from service and the responsible person advised why the unit is not safe to use and what remedial action is needed. Contents of the maintenance schedule should be agreed with the maintenance provider.

9.1 CONTROL PANEL REMOVAL – E161i & E163i

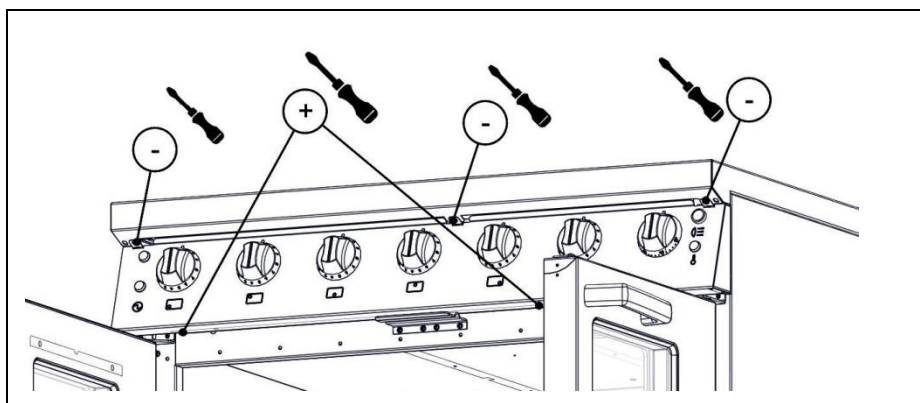

9.1.1 Remove fixings at top and bottom of control panel.

9.1.2 Open oven door and pull control panel forward whilst slightly easing the bottom edge up. Support control panel upon door.

9.1.3 When replacing panel, take care not to trap any connecting wires. Replace shake proof washers below fixings.

CONTROL PANEL REMOVAL - E143i

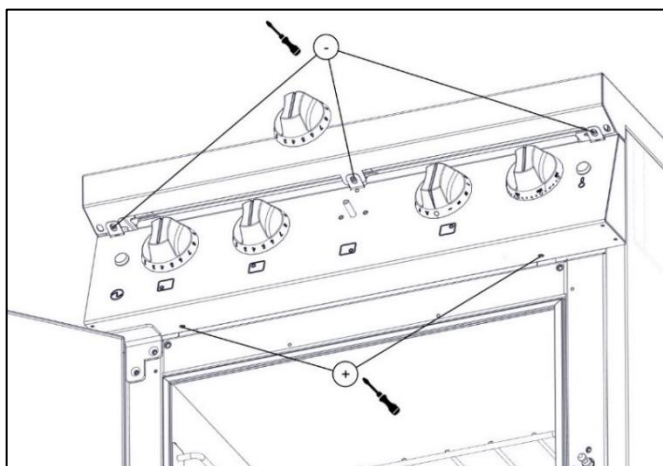

9.2 DOOR REMOVAL

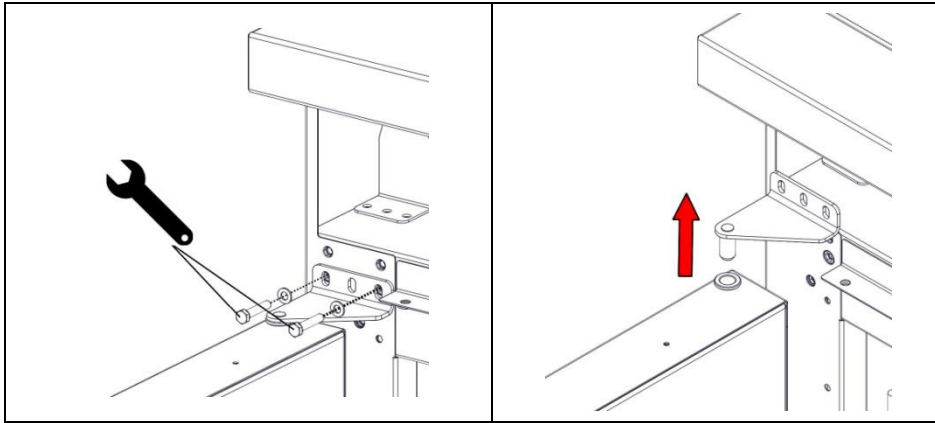

9.2.1 Remove control panel as per section 9.1.

9.2.2 Remove bolts from hinge bracket and then hold door remove bracket and lift door from the appliance.

9.3 CONTROL SWITCHES REMOVAL

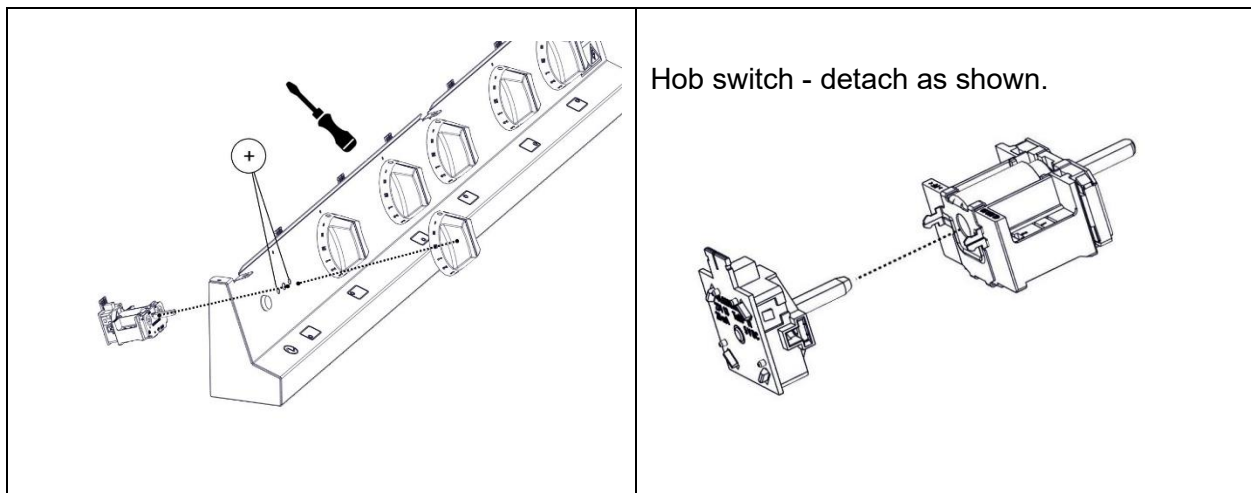

9.3.1 E161i & E163i - Remove control panel as detailed in Section 9.1

9.3.2 E143i – Remove top screws from control panel. Raise hob and support with struts.

9.3.3 Remove switch connections and note wire arrangement. Pull off control knob. Undo fixings to release switch.

9.3.4 Fit replacement switch, ensuring that shake proof washers are fitted under fixing screws.

9.4 INDUCTION GENERATOR REMOVAL – E161i & E163i

9.4.1 Remove control panel as detailed in Section 9.1 but do not take out the bottom screws, unless the control panel must also be removed.

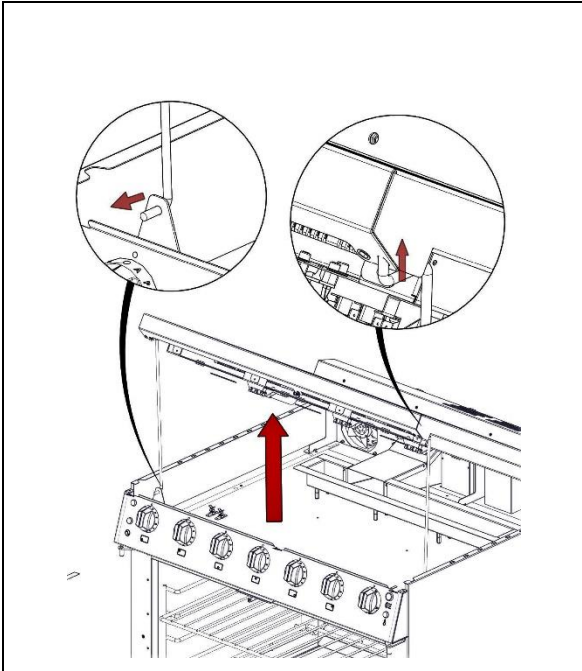

9.4.2 Tilt hob up and lift out hob stay. Fit hob stay into lower mounting bracket and cranked end into slot on hob as shown above. Fit second hob stay on other end. Ensure both are secure before work is carried out.

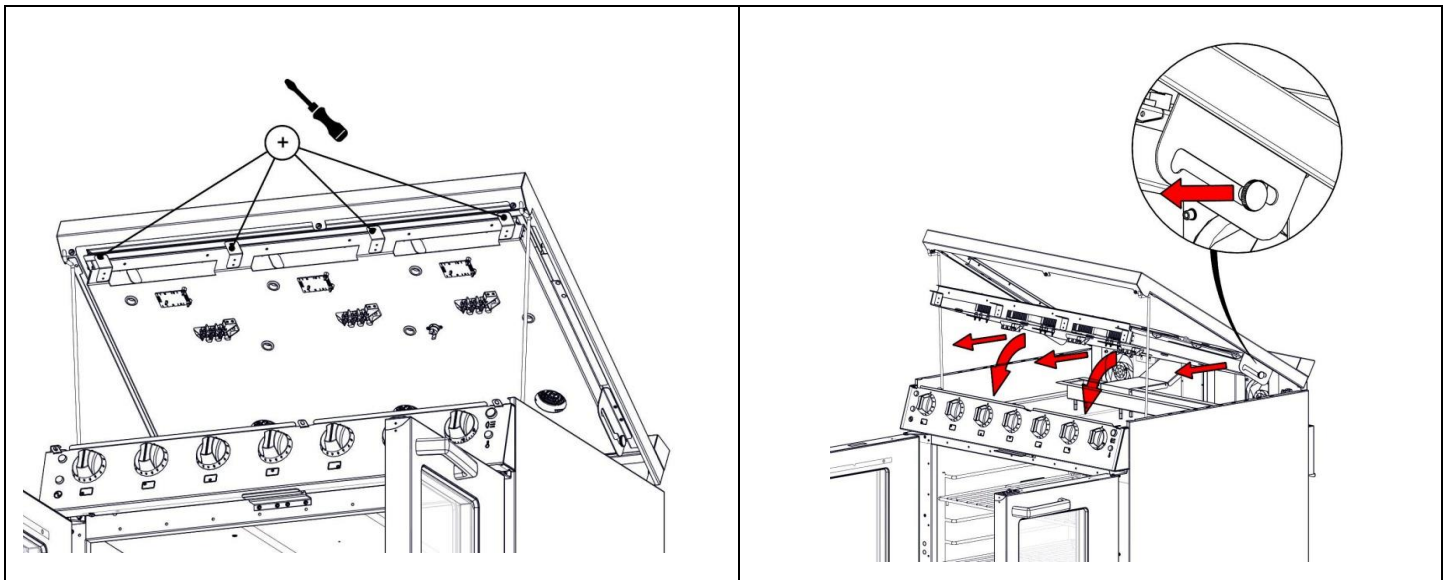

9.4.3 Un-fasten four screws on inner cradle assembly pull cradle forward and tilt down.

9.4.4 Disconnect generator wires from three-way terminal block. Remove wiring, noting connection positions.

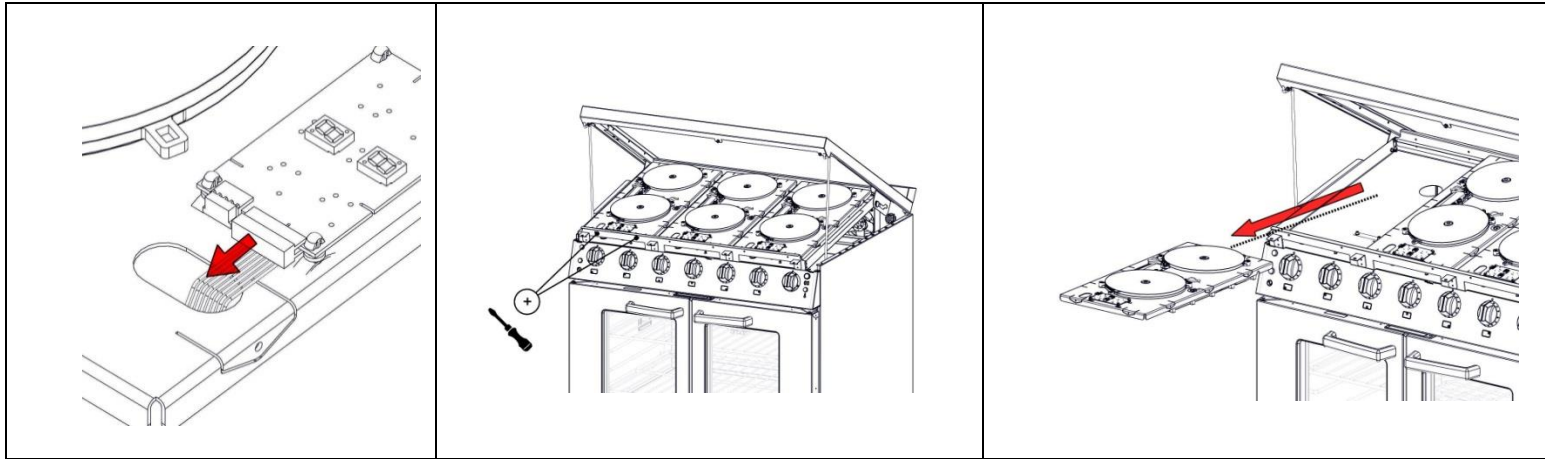

9.4.5 Unplug **8 Pole** ribbon cable from PCB display board. Un-fasten two screws per generator. Whilst removing induction generator from the cradle assembly feed electrical cables out of the cable entry holes.

9.4.6 When re-fitting feed cable back into cable entry holes and position generator into the cradle. Ensure Generator is placed between the stop at the rear of the cradle. Fit two screws and secure the generator in place on the cradle. Reconnect the 8 Pole ribbon cable onto display board.

9.4.7 . Re-Fasten four screws (three on E143i) on inner cradle assembly and ensure electrical connections are restored as per detailed in wiring diagram.

9.4.8 Remove stay and place back into centre fixing position,

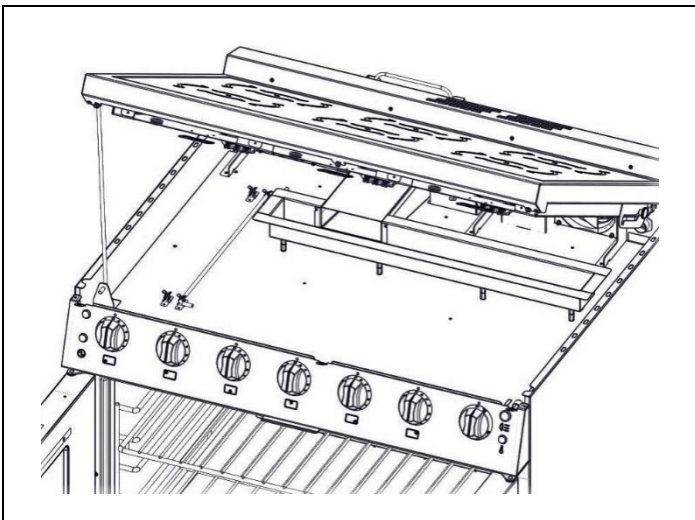

9.4.9 * Remove second stay whilst holding hob and place back into centre fixing position. Gently lower hob down and fix with three fixing screws.

9.5 HOB COOLING THERMOSTAT REMOVAL

9.5.1 The hob chamber temperature is controlled with a thermostat, the thermostat is self-resetting. It is located on the Hob cradle assembly.

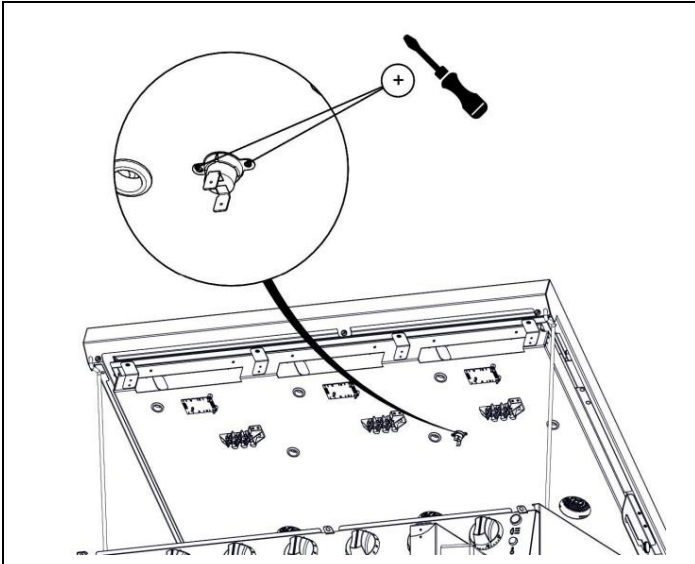

9.5.2 To remove undo two screws on the flanged collar and release.

9.5.3 Electrical connections to be restored as per detailed in wiring diagram.

9.6 REAR COOLING FAN REMOVAL

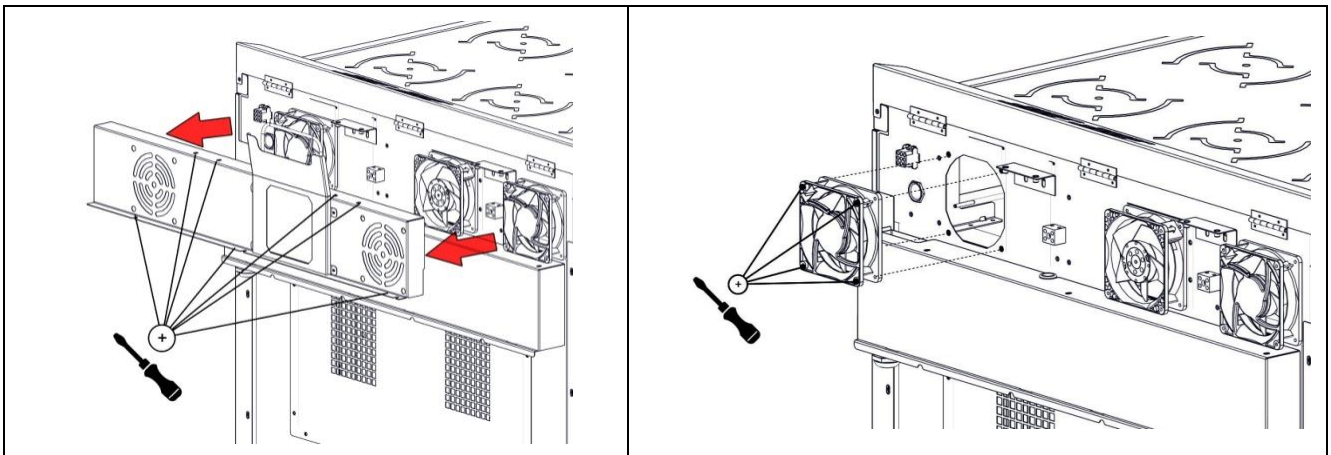

Note: Two outer fans extract the hot air from inside the appliance. Centre Fan Induces clean air into the appliance.

9.7 OVEN THERMOSTAT AND OVEN FAN SWITCH

- 9.7.1 Remove control panel as detailed in Section 9.1.
- 9.7.2 Undo fixings from control panel.
- 9.7.3 Remove wiring, noting connection positions.
- 9.7.4 The combined switch and thermostat may now be removed from front panel. The parts are secured by screw fixings and are supplied together.
- 9.7.5 To remove phial, undo from bracket inside oven and ease back through oven side wall.
- 9.7.6 Replace in reverse order.
- 9.7.7 Electrical connections to be restored as detailed in respective wiring diagram.

9.8 OVEN LIGHT (PUSH BUTTON)

- 9.8.1 Remove control panel as detailed in Section 9.1.
- 9.8.2 Disconnect wires from switch.
- 9.8.3 Undo retaining nut and withdraw switch.
- 9.8.4 Replace in reverse order.

9.9 OVEN ELEMENTS REMOVAL

- 9.9.1 Remove shelves and back baffle. Undo element fixing screw and withdraw into oven.

9.10 OVEN FAN REMOVAL

- 9.10.1 Remove oven shelves, back baffle and fan impellor (Note – The nut is LH thread).
- 9.10.2 Remove fan support plate and tilt forward into oven.
- 9.10.3 Undo fan support plate fixings and electrical connections.
- 9.10.4 Fan may now be removed. Replace in reverse order.
- 9.10.5 Electrical connections to be restored as detailed in wiring diagram.

9.11 SAFETY AND OPERATION RELAY REMOVAL

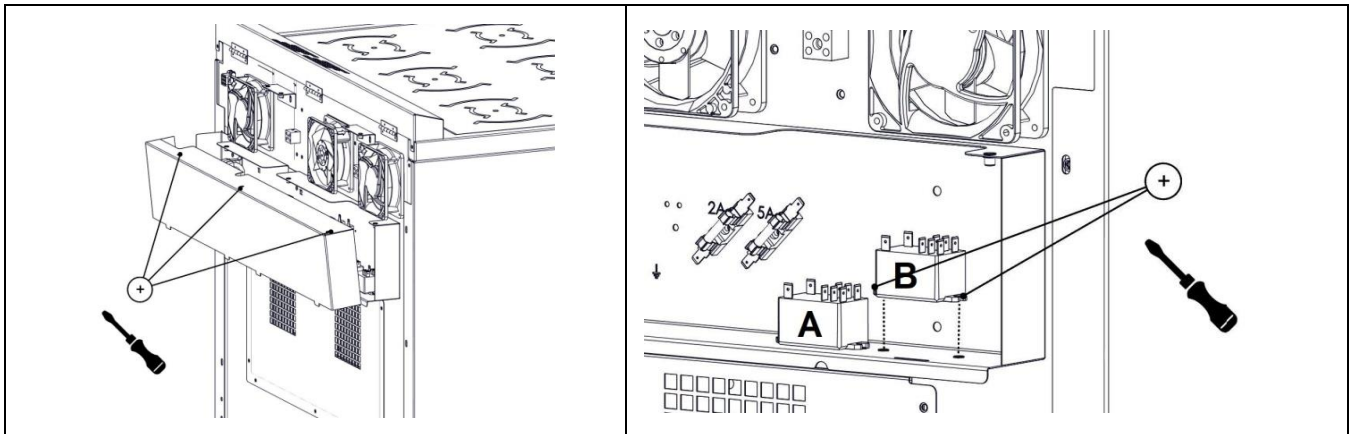

9.11.1 Remove cover plate from outer back panel.

9.11.2 Undo electrical connections from relay and remove fixings.

9.11.3 Replace in reverse order. Electrical connections to be restored as detailed in wiring diagram.

9.11.4 Unit is fitted with two relays: "A" is the operating relay and "B" is the safety relay.

9.12 OVEN AND REAR COOLING FAN CONTROL FUSES

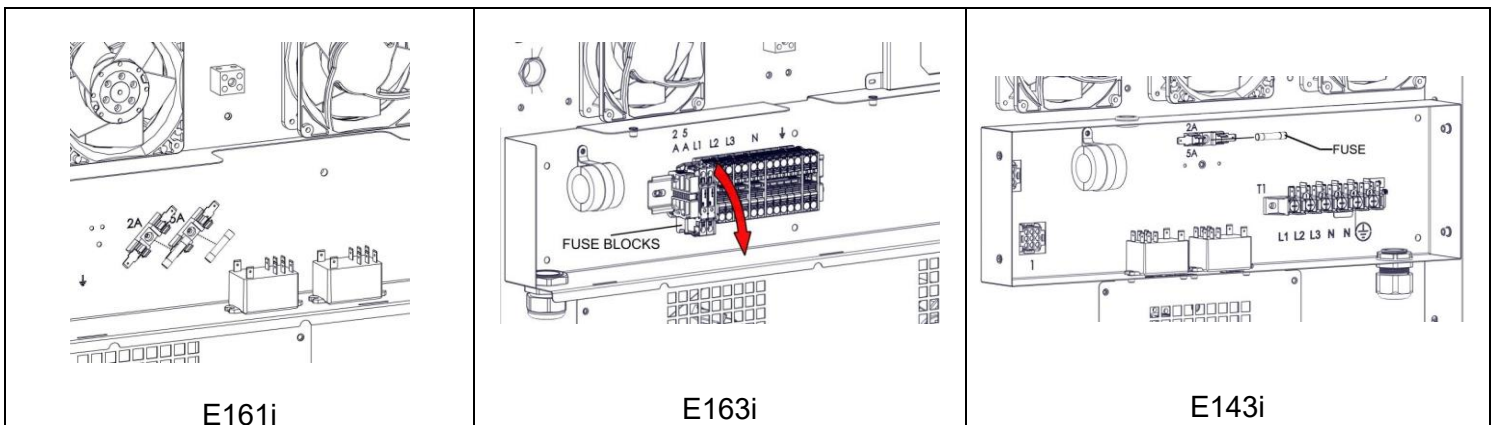
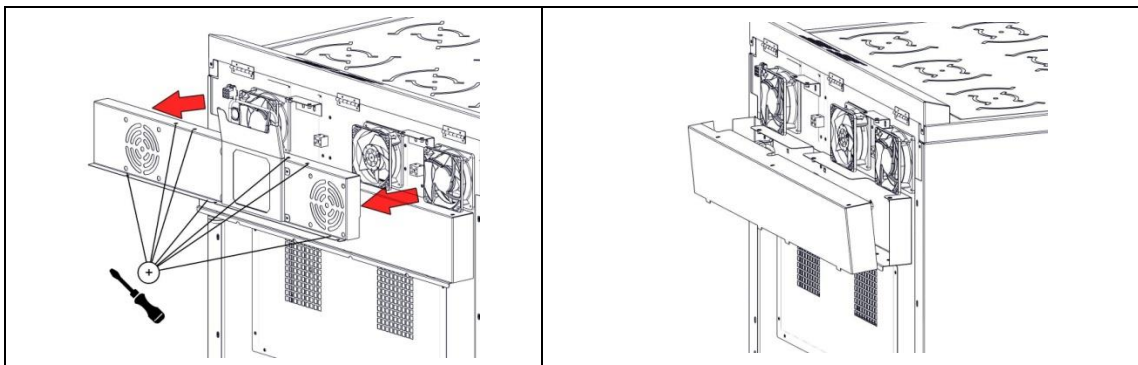

9.13 OVEN SAFETY TRIP SWITCH REPLACEMENT

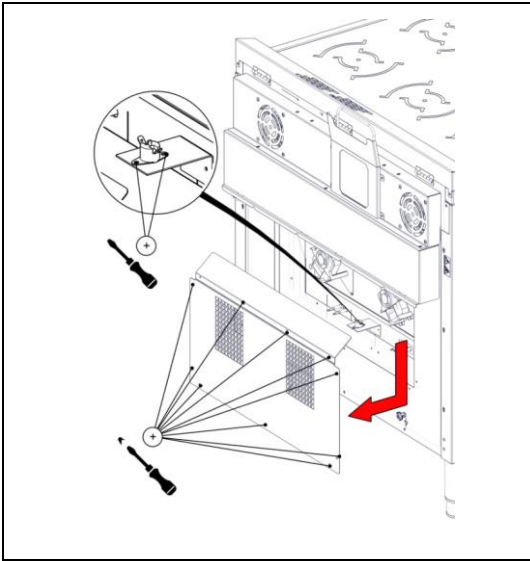

9.13.1 An overheat safety trip is fitted to the oven chamber back panel. Accesses through the outer back panel cover plate (see warning note below).



Warning If safety trip has been activated, reason for overheating must be identified before returning the appliance to service.

9.13.2 To reset, press button.

9.13.3 If the switch is faulty remove by undoing two fixing screws on mounting plate.

9.13.4 Apply heat sink paste to underside of thermostat plate and re-attach new thermostat to mounting plate.

9.13.5 Electrical connections to be restored as per detailed in wiring diagram.

9.14 OVEN SAFETY TRIP SWITCH REPLACEMENT (FRONT ACCESS)

9.14.1 In any condition where space is restricted at appliance rear, the overheat safety trip may be accessed through the oven compartment by removal of pan support panel.

9.14.2 Undo top and bottom fixings of fan baffle and tilt baffle forward to remove.

9.14.3 Take care not to strain the electrical wiring.

9.15 OVEN LAMP ASSEMBLY REPLACEMENT

9.15.1 Remove control panel as detailed in Section 9.1

9.15.2 Remove right or left-hand door (as required) by undoing door hinge fixings. Support door during this process.

9.15.3 Remove fixings from side panel front.

9.15.4 Remove fixings from side panel rear.

9.15.5 Disconnect electrical connections.

9.15.6 Remove lamp assembly

9.15.7 Replace in reverse order.

9.16 CIRCUIT DIAGRAMS

9.16.1 E161i Circuit diagram

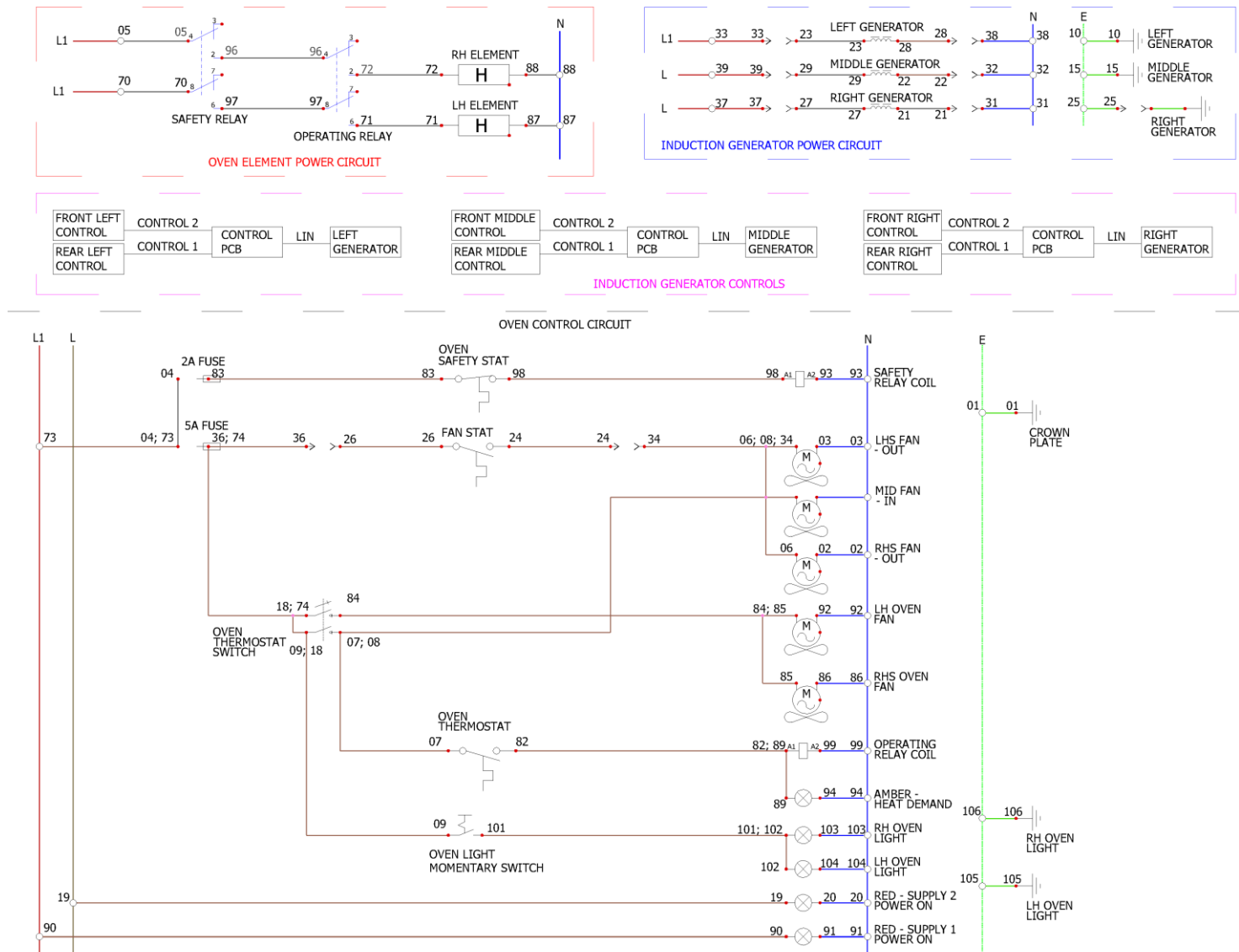

9.16.2 E163i Circuit Diagram

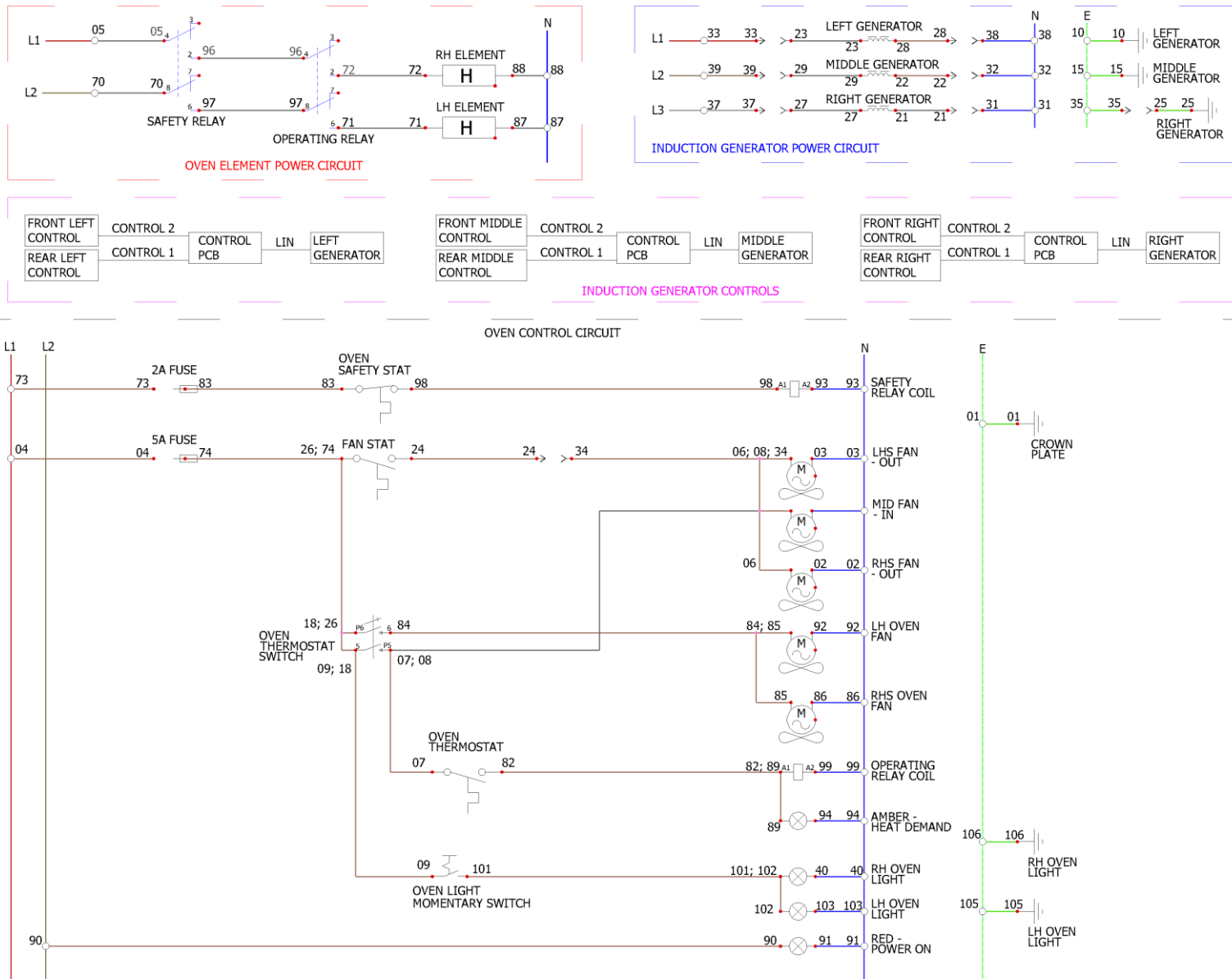

9.16.3 E143i Circuit Diagram

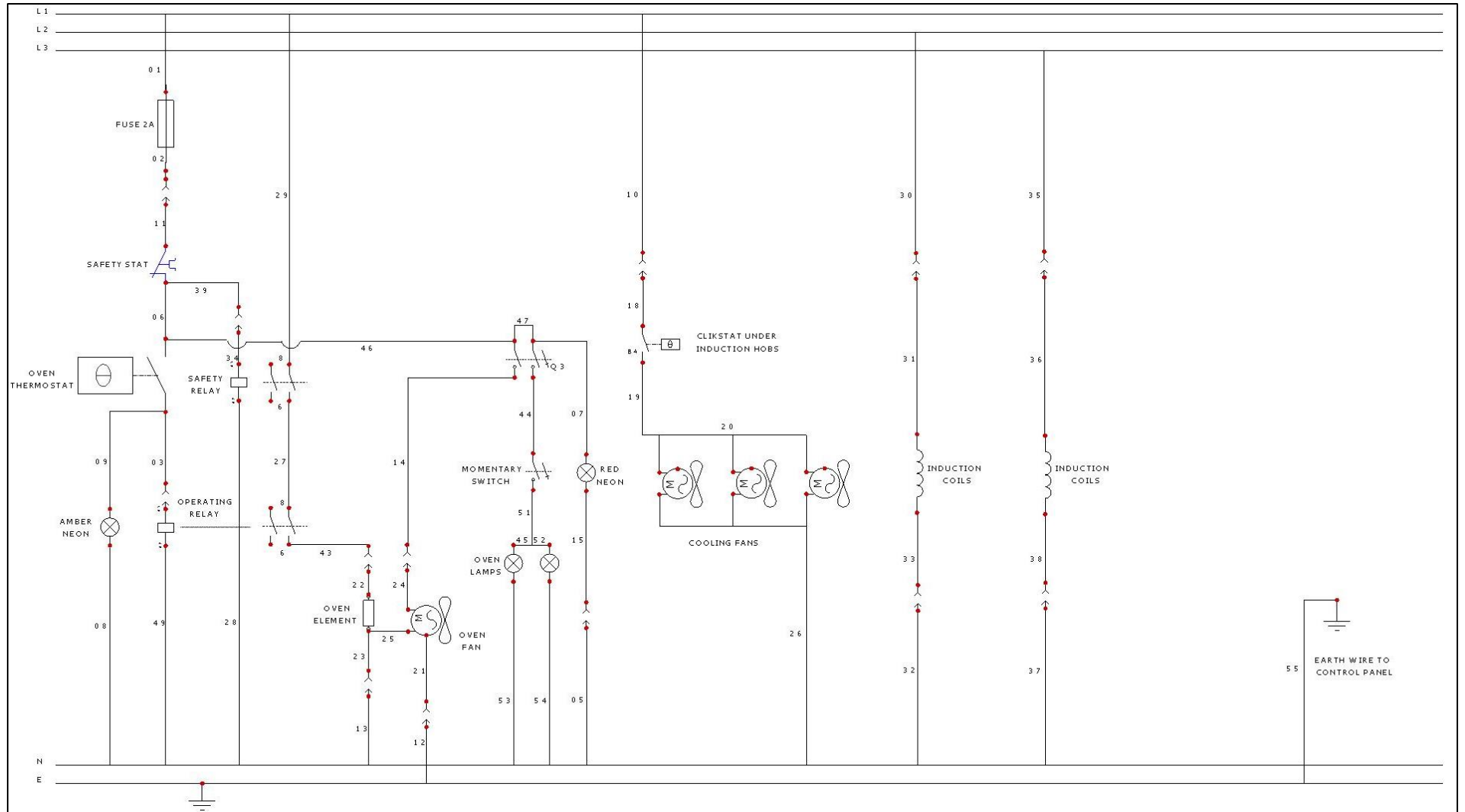

9.17 WIRING DIAGRAMS

9.17.1 E161i Wiring Diagram

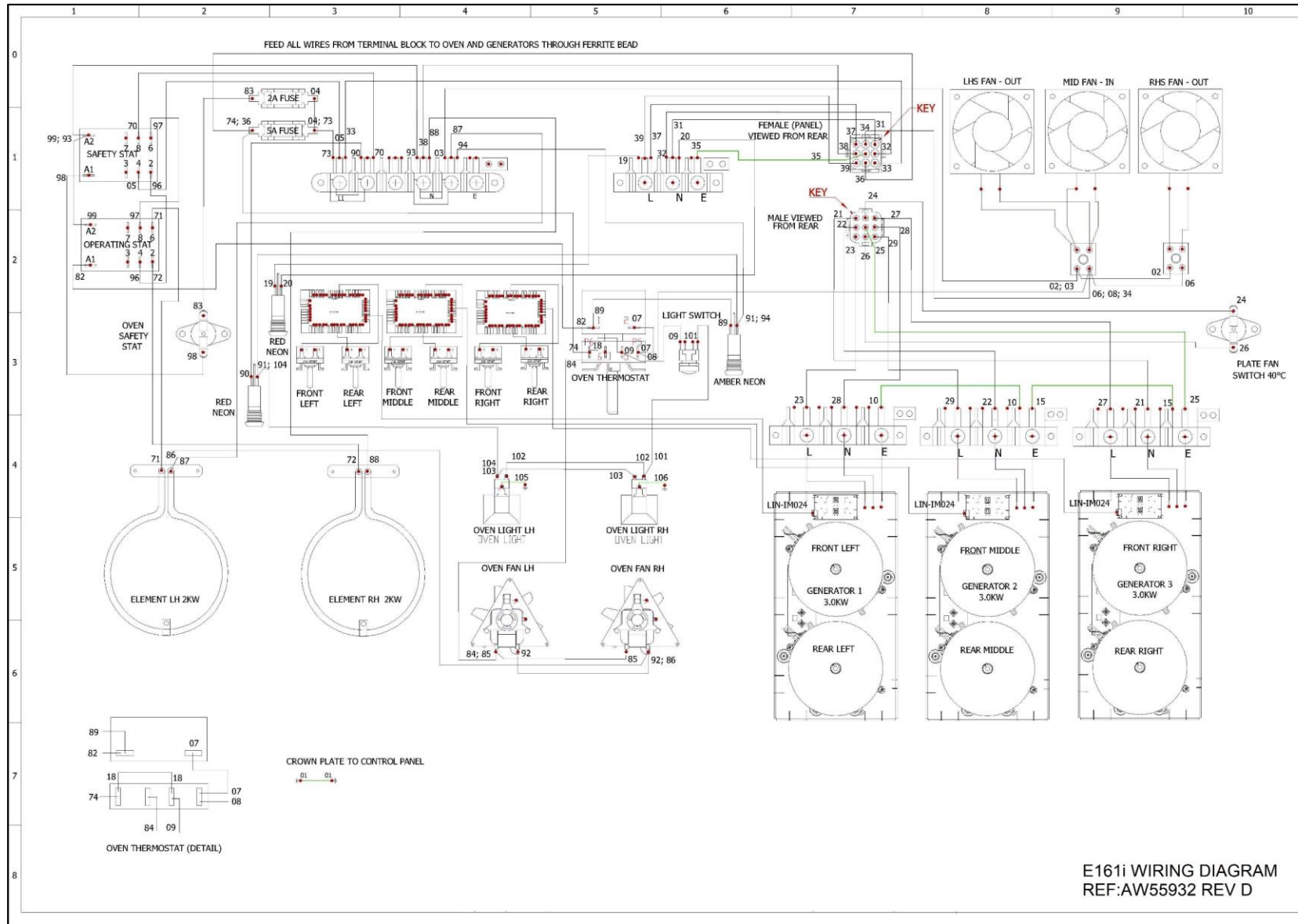

9.17.2 E163i Wiring Diagram

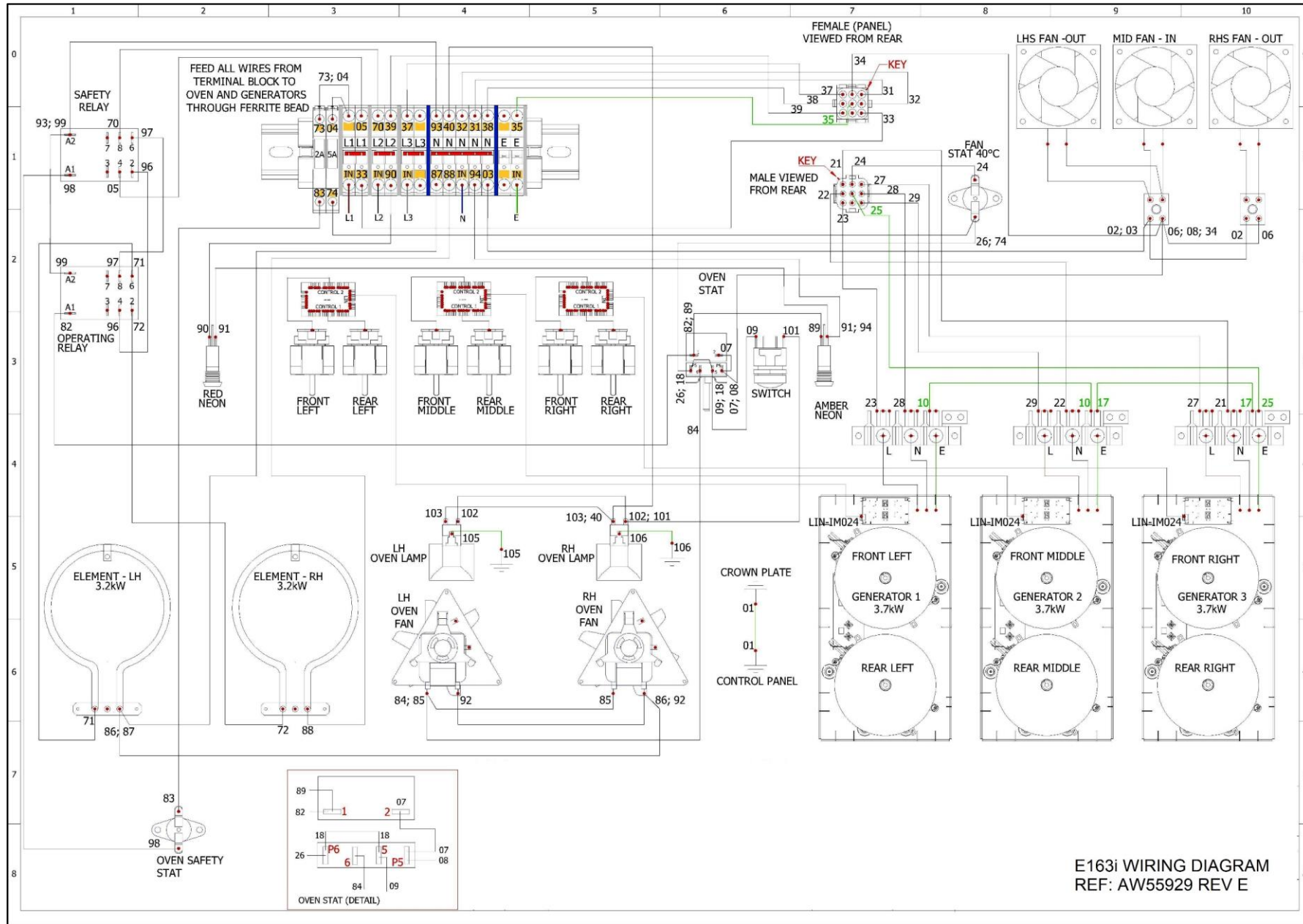

9.17.3 E143i Wiring Diagram

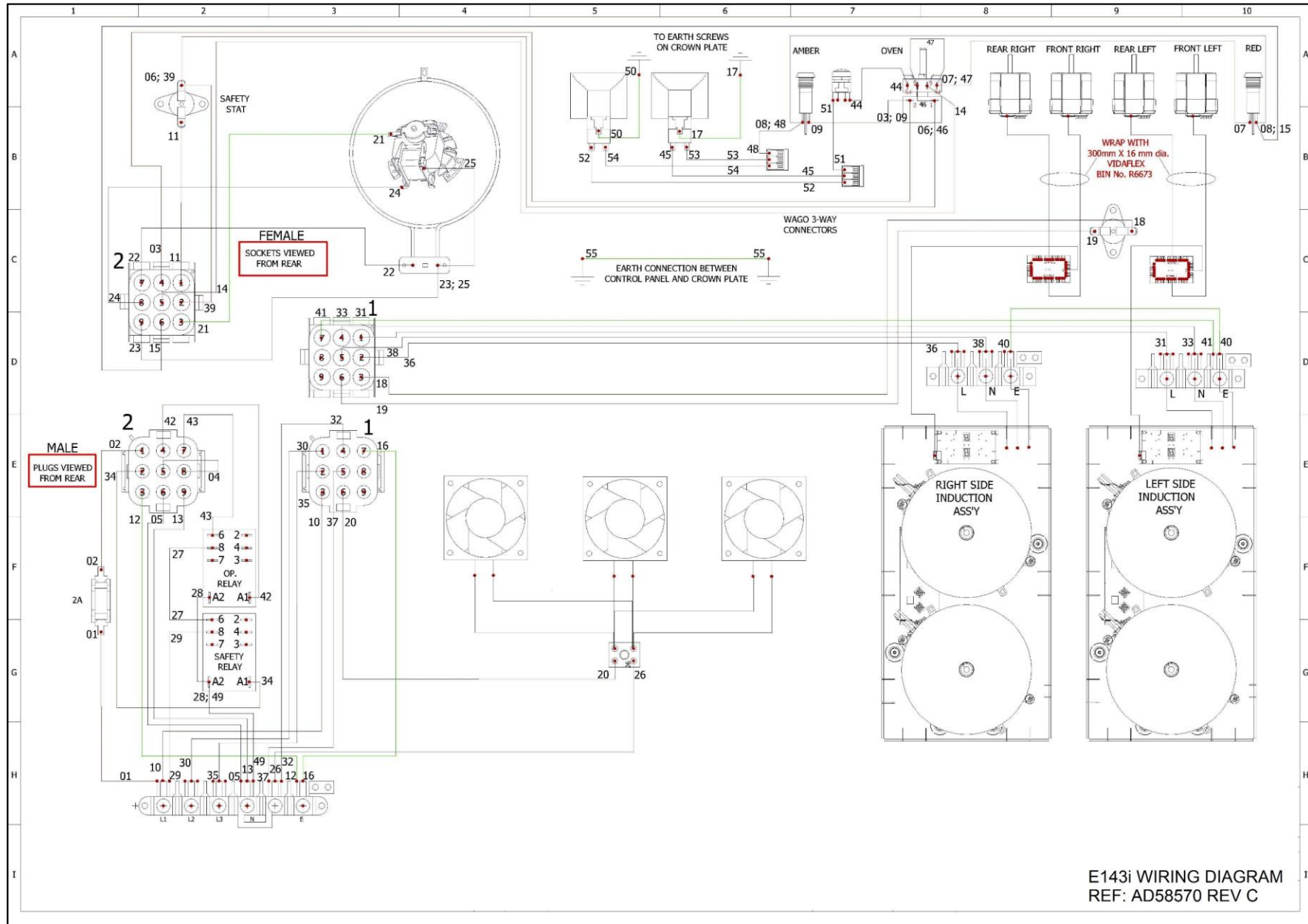

10.0 FAULT FINDING

10.1 ERROR CODES

10.1.1 Most faults can be rectified by simply switching unit off for 10 seconds. After this time, turn power back on at mains supply. If fault continues to occur, please refer to the table below. This will provide a solution to rectify the condition.

<u>FAULT</u>	POSSIBLE CAUSES	REMEDY	USER	*ENG
Unit will not turn ON	No power to unit	Check mains power is connected and turned on	✓	
	Fuse has blown	Call Engineer	✓	
Hob cooking zones will not operate	Control knob at off position	Rotate hob control knob clockwise to switch on.	✓	
Reduced performance on hob cooking zones.	Blocked air filter	Clean Air filter (See section 3.1.2)	✓	
	Damaged pan	Replace pan	✓	
Oven will not operate	Safety stat tripped	Call Engineer	✓	
Oven not heating	Faulty Element	Call Engineer	✓	

Induction Hob Error Codes.

ERROR CODE	DESCRIPTION	POSSIBLE CAUSE OF ERROR	REMEDY
E / 2	Excess temperature of the induction element	Overload of cooktop or empty boiled cookware	Switch off. Let system cool down.
Er 20	Flash memory – TC error	µC- defective	Replace generator
Er 22	Button evaluation defective, UI shuts off after 3.5-7.5 sec	Short or open circuit in the area of the button sensorics	Replace generator
Er 31	Incorrect configuration data or deviation between generator and Controls	New configuration of the induction generator required	Replace generator
Er 36	NTC value defective on Control; UI turns off	Short or open circuit of NTC	Replace generator
Er 47	Communication error between TC and induction	No or erroneous LIN communication! (Slave does not answer to request of master)	Connection cable not correctly plugged in or defective.
U 400	Continuous tone Power supply on inlet too high	Incorrect connection of the cook top	The cook top Correct power supply connection
E / A	Error on the power board	Component failure	Replace generator
E / 6	Error on power board or supply element	No power supply of the power element or error on power board	1. Check wiring 2. Replace generator
E / 7	Mains connection error Issue	Incorrectly wired	1. Check mains supply wiring
E / 8	Incorrect fan speed	Error on fan left or right	1. Air exhaust blocked, e.g. by paper 2. Replace Generator
E / 9	Defective temperature sensor on inductor		Replace generator

PROBLEM	POSSIBLE CAUSES	REMEDY	USER	*ENG
Food keeps burning	Oven dial setting too high	Lower dial setting	✓	

*ENG Service engineer only.

11.0 SPARE PARTS

PART DESCRIPTION	SPARES NUMBER
Power neon red	730962010
Heat demand neon amber	730962040
Oven temperature control knob	535300004
Induction zone control knob	733990003
Oven operating thermostat	535420006
Coding switch	733990006
Oven safety thermostat	535420015
Oven door seal assembly	535210001
Rear hob cooling fan	735400360
Hob cooling thermostat	733990011
Oven fan	535420010
Oven light switch	535500037
Oven light bulb	734350190
Oven lamp assembly c/w glass	732910390
E161i Control panel	733990001
E161i Oven element 2kw	733990000
E161i Induction Heater (13A)	733990004
E163i Control panel	733990002
E163i Oven element 3.2kw	535420009
E163i & E1403i Induction Heater (16A)	733990005

When ordering spare parts please quote the following:

Model Number

Serial number

This information will be found on data plate attached to the appliance

Visit our website for further spares information.

12.0 SERVICE INFORMATION

This unit carries an extensive mainland UK warranty. The warranty is in addition to and does not change your statutory or legal rights.

The warranty policy can be found on our website which details the conditions of the warranty and the exclusions.

<https://www.falconfoodservice.com/info-centre/policy>



Service calls to equipment under warranty will be carried out in accordance with the conditions of sale.

Warranty calls can be made between 8:30 am and 5:00 pm weekdays only.

To ensure your warranty enquiry is handled as efficiently as possible, ensure you have the following appliance information prior to calling us:

1. Model number – found on data plate
2. Serial number – found on data plate
3. Brief description of the issue

To contact Falcon for a warranty issue dial (UK only) 01786 455 200 and select Warranty Issues from the menu.