



## Installation, Operating and Servicing Instructions

Opus 800 Electric Chargrills  
OE8405, OE8406.

Please make a note of your product details for  
future use:

Date Purchased: \_\_\_\_\_

Model Number: \_\_\_\_\_

Serial Number: \_\_\_\_\_

Dealer: \_\_\_\_\_

\_\_\_\_\_

*Opus* **800**

# CONTENTS

Important Information	2
Warnings and Precautions	3
Technical Data	3
Checklist of Enclosures	3
Installation and Commissioning	4
Operating Instructions	6
Cleaning	8
Servicing, Maintenance and Component Replacement	9
Fault Finding	11
Spare Parts List	11
Accessories	12
Service Information and Guarantee	13

## IMPORTANT INFORMATION

---



Read these instructions carefully before using this product, paying particular attention to all sections that carry warning symbols, caution symbols and notices. Ensure that these are understood at all times.

---



### **WARNING!**

This symbol is used whenever there is a risk of personal injury.

---



### **CAUTION!**

This symbol is used whenever there is a risk of damaging your Lincat product.

---

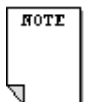

### **NOTE:**

This symbol is used to provide additional information, hints and tips.

---

**KEEP THIS MANUAL FOR FUTURE REFERENCE**

## WARNINGS AND PRECAUTIONS



This appliance must be installed, commissioned and serviced by a qualified person in accordance with national and local regulations in force in the country of installation.

If the supply cord is damaged, it must be replaced by the manufacturer, its service agent or similarly qualified person.

Ensure that the plug/socket is accessible at all times.

Strip plastic coating and clean the appliance before use.

During operation parts may become hot - avoid accidental contact.

Disconnect this appliance before servicing, maintenance or cleaning.

## TECHNICAL DATA

	OE8405	OE8406	OE8406 Dual Supply
Height (mm)	415		
Width (mm)	600	900	
Depth (mm)	800		
Weight (kg)	57	71	
Element Rating (kW)	8.4	12.4	2 x 6.2
Supply 3N~+E 400V 50-60Hz Current (A)	L1 12.2 L2 12.2 L3 12.2	L1 18 L2 18 L3 18	2 x L1 9 2 x L2 9 2 x L3 9
Power Rating (kW)	8.4	12.4	
Water inlet (BSPT)	1/2"		
Water overflow (Dia.mm)	22		
Water fill valve (Dia.mm)	15		

## CHECK LIST OF ENCLOSURES

Warranty card
Instructions manual
Legs x 4
Water level indicator
Splashguard
Branding plates
Slip stop washers
Scraper

# INSTALLATION AND COMMISSIONING

This appliance must be earthed.



An equipotential bonding terminal is provided to allow cross bonding with other equipment.

If replacing the plug connect the terminals as follows:

Green and Yellow wire	Earth	E
Blue wire	Neutral	N
Brown wire	Live	L

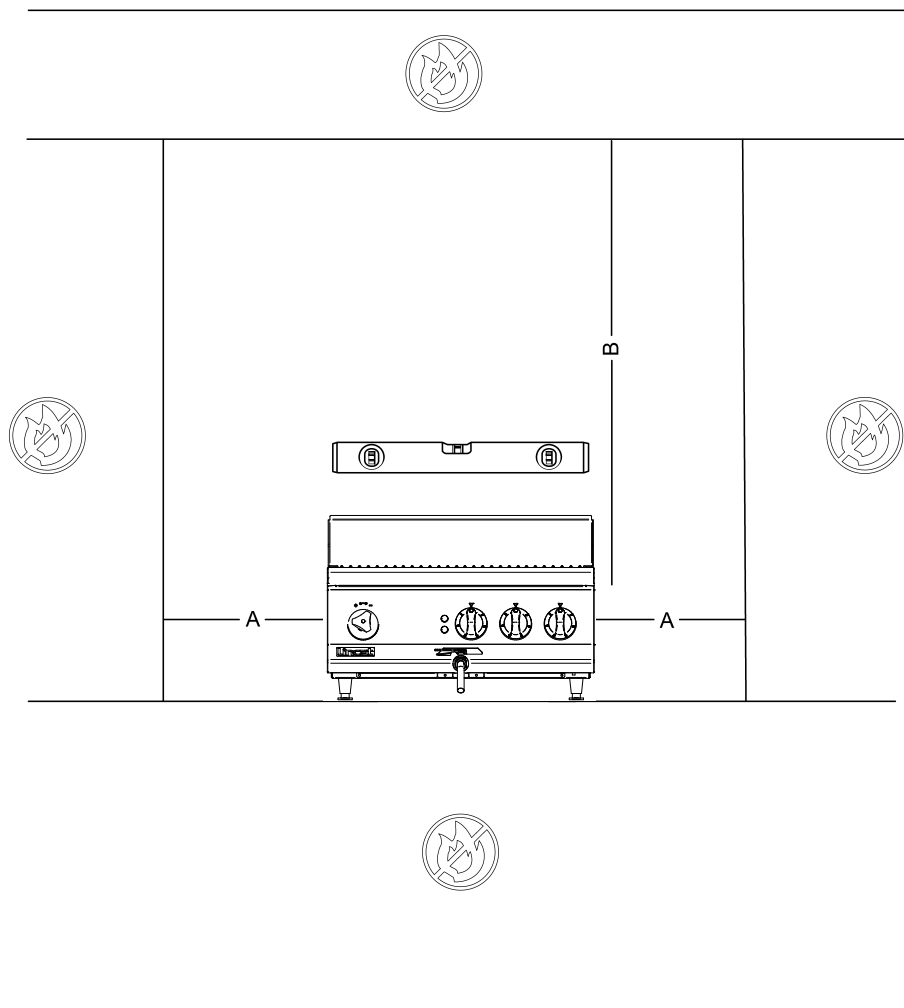

Fig 1

Means of isolation with at least 3mm contact separation in all poles must be incorporated into the fixed wiring of this appliance.

The fixed wiring insulation must be protected by insulated sleeving having a temperature rating of at least 60 Deg C.

Supply cords shall be oil resistant, sheathed flexible cable not lighter than ordinary polychloroprene or equivalent elastomer sheathed cord (code 60245 IEC 57)

Install this appliance on a level surface ensuring all vents are unobstructed. Any partitions, walls or furniture must be of non-combustible material. Minimum distances A 100mm B 1000mm – see Fig 1.

Ensure there is a space of at least (1000 mm) between the working surface and any ceiling.

Install this appliance beneath an extraction canopy.

Connection of the supply cable is behind the fascia panel at the front of the appliance. Remove the fascia and fit a suitable cable through the cable guide to the terminal block.

Connection to a mains water supply is provided at the rear of the appliance. There is also an overflow pipe that must be connected to a waste outlet in case of accidental overflowing of the tank. The appliance must not be operated without water in the tank, as it will result in the operation of the safety cut-out beneath the fascia panel. (See operating instructions). Check the fill rate. If it is considered excessive, source and fit a flow restrictor.

The appliance may be manually filled via the fill box at the front of the appliance. However, we do not recommend this as the regular way to fill the tank.

When the appliance has been installed in the intended position, the legs should be adjusted to maintain a level top. Use a spirit level to determine that the chargrill is level left to right and front to back. This procedure is critical, as it can affect the safety cut-out operation and also assist the drainage of the appliance.

Anti-slip washers are provided to create a slip free pocket for the front feet, so preventing movement during operation. Ensure the work surface is structurally safe before installing the washers.

Ensure that the operator understands how to fill the water tank, safely operate, shutdown and clean the appliance, and is aware of the position of the isolating switch.

# OPERATING INSTRUCTIONS

Only qualified or trained personnel should use this appliance.

This appliance should not be operated unattended.

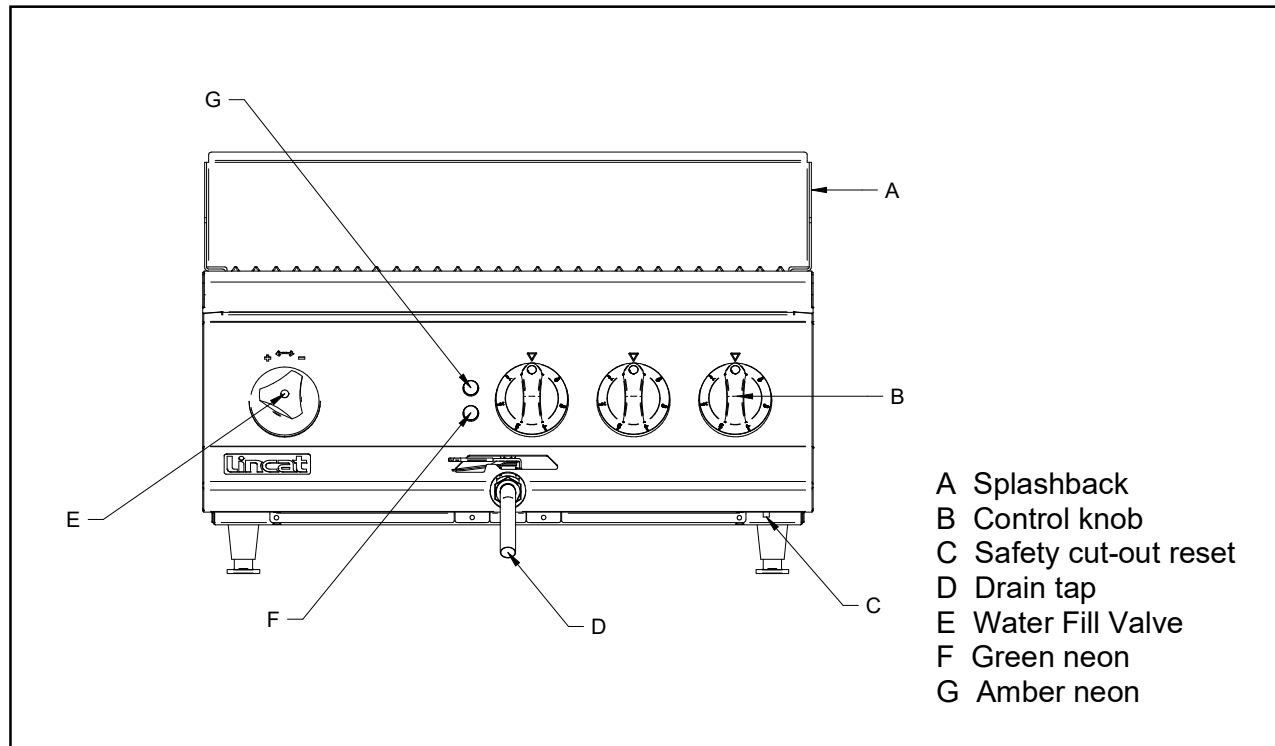

Fig 2

## Preparation

Before first use, wash the branding plates, dry immediately and coat with a thin film of cooking oil to encourage a coating which resists rust. Operate the appliance without any food products to season the branding plates. During the lifetime of the appliance, repeating this coating process whenever the coating has been removed will prevent rust on the branding plates. Do not put the branding plates into a decarboniser.

## Filling

Open the water fill valve anticlockwise to fill the tank, closing the valve as soon as the water level in the fill tank reaches the “Max Fill Level” (Fig 3). As a secondary measure, ensure the water level does not fall below the lower leg of the level gauge (Fig 3).

If a mains water supply is not available, the appliance can be hand filled via the fill tank at the front of the unit. Do not pour water directly on the grill area or element.

If the appliance starts to overflow before the water level reaches the “Max Fill Level”, the rear legs should be adjusted up, so that the unit sits level. When the level has been reached, close the valve without over-tightening.

For optimum use, keep the water inlet set to a trickle feed for continuous filling of the tank.

NB.

If the water level is not maintained the safety cut-out will operate. The appliance will then need to be cooled before the cut-out can be reset. Reset by pressing the red safety cut-out button (C) beneath the fascia (Fig 2). When refilling with water after overheating, extreme caution should be used, as cold water may react with the contents if they have been allowed to build up and become volatile.

For additional safety, the OE8406 has two safety cut-outs, BOTH of which will need resetting in the event of a fault.

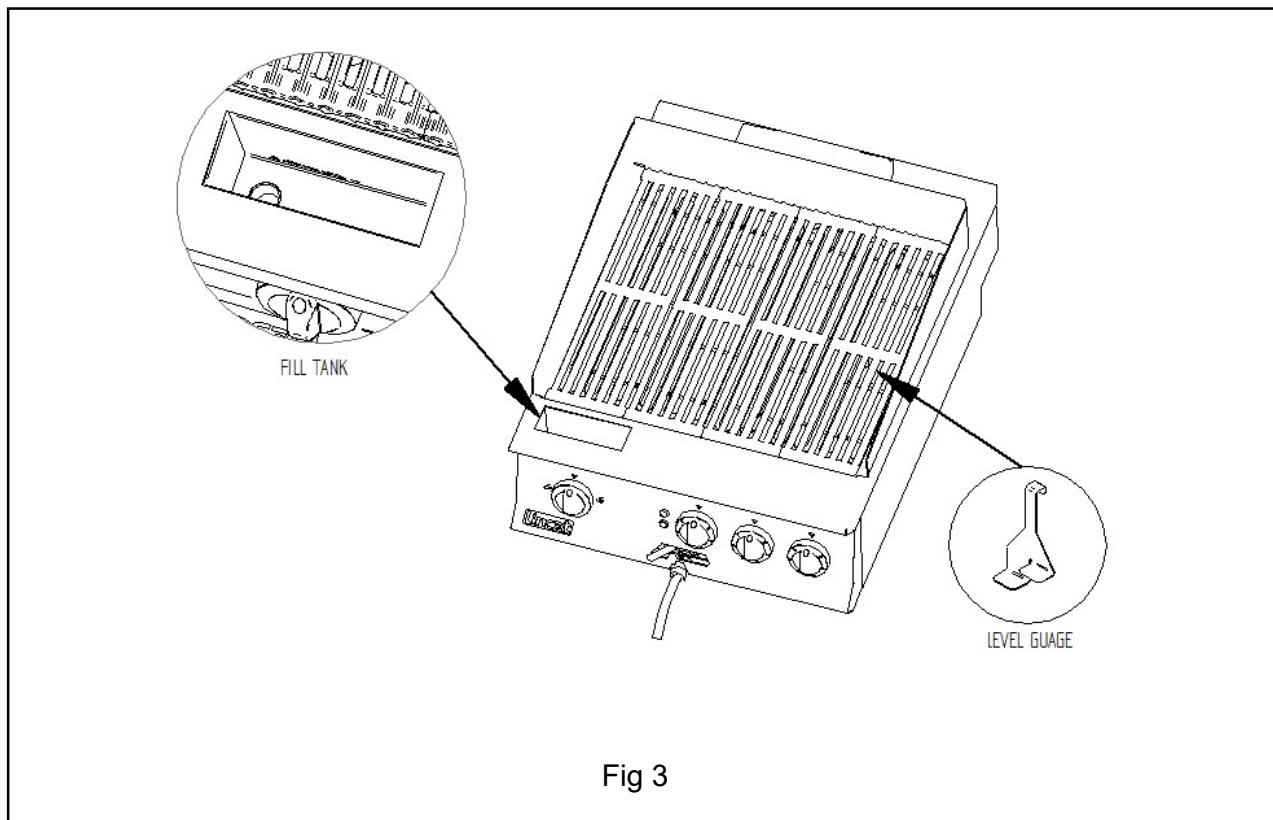

## Operating

Switch on the power supply at the isolating switch – the green neon will illuminate.

OE8405 – The branding plates create one large cooking zone, divided into three equal areas, each independently controlled.

OE8406 – The branding plates create one large cooking zone, divided into six equal areas, each independently controlled.

Turn the control knobs to the desired setting. On settings 1-5 the elements will cycle to maintain the temperature. On setting 6 the elements remain on constantly.

To turn the appliance off after cooking, rotate all control knobs to the 'Off' position, and turn off both electrical supply and water supply.

## CLEANING



Do not use a water jet or steam cleaner, and do not immerse this appliance.

Clean all panels with warm water and mild detergent, do not use abrasive materials. Dry with a soft cloth.

After the appliance has cooled, remove the branding plates, splashguard and water level indicator. Lift and lock the element up, ensuring the stay is securely latched.

Remove any food debris from the tank and pour a quantity of warm soapy water into the tank to assist with draining.

Drain the tank into a receptacle, and then clean all exterior panels with warm water and mild detergent. Do not use abrasive materials or any products containing chlorine or hydrochloric acid. Dry with a soft cloth.

Clean and dry the branding plates – for stubborn deposits a de-greasing agent 'Carbon-Off' is available from Lincat.

Lower the elements and replace all removable parts correctly.

Coat the branding plates lightly with cooking oil to avoid rusting.

# SERVICING, MAINTENANCE AND COMPONENT REPLACEMENT

Your Lincat product has a manufacturer's warranty. This requires you to maintain and care for your product and follow maintenance instructions. If you fail to maintain your unit or damage components Lincat may charge you for a warranty repair. Please check the website for terms and conditions.

All servicing, maintenance and component replacement on this appliance should be carried out by one of our recommended service engineers.

## **Routine Service**

Carry out a general check of the installation paying particular attention to the following:

The suitability of the supply cable.

The installation of isolation points for electricity and water.

The correct operation of all components.

Non leakage of the tank

Non leakage of all water carrying components.

## **Component replacement**

### **Element**

Remove the branding plates, level indicator and splash back.

Remove the screws securing the lifting box cover, tilt the cover forward, unhook and lift away.

Disconnect the electrical terminals, marking each to assist with reassembly.

Remove the aero nuts securing the element bracket to the lifting box. Remove the element and transfer the screws to the new element.

Reverse the above procedure to reassemble the appliance.

### **Cut out switch in lifting box**

Remove the branding plates, level indicator and splash back.

Remove the screws securing the lifting box cover, tilt the cover forward, unhook and lift away.

Remove the cables and transfer to the new switch.

Remove the old switch and reassemble by reversing the above sequence.

### **Neon**

Pull off the filling tap handle, taking care not to lose the blue pip, and remove the filling tap bezel if required.

Remove the screws securing the fascia to the base panel. Remove all control knobs and free the fascia by pulling towards you from the bottom.

Remove the cables from the neon and free the neon by unscrewing the retaining collar.

Fit new neon and reverse the procedure to reassemble; using adhesive to secure the bezel if removed.

### **Energy regulator**

Remove the fascia as detailed for neon replacement above.

Disconnect cables from the energy regulator terminals and fit to new regulator.

Unscrew the old regulator and refit the new regulator by reversal of the above procedure.

### **Safety thermostat**

Remove the fascia as detailed above.

Remove the safety thermostat retaining screws. Loosen the phial bracket screws until you can ease out the phial.

Replace the old thermostat with the new one and reverse the above procedure to reassemble the appliance.

Check the appliance for electrical safety.

## Contactor

Pull off the filling tap handle, and remove the facia as detailed for neon replacement above.

Unclip the contactor from the bracket.

Transfer the cables one at a time to the new contactor using a thin screwdriver to release the wiring clamps.

Refitting is the reversal of removal.

Check the appliance for electrical safety.

## FAULT FINDING

Please refer to the Service Help Desk number on the final page of this manual.

## SPARE PARTS LIST

Part Number	Description	Used on
BP37	Branding plate	OE8405, OE8406
CO167	Fill valve	
CO215	Contactor	
EL313	Element	OE8405
EL314	Element	OE8406
EN10	Energy regulator	OE8405, OE8406
KN511	Control knob	
LE38	Leg	
NE46	Green neon	
NE47	Amber neon	
RO02	Scraper	
SW64	Micro switch	
TH73	Safety thermostat	
DS24	Drain valve	
TU48	Drain Tube	

## ACCESSORIES

Part Number	Description	Used on
OA8917	Floor stand	OE8405
OA8914	Floor stand	OE8406
OA8949	Griddle plate	All

## SERVICE INFORMATION

For help with the installation, maintenance and use of your **Lincat** equipment, please contact our service department:

**☎ UK: 01522 875520**

For non-UK customers, please contact your local Lincat dealer

All service work, other than routine cleaning should be carried out by one of our authorised service agents. We cannot accept responsibility for work carried out by other persons.

To ensure your service enquiry is handled as efficiently as possible, please tell us:

- Brief details of the problem
  - Product code
  - Type number
  - Serial number
- } All available on serial plate

Lincat reserve the right to carry out any work under warranty, given reasonable access to the appliance, during normal working hours, Monday to Friday, 08:30 to 17:00.

### GUARANTEE

This unit carries a comprehensive UK mainland 2 year warranty. The guarantee is in addition to, and does not diminish your statutory or legal rights.

The guarantee does not cover:

- Accidental damage, misuse or use not in accordance with the manufacturer's instructions
- Consumable items (such as filters, glass, bulbs, slot toaster elements and door seals.)
- Damage due to incorrect installation, modification, unauthorised service work or damage due to scale, food debris build-up, etc.

The manufacturer disclaims any liability for incidental, or consequential damages. Attendance is based on reasonable access to the appliance to allow the authorised technician to carry out the warranty work.

Service calls to equipment under warranty will be carried out in accordance with the conditions of sale. Unless otherwise specified, a maximum of 15 minutes of administrative time, not spent directly carrying out servicing work, is provided for within the warranty. Any requirement for staff attending the call to spend greater time than 15 minutes due to administrative requirements, such as on health and safety risk assessments, will be chargeable at the prevailing rate.