



IMC SP12H FLOOR-MOUNTED POTATO PEELER - 1 PHASE - H 1400
MM - 0.37 KW

MODEL: F58/902



SP
PEELER

The efficient, upright IMC Potato Peeler ensures short preparation times which in turn reduces costly wage bills and makes for better staff utilisation. Ideal for medium and large scale operations, the peeler comes with reversible corrosion-proof liners. With a capacity of 12kg, it takes two minutes to peel a full batch of potatoes. The peeler is a perfect height for emptying into a sink and is hygienic and easy to clean.

A/A FILE NUMBER:

PRODUCT OPTIONS AND ACCESSORIES

- S58/568 Filter Basket - Integral - for SP Potato Peeler
- S58/569 Interceptor Tank - for SP Potato Peeler [pedestal mounted/2" BSP]
- A29/003 Lid Retaining Strap for SP/VQ Potato Peeler
- S58/570 Waste Ejector for SP Potato Peeler [2" BSP]

PRODUCT FEATURES

- Upright design - ideal for medium and large scale operations
- Perfect height to empty into a sink
- Hygienic and easy to clean
- WRAS approved Class A air-break and brass spray nozzle prevents any back siphonage of water into the mains supply
- Reversible corrosion-proof liners
- Dual position for waste outlet
- 2 minutes to peel a batch of 12 kilos of potatoes
- Single phase

ITEM NUMBER:



IMC SP12H FLOOR-MOUNTED POTATO PEELER - 1 PHASE - H 1400
MM - 0.37 KW

MODEL: F58/902

WEIGHTS & DIMENSIONS

Width	530 mil
Depth	624 mil
Height	1388 mil
Weight	50.5 kg

SHIPPING DETAILS

Ship Width	68 cm
Ship Depth	57 cm
Ship Height	148 cm
Ship Weight	55.55 kg
Ship Method	Small Parcel (FedEx, UPS, DHL)
Shipping Package Type	Pieces
Shipping Origin Zip Code	LN6 3QZ, UNITED KINGDOM
Quick Ship Product	No

WATER, PLUMBING, AND DRAINAGE SPECS

Water Line Required	Yes
Water Connection Source Type	Water Main
Water Inlet Size	12 mm
Water Inlet Pressure Minimum	2.7 Bar
Water Inlet Pressure Maximum	3.8 Bar
Drain Line Required	Yes
Drain Location	Right or Left
Drain Outlet Size	54 mm

PRODUCT CERTIFICATIONS



ENERGY SPECS

Primary Energy Type	Electric	Electrical Plug Type	UK 3-Pin Plug
Electrical Total Amperage	6.2 A	Number of Electrical Plugs	1
Electrical Volts	230V	Electrical Connection Type	Cord and Plug
Electrical Total Wattage	370 W	Number of Electrical Conductor Wires	1
Electrical Kilowatts	0.37 kW	Dedicated Circuit Required	No
Electrical Phase	1-Phase	Electrical Remarks	Single

ADDITIONAL SPECIFICATIONS

Airbreak	Yes
Construction Materials	Stainless Steel
Control Type	On/Off
Hopper Load	12 kg
Motor Power	0.5 hp
Operator Safety Method	User Guide
Processing Capacity Per Hour	220 kg
Timer Type	Mechanical/Traditional Timer

IMC reserves the right to modify specifications or discontinue models without incurring obligation. Dimensions nominal.

Document Auto-Generated
March 24, 2025



IMC SP12H FLOOR-MOUNTED POTATO PEELER - 1 PHASE - H 1400
MM - 0.37 KW

MODEL: F58/902

BIDDING SPECIFICATIONS (SHORT FORM SPECS)

Bidding Specifications Not Available.

TECHNICAL DRAWING

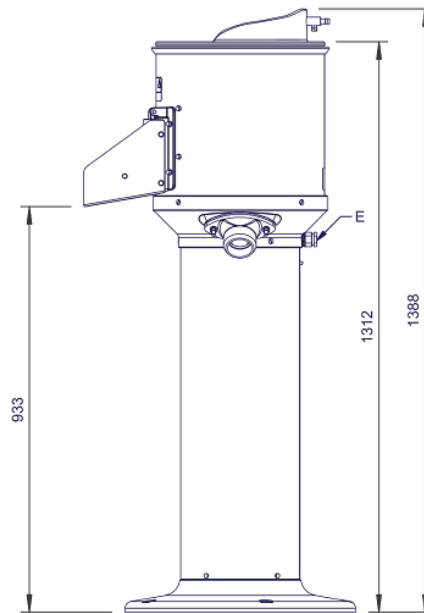
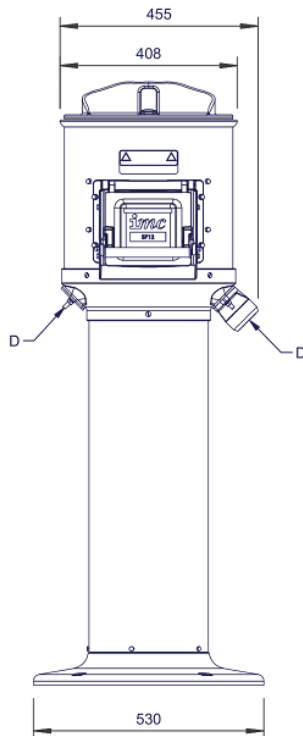
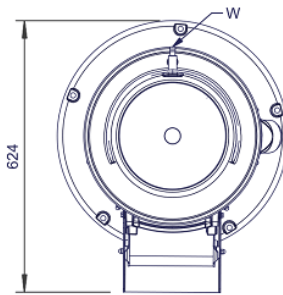

IMC reserves the right to modify specifications or discontinue models without incurring obligation. Dimensions nominal.

Document Auto-Generated
March 24, 2025