



User, installation, and servicing instructions

# ELECTRIC GLASS-TOP RANGE

E3164  
E3196

Read these instructions before use.

DATE PURCHASED:

---

MODEL NUMBER:

---

SERIAL NUMBER:

---

DEALER:

---

SERVICE PROVIDER:

---

T101113

Rev No 3  
Published: 16/04/25

Dear Customer

Thank you for choosing Falcon Foodservice Equipment.

This manual can be downloaded from [www.falconfoodservice.com](http://www.falconfoodservice.com) or scan here:



**IMPORTANT:** Please keep this manual for future reference.

### Original Instructions

### Falcon Foodservice Equipment

#### HEAD OFFICE

Wallace View, Hillfoots Road,  
Stirling. FK9 5PY. Scotland.  
Tel: 01786 455200

### PREVENTATIVE MAINTENANCE CONTRACT

To obtain maximum performance from this unit regular servicing of the appliance should be undertaken to ensure correct operation, it is functioning as intended, and safe to use. We recommend servicing in accordance with SFG20 Maintenance Schedules and as a minimum, after 2,500 hours of use, or annually, whichever comes first and that a maintenance contract be arranged with an appointed service contact. Visits may then be made at agreed intervals to carry out adjustments and repairs.



### WEEE Directive Registration No. WEEE/DC0059TT/PRO

At end of appliance life, dispose of appliance and any replacement parts in a safe manner, via a licensed waste handler. Appliances are designed to be dismantled easily and recycling of all material is encouraged whenever practicable.

# CONTENTS

---

<b>1.0</b>	<b>SYMBOLS</b> .....	<b>4</b>
<b>2.0</b>	<b>SAFETY GUIDANCE</b> .....	<b>5</b>
2.1	GENERAL SAFETY .....	5
2.2	INSTALLATION SAFETY .....	6
2.3	ELECTRICAL SAFETY .....	7
2.4	FIRE SAFETY .....	7
2.5	MAINTENANCE SAFETY.....	8
<b>3.0</b>	<b>APPLIANCE INFORMATION</b> .....	<b>10</b>
<b>4.0</b>	<b>OPERATION</b> .....	<b>11</b>
4.1	COMPONENT PARTS & CONTROLS .....	11
4.2	USING THE APPLIANCE – HOB .....	13
4.3	USING THE APPLIANCE – OVEN .....	13
<b>5.0</b>	<b>CLEANING</b> .....	<b>14</b>
5.1	CLEANING – HOB .....	14
5.2	CLEANING - OVEN.....	15
5.3	CULINARY GUIDANCE .....	17
<b>6.0</b>	<b>SPECIFICATION</b> .....	<b>18</b>
6.1	APPLIANCE WEIGHT TABLE.....	18
6.2	TECHNICAL DATA TABLE .....	18
<b>7.0</b>	<b>DIMENSIONS / CONNECTION LOCATIONS</b> .....	<b>19</b>
<b>8.0</b>	<b>INSTALLATION</b> .....	<b>20</b>
8.1	SITING / CLEARANCES .....	20
8.2	ASSEMBLY .....	22
8.3	ELECTRIC SUPPLY & CONNECTION.....	22
8.4	COMMISSIONING .....	24
<b>9.0</b>	<b>SERVICING</b> .....	<b>24</b>
9.1	CONTROL PANEL AND HOB ACCESS.....	24
9.2	COOLING FAN REMOVAL .....	26
9.3	ELECTRIC BOX ACCESS.....	28
9.4	DOOR REMOVAL .....	29
9.5	RELAY REMOVAL .....	29
9.6	OVEN ELEMENTS REMOVAL.....	29
9.7	HOB ELEMENTS REMOVAL .....	31
9.8	OPERATING THERMOSTAT REMOVAL.....	31

9.9	SAFETY THERMOSTAT REMOVAL.....	32
9.10	SAFETY THERMOSTAT RESET .....	33
9.11	NEON REMOVAL .....	33
9.12	CIRCUIT DIAGRAMS.....	35
9.13	WIRING DIAGRAMS .....	37
<b>10.0</b>	<b>ACCESSORIES .....</b>	<b>40</b>
<b>11.0</b>	<b>FAULT FINDING.....</b>	<b>40</b>
<b>12.0</b>	<b>SPARE PARTS.....</b>	<b>41</b>
<b>13.0</b>	<b>SERVICE INFORMATION.....</b>	<b>41</b>

## 1.0 SYMBOLS

---



**WARNING**



**SCREWDRIVER**



**SPANNER**



**GREASE**



**HEX BOLT  
EXTRACTOR**

## 2.0 SAFETY GUIDANCE

---

### 2.1 GENERAL SAFETY



2.1.1 These instructions are only valid if the country code appears on the appliance. If the code does not appear on the appliance, refer to the technical instructions for adapting the appliance to the conditions for use in that country.

2.1.2 These appliances have been UKCA/CE-marked based on compliance with the Electrical and Electromagnetic Compatibility (EMC) Regulations/Directives for the Countries as stated on the data plate.



2.1.3 These appliances are for professional use only and must be used by qualified persons.

2.1.4 Never leave these appliances unsupervised when in use and always turn off at the end of service.



2.1.5 The installer must instruct the responsible person(s) of the correct operation and maintenance of these appliances.

2.1.6 Check that no damage has occurred to the appliance or supply cord during transit. If damage has occurred, do not use this appliance.



2.1.7 If fitted to the appliance, ensure the supply cord is routed free from the appliance to avoid damage.



2.1.8 Suitable Protective clothing must be worn when topping up whilst the fryer is hot.

2.1.9

2.1.10 Training and Competence: To help ensure the safe use of these appliances there is a requirement for you to provide whatever information, instruction, training, and supervision as is necessary to ensure, so far as is reasonably practicable, the health and safety of all users.

2.1.11 For further help and information on training and competence we refer you to the Health & Safety Executive website; <a href="http://www.hse.gov.uk">www.hse.gov.uk</a> document ref: health and safety training INDG345. International customers should default to the health and safety guidelines provided by your government body.
---

	<p>2.1.12 Risk Assessment: As part of managing the health and safety of your business you must control any risks identified in your commercial kitchen. To do this you need to think about what might cause harm to people and decide whether you are taking reasonable steps to prevent that harm. This is known as risk assessment. It is important to consider the environment around the product as well as the product itself. For example, oil or food spills will present a significant risk so users so the need to immediately clean up such spills must be reflected in staff training.</p>
	<p>2.1.13 Record the training that you provide and support it by providing safe system of work (SSOW) documents that set out procedures to be followed for potentially hazardous tasks.</p>
	<p>2.1.14 For further help and information on risk assessments we would refer you to you the Health and Safety Executive website; <a href="http://www.hse.gov.uk">www.hse.gov.uk</a> document ref: risk assessment INDG163. International customers should default to the health and safety guidelines provided by your government body.</p>

## 2.2 INSTALLATION SAFETY



- 2.2.1 Installation must meet national or local regulations. Attention must be paid to safety (installation & use) regulations, health and safety at work act, local and national building regulations, fire precautions act.
- 2.2.2 The installer must instruct the responsible person(s) of the correct operation and maintenance of the appliance.
- 2.2.3 On gas appliances, only competent persons are allowed to service or convert the appliance to another gas type.
- 2.2.4 Put a documented system in place for periodic inspections, testing and maintenance of our gas/~~electrical~~ appliances. Check that the fixed electrical installation has been inspected and tested by a competent electrical contractor (e.g. NICEIC-approved or ECA member) as prescribed in BS7671, within the last 5 years.

## 2.3 ELECTRICAL SAFETY



- 2.3.1 To prevent shocks, this appliance must be earthed.
- 2.3.2 This unit is fitted with an equipotential connection at the rear on the base.
- 2.3.3 Before attempting any maintenance, isolate the appliance from the mains at the switch disconnecter and take steps to ensure that it is not inadvertently switched on.
- 2.3.4 We recommend supplementary electrical protection with the use of a type A residual current device (RCD).
- 2.3.5 Fixed wiring appliances incorporate a locally situated switch disconnector to connect to, which is easily accessible for switching off and safe isolation purposes. The switch disconnector must meet the specification requirements of IEC 60947.

## 2.4 FIRE SAFETY



**Appliances can present various hazards in the catering environment if not correctly used, operated, and maintained. Hazards including fire, burns from hot oil, contact with hot surfaces, fumes from boiling cleaning chemicals, eye injuries from splashes and slips from oil spillages.**

### **Operator Competency and Training**

Ensure you are trained in the safe and proper use of the appliances and know how to turn it off and switch the power off at the mains.

- 2.4.1 Ensure you are familiar with the kitchen fire safety procedures and the location and proper use of correct fire safety equipment.

### **Fire Safety Equipment**

- 2.4.2 Provide an appropriate BS compliant fire blanket, and an adequate number of fire extinguishers that comply with BS EN 3 (parts 1-6) and carry a BAFE or LPCB approval mark. At least one must be appropriate for use on electrical fires.

### **Fire Suppression System**

- 2.4.3 We recommend kitchen equipment and extraction systems are protected with a fire suppression system. Check your insurance as this may also be a condition of your policy.

2.4.4 Protect cooking and extraction equipment (including any associated extraction ductwork and hoods inside the building) by having an extinguishing system installed, in line with (or the equivalent of) [LPS 1223](#). The system should include a local alarm, automatic activation by a detection system and manual activation – located a safe distance away from the cooking equipment, preferably by a fire escape route door.

### **Operational Safety**

2.4.5 Do not leave appliances unattended when powered on or when in use.

2.4.6 Always switch the appliances off when not in use.

### **Cleaning**

2.4.7 Ensure appliances are regularly cleaned. Appliance must be serviced and maintained by a qualified and competent service provider, and there is enough room around the appliance to do so.

2.4.8 Ensure that the appliance, surrounding work area and extraction system are regularly cleaned, (at least weekly) to avoid the build-up of fats oils and greases that could present a fire risk.

2.4.9 A deep clean of the appliance should be undertaken at least every 6 months by a specialist contractor.

### **Electrical Isolation Points**

2.4.10 Ensure any separate electric switches provided for cooking equipment and/or extractor fans are accessible and clearly labelled.

### **Thermal and Operational Safety Devices**

2.4.11 Appliances are fitted with a thermal safety device. This will stop heating of the oven if it becomes overheated. This appliance will always fail safe so long as there is no damage to the thermal safety device.

## **2.5 MAINTENANCE SAFETY**



2.5.1 Unless otherwise stated, parts which have been protected by the manufacturer must not be adjusted by the installer or end user.



2.5.2 Before any cleaning is undertaken, isolate appliance from mains power supply at isolator switch.

2.5.3 Suitable protective clothing must be worn when cleaning this appliance.

2.5.4 The appliance must not be cleaned with a jet of water or steam cleaned. Do not use acid or halogen-based (e.g., chlorine) descaling liquids, flammable liquids, cleaning aids or cleaning powders.

2.5.5 Failure due to lack of proper cleaning is not covered by warranty.



2.5.6 Take care when cleaning not to dislodge or damage thermostat sensors mounted on the base and side of the pan.



2.5.7 If the glass-ceramic hob surface is cracked, smashed or damaged, switch off immediately. Do not use the appliance. Contact Falcon or your approved service provider to undertake the necessary repairs.

2.5.8 To obtain maximum performance from this unit regular servicing of the appliance should be undertaken to ensure correct operation, it is functioning as intended, and safe to use. We recommend servicing in accordance with SFG20 Maintenance Schedules and as a minimum, after 2,500 hours of use, or annually, whichever comes first and that a maintenance contract be arranged with an appointed service contact. Visits may then be made at agreed intervals to carry out adjustments and repairs.



2.5.9 During servicing of the appliance, please check the glass-ceramic hob seal. If the integrity of the seal is compromised, it must be repaired as soon as possible.

### 3.0 APPLIANCE INFORMATION

The data plate shows model information including relevant UKCA/CE-mark certification reference based on compliance with the Product Safety and Metrology Regulations/GAR, and/or Electrical Safety (LVD) and Electromagnetic Compatibility (EMC) Regulations/Directives for the Countries as stated.

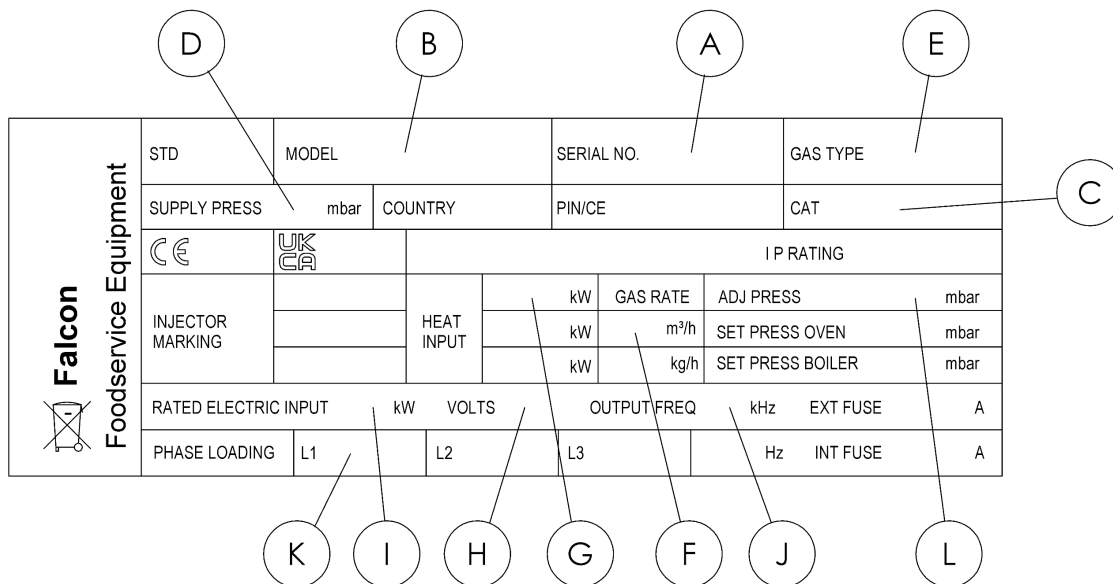

- A** - Serial No
- B** - Model No
- C** - Gas Category
- D** - Gas Supply Pressure
- E** - Gas Type
- F** - Gas Rate
- G** - Total Heat Input (Gas)
- H** - Electrical Supply Voltage
- I** - Total Electrical Power
- J** - Magnetic Field Frequency (e.g. induction units or digital communication)
- K** - Electrical Phase Loading
- L** - Gas Burner Adjustment Pressure

## 4.0 OPERATION

### 4.1 COMPONENT PARTS & CONTROLS

#### 4.1.1 E3196

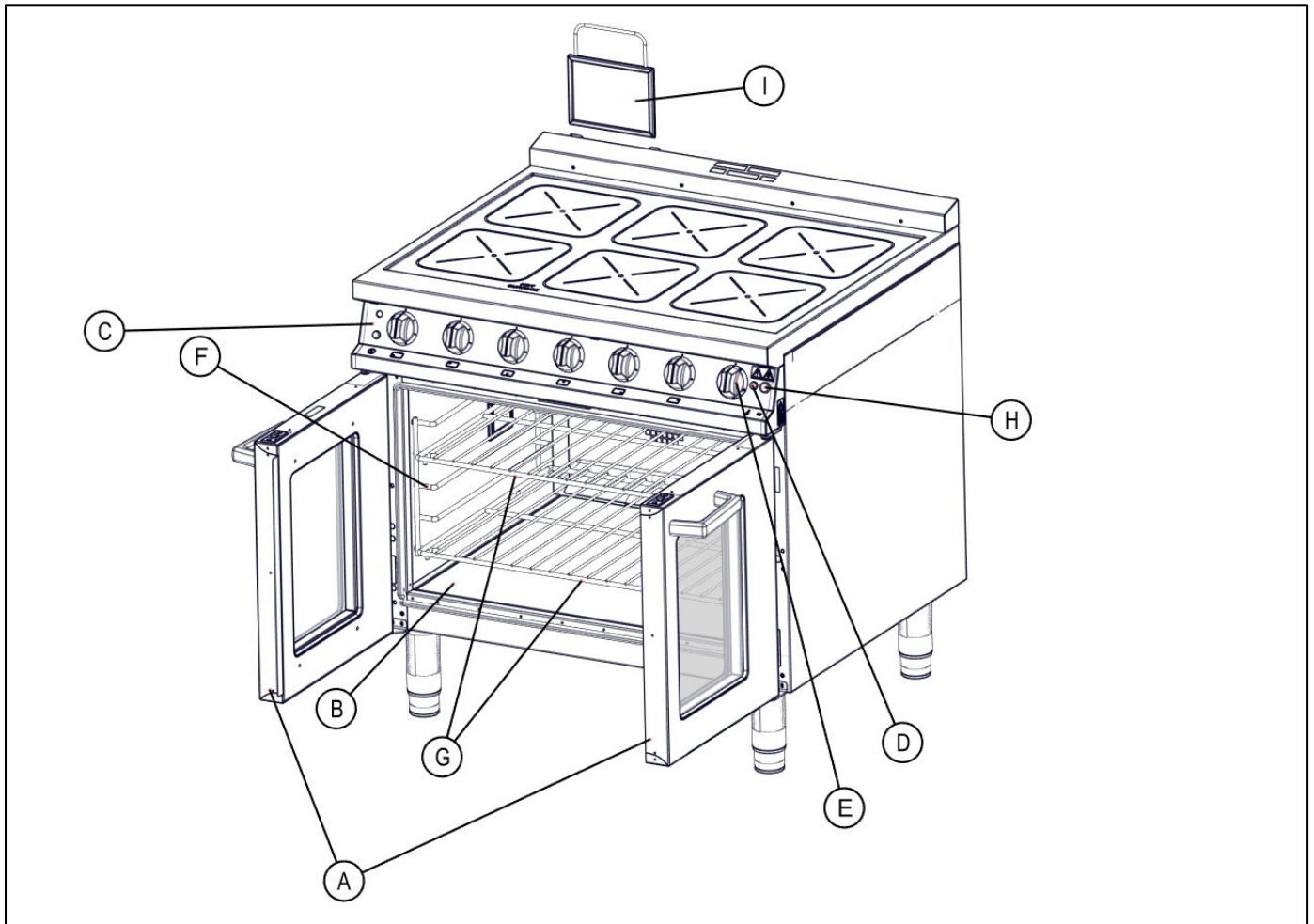

A - Left & Right Hand Door

B - Drip Tray

C - Control Panel

D - Oven Heat Neon (Amber)

E - Oven Temperature Control

F - Oven Shelf Support

G - Oven Shelf

H - Oven Light Switch

I - Air Filter

#### 4.1.2 E3164

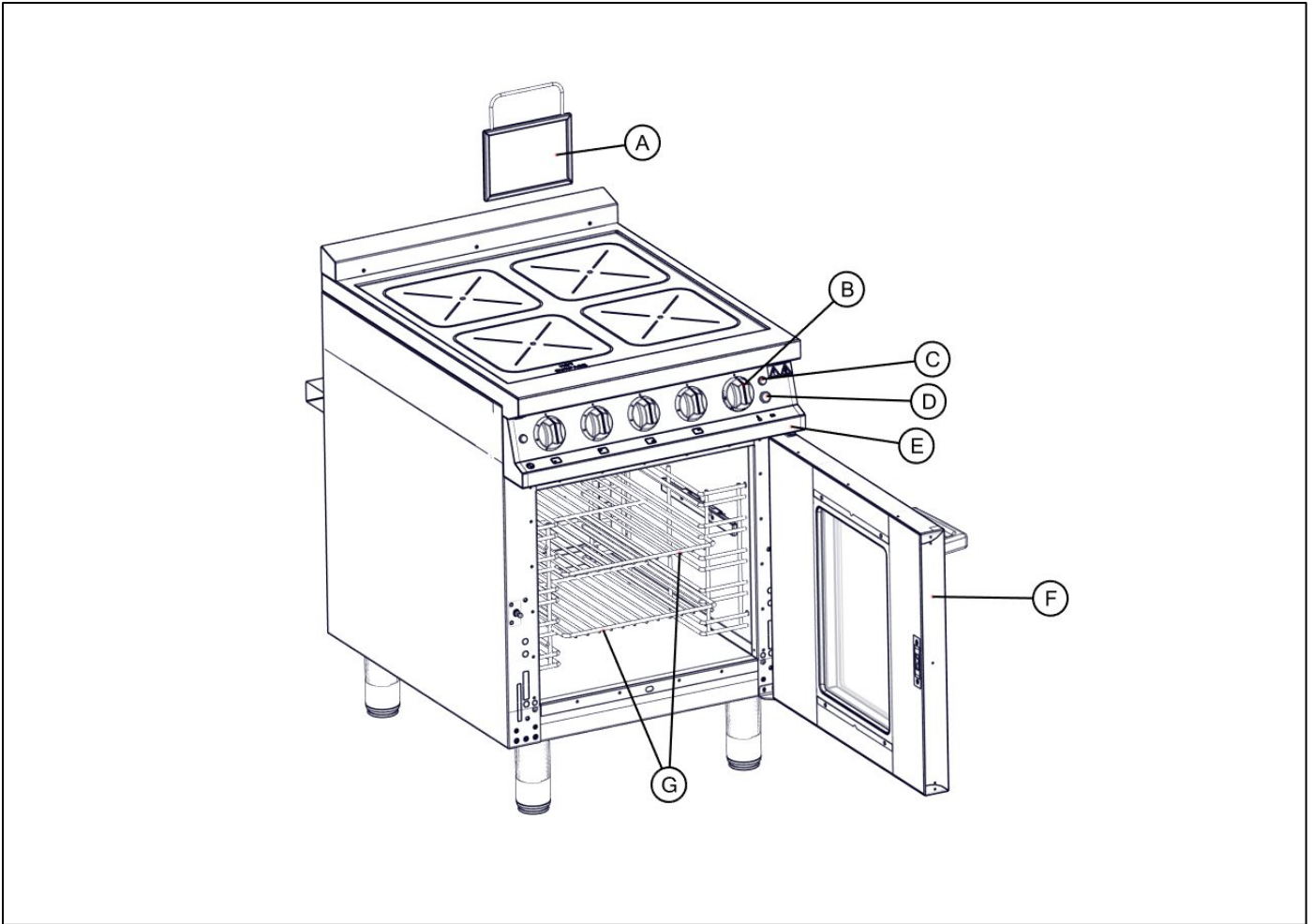

- A - Air Filter
- B - Oven Temperature Control
- C - Oven Heat Neon (Amber)
- D - Oven Light Switch
- E - Control Panel
- F - Door
- G - Oven Shelf

## 4.2 USING THE APPLIANCE – HOB

4.2.1 **\*\*WARNING – IF THE GLASS-CERAMIC SURFACE IS CRACKED, DAMAGED OR BROKEN, DO NOT USE \ SWITCH OFF APPLIANCE AND ISOLATE FROM MAINS POWER. CONTACT YOUR SERVICE AGENT\*\***

4.2.2 **\*\*WARNING – THE GLASS-CERAMIC SURFACE IS EXTREMELY HOT DURING & AFTER USE\*\***

4.2.3 Ensure the glass-ceramic hob surface is clean & free from any food debris & utensils before use.

4.2.4 Rotate the required cook-zone control knob to the desired position 1 - 6.

4.2.5 The cook-zone will glow under the glass-ceramic hob.

4.2.6 Place pot\pan on the cook-zone and begin cooking.

4.2.7 The cook-zone will cycle on & off to maintain the desired heat output during operation. The on & off time will vary depending on the control position, 1 – 6.

4.2.8 During operation, the “Hot Surface”  indicator will illuminate and cooling fans will switch on.

4.2.9 The “Hot Surface” indicator will stay illuminated and cooling fans will operate for at least 30 minutes after any or all cook-zone controls are switched off, until the glass-ceramic hob surface temperature reduces to a safe level.

## 4.3 USING THE APPLIANCE – OVEN



**TO AVOID SCALDING, DO NOT USE LOADED CONTAINERS WITH LIQUIDS OR FOOD THAT BECOMES FLUID AFTER COOKING ABOVE A HEIGHT FOR WHICH THE CONTENTS CAN EASILY BE VIEWED**

4.3.1 Rotate the oven control knob to the desired temperature, the amber neon will illuminate.

4.3.2 Once the oven has reached temperature, the amber neon will switch off. Loading can commence.

4.3.3 Load oven quickly to minimise heat loss.

4.3.4 The temperature and amount of food loaded will affect the optimum temperature setting and cook times.

4.3.5 Overloading will adversely affect cooking performance.



**NOTE:** The oven is fitted with a thermal safety device. This will prevent the oven from overheating. The oven will not operate if the thermal safety device has activated. If the thermal safety device has activated, contact a suitably qualified service engineer. The reason for overheating must be identified & resolved before returning the appliance to service.

## 5.0 CLEANING

---



**BEFORE CLEANING, ISOLATE THE APPLIANCE AT THE MAIN SWITCH AND TAKE STEPS TO ENSURE THAT IT IS NOT INADVERTENTLY SWITCHED ON. SUITABLE PROTECTIVE CLOTHING MUST BE WORN WHEN CLEANING THIS APPLIANCE.**



**THE APPLIANCE MUST NOT BE STEAM CLEANED OR CLEANED WITH A WATER JET. DO NOT USE ACID OR HALOGEN-BASED (E.G. CHLORINE) DESCALING LIQUIDS, FLAMMABLE LIQUIDS, CLEANING AIDS OR CLEANING POWDERS. FAILURE DUE TO LACK OF PROPER CLEANING IS NOT COVERED BY WARRANTY.**

When removing heavy items to aid cleaning or maintenance particular care should be taken. A manual handling risk assessment is the best way to determine the level of risk to anyone using or maintaining this equipment.

For further help and information on manual handling and associated risk assessment please refer to the Health and Safety Executive website; [www.hse.gov.uk](http://www.hse.gov.uk) document ref: manual handling at work INDG143. International customers should default to the health and safety guidelines provided by your government body.

Other useful references for health and safety issues:

- [www.hse.gov.uk](http://www.hse.gov.uk)
- Essentials of health and safety at work ISBN978
- Noise at work INDG362
- Safe systems of work
- Other notes added to the body of the instructions

### 5.1 CLEANING – HOB

Cleaning must be undertaken at 3 key stages as outlined below

- Before Operation, 5.1.1
- During Operation, 5.1.2
- After Operation, 5.1.3

**Do not use abrasive, cleaning materials, accessories or chemicals (including flammable detergent chemicals) on the ceramic top, whether surface is hot or cold.**

**Best practise to preserve your ceramic top is to keep surface clean and free from debris every time when required and doing so regularly and as often as possible.**

5.1.1 Before operating the equipment ensure the following procedures are followed.

- Turn all control dials to zero.
- **Ensure the appliances has been isolated from the mains supply.**

- With a soft, or microfibre towel, wipe the ceramic surface removing any dust or foreign particles. More robust deposits can be removed by using hot soapy water solution and soft sponge scourer.

5.1.2 During operation ensure the following procedures are followed. Extra care should be taken to perform cleaning tasks.

- Spillages and food debris must be safely removed at the earliest, most convenient opportunity.
- The hob **will be hot to the touch**, extra care should be taken to avoid potential **burns, scalds and injury**
- Ensure the cleaning towel used is well dampened with warm water or warm soapy water (For additional safety oven mitts or heat resistant gloves will offer more protection to hot steam vapours when cleaning the affected surface area)
- With short, quick wipes, using dampened towel, remove spillage or food debris.

**Do not use cold water, ice or cold dampened towels, which will increase risk of scalding and damaging the ceramic top.**

**Do not leave towels, cloths or other items, on the ceramic surface, it can catch fire due to hot surface areas.**

5.1.3 After Operation ensure the following procedures are followed.

- Remove all pots and pans from glass top.
- Allow the glass top to cool for at least 30mins or until warm and safe to touch.
- Turn all dials to zero and **ensure the appliances has been isolated from the mains supply.**
- Prepare a solution of warm to hot soapy water, dampen a microfibre towel and then apply damp towel to the ceramic surface. Repeat as often as required.
- For more robust deposits, a soft sponge scourer may be used.
- For heavier and stubborn deposits, the ceramic scraper provided, may be used. Care should be taken when using the scraper, ensuring sufficient blade setting and only applying scraping pressure to those affected areas. Tip – use up and down short movements, holding the scraper at a 20° - 30° angle, front to back.

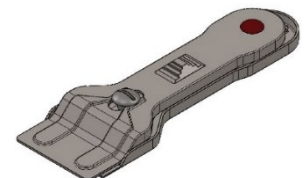

**Do not use strong chemicals under any circumstances on the ceramic surface, including any abrasive, corrosive, flammable detergents.**

Consult your chemical, COSHH supplier to advise on commercially graded and safe ceramic hob polishes, to assist in the presentation, preservation of the ceramic tops.

## 5.2 CLEANING - OVEN

**NOTE:** All surfaces are easier to clean if spillages are removed before becoming burnt on, and the appliance is cleaned daily and as often as possible and required.

It should be noted that certain scouring pads including nylon types can easily mark stainless steel. Care should be exercised during cleaning process. When rubbing stainless steel with a cloth, always rub in the direction of the grain.

**NOTE:** Do not use any abrasive or corrosive chemicals or detergents on any of the surfaces.

5.2.1 Switch off appliance and cool down.

5.2.2 Remove shelves and both oven shelf supports.

5.2.3 Soak these in a sink filled with hot soapy water.

5.2.4 Clean oven chamber with a mild cleaning detergent & sponge, microfibre cloth.

5.2.5 Use a scouring pad to scrub components being soaked in sink.

5.2.6 Rinse parts thoroughly after scrubbing and dry.

5.2.7 Replace shelf supports and shelves within oven cavity.

5.2.8 Clean door glass surfaces with a mild cleaning detergent & sponge or microfibre cloth. Wipe dry.

**Under no circumstances should an abrasive scourer or detergent be used on the glass surface of the door, inside or outside.**

5.2.9 See [www.falconfoodservice.com/info-centre/falcon-tv/cleaning-guides/cleaning-guides-ovens-and-hobs](http://www.falconfoodservice.com/info-centre/falcon-tv/cleaning-guides/cleaning-guides-ovens-and-hobs) for a detailed instructional guide & video.



## 5.3 CULINARY GUIDANCE

### 5.3.1 Glass Hob

8 out of 12 cookery methods can be used when cooking on the hob.

- Sauté, pan fry or shallow fry
- Boil
- Simmer
- Steam
- Poaching
- Braising or stewing
- Pot roasting

For best cooking results, use good quality, undamaged pots and pans that have flat, un-warped bases.

Using undamaged cookware will also minimize the opportunity of accidental damage to ceramic hobs.

Tri-wall stainless steels pots and pans are good, however, most cookware are suitable to use on ceramic.

Always check cookware manufacturer guidelines and information.

Take extra care with cast iron and or heavy bottomed cookware.

Heat transfer is by means radiation and conduction. Take care when lifting and moving cookware.

Good practise – heavy laden cookware – carefully lift and move position rather than dragging and or pushing across the ceramic surface – a further operator measure to protect the ceramic.

Never leave equipment unattended during cooking or in use.

Heat up times may differ from equipment worked on before, therefore, it is always advisable to understand the performance and apply changes to cooking times, if and where needed. However, cooking techniques will remain the same.

Due to fast heating up times and good heat retention, there is no need to leave the zones charged without cooking taking place.

As a result of good heat retention, always remove cookware from zones after tasks had been carried out.

Do not store heavy items over or above the ceramic hob.

### 5.3.2 Fan Assisted Oven

Once pre-heated, allow for a further 15 minutes to charge the full chamber and metals inside.

Good tip, pre-heat the oven 10 - 15°C higher than set temperature, load, then turn dial down to desired cook, roast or bake temperature.

For heavier loads or for deep chilled items or large joints, increase pre-heat temperature by up to a further 10-15°C max. Thus 30°C higher than actual cook temperature. Turn to cook temperature after loading.

Simultaneous 2 shelf cooking permitted.

Shelf positions 2 and 4 are recommended for best results.

Landscape loading – 2/1 GN or 2x 1/1 GN compatible per shelf, on the oven grid.

Oven grids must be in place to accommodate oven trays.

For best cooking results, use oven light to check on cooking progress and to avoid opening the oven doors during cooking.

Always open right door first, followed by left hand door, ensuring that doors are completely open when loading and unloading.

If door closure tension becomes weak, tighten the spring ball door catches by means of a suitable coin and turning it anti-clockwise till correct tension, and clockwise if adjustment required.

Reminder – convection ovens have different cooking abilities than combination ovens and or static non-fan-assisted ovens, and will therefore require, where and if needed, slight changes to cooking times and temperature settings

## 6.0 SPECIFICATION

---

### 6.1 APPLIANCE WEIGHT TABLE

APPLIANCE	UNIT WEIGHT (kg)	PACKED WEIGHT (kg)
E3196	115 kg	130 kg
E3164	85 kg	100 kg

### 6.2 TECHNICAL DATA TABLE

E3196	CURRENT			POWER
PHASE	MIN (A)	MAX (A)	ACTUAL (A) @ 230V	(kW) @ 230V
L1	26.6	31.1	29.6	6.8
L2	27	31.5	30	6.9
L3	27	31.5	30	6.9
E3164	CURRENT			POWER
PHASE	MIN (A)	MAX (A)	ACTUAL (A) @ 230V	(kW) @ 230V
L1	12.6	14.7	14	3.2
L2	18	21	20	4.6
L3	18	21	20	4.6

# 7.0 DIMENSIONS / CONNECTION LOCATIONS

## E3196

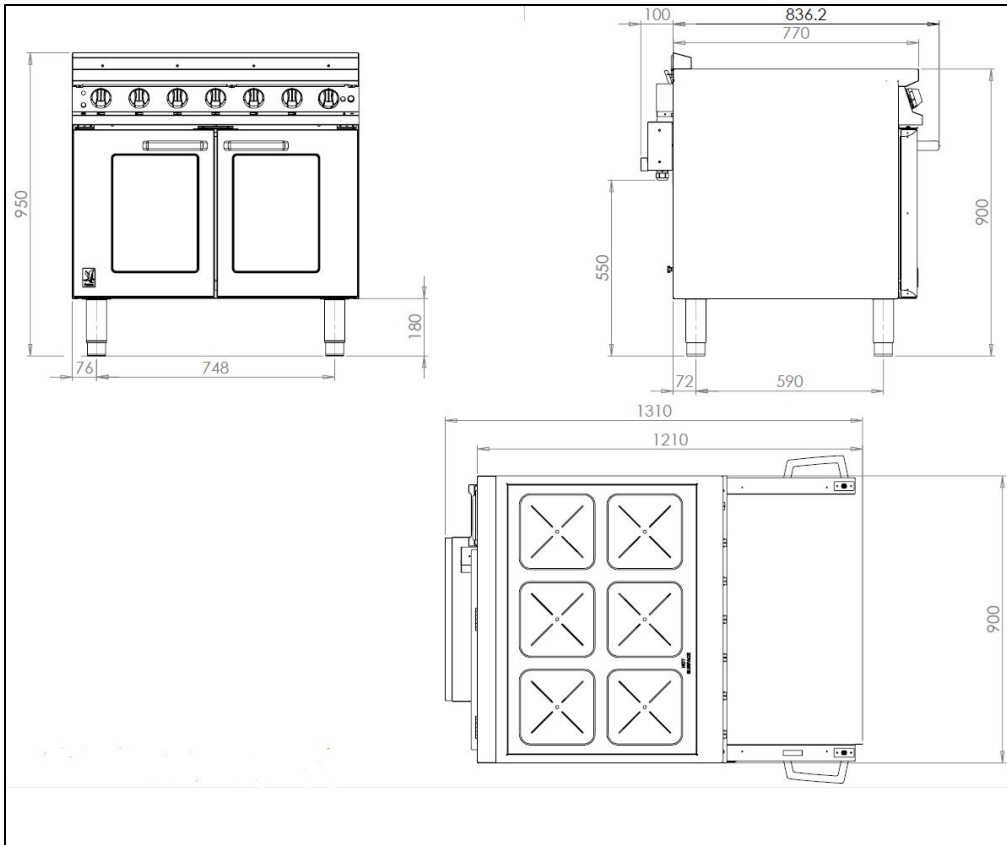

## E3164

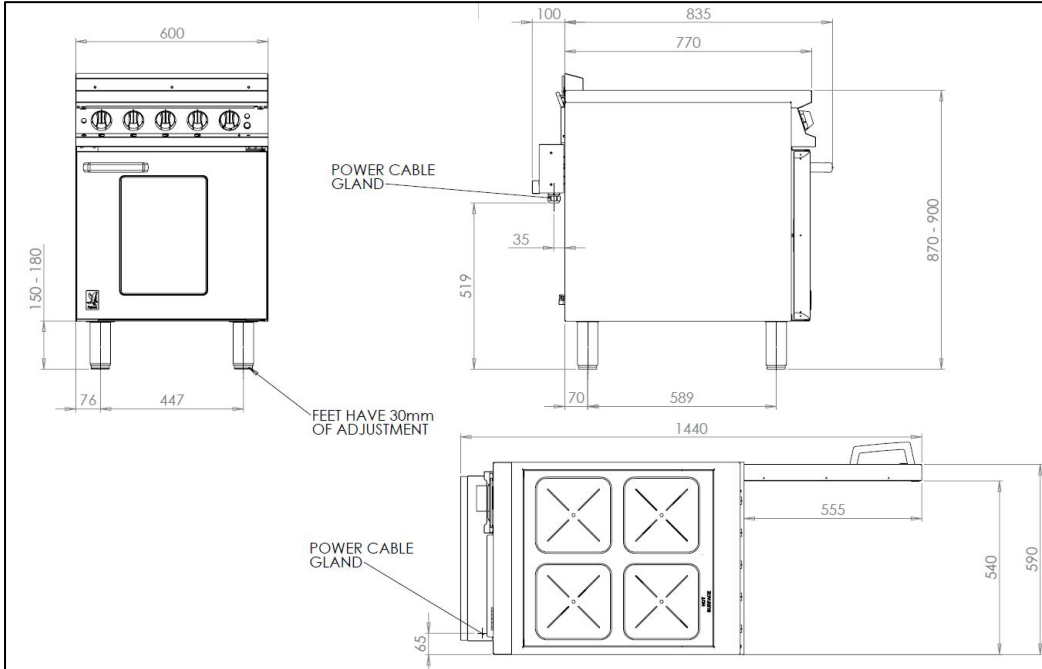

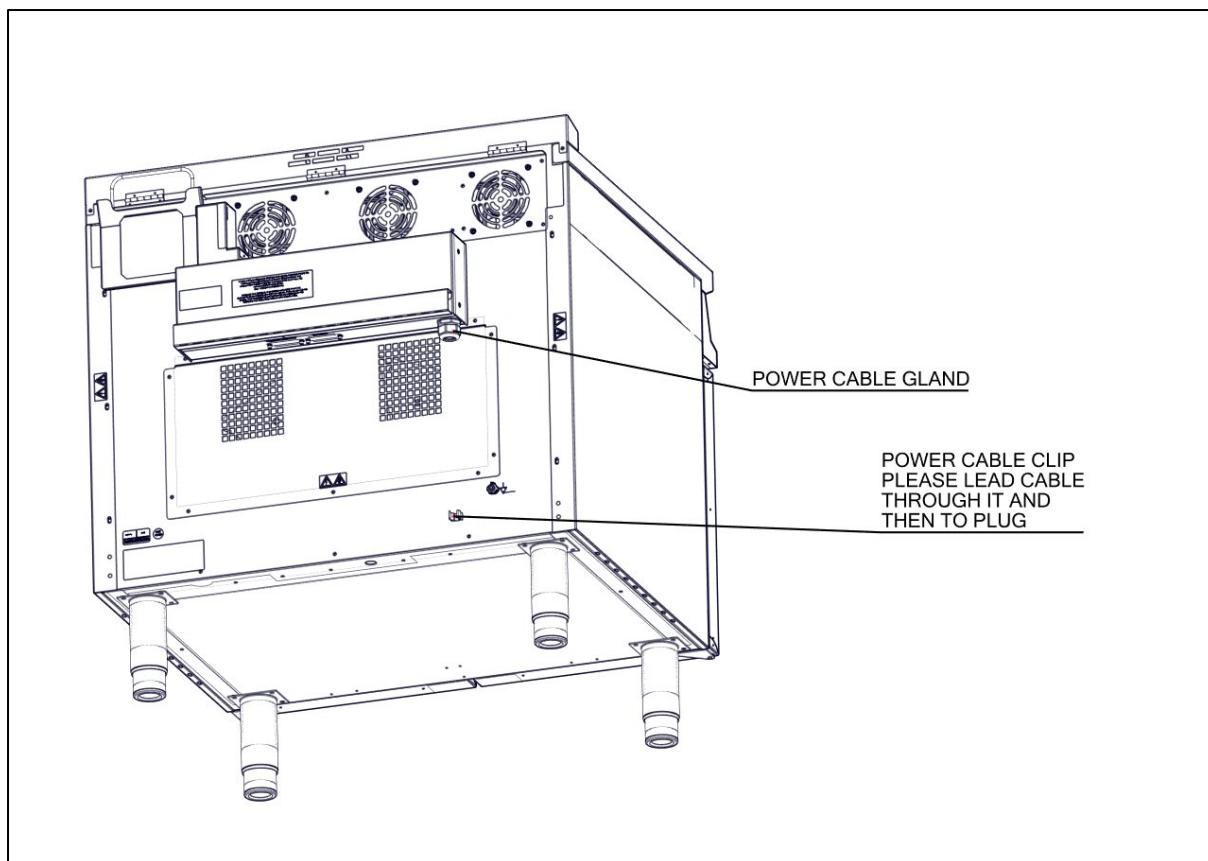

Feed power cable through the cable clip for both E3164 and E3196 to avoid cable contact with vented hot air.

## 8.0 INSTALLATION

---

### 8.1 SITING / CLEARANCES

Cooling system vents are situated at the rear of the appliance. Consideration must be given to clearances from wall at the rear of the appliance (150mm) and overlying surfaces and structures to allow steam generating from cooking process to be fully ventilated.

Clearance at rear must be at least 150mm, for both the E3196 and E3164, to ensure sufficient area for cooling & ventilation

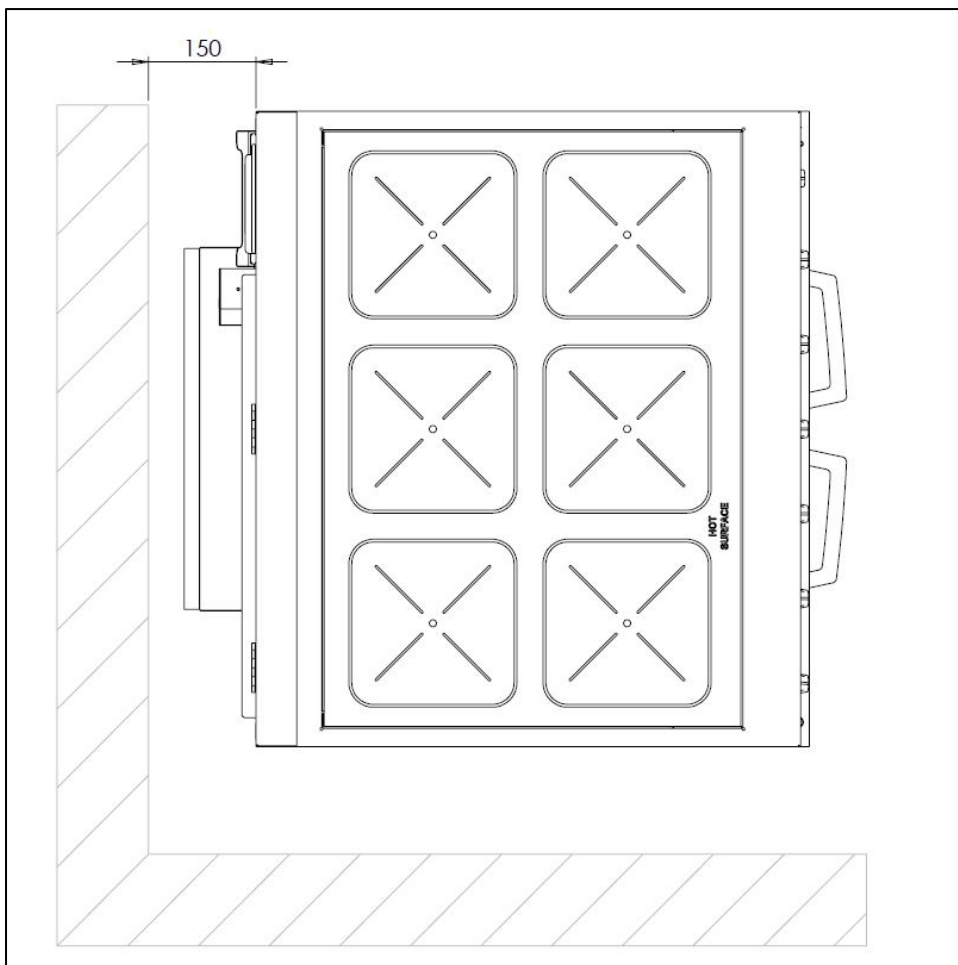

**IF SUITING, THE NECESSARY CLEARANCES TO ANY COMBUSTIBLE WALL MUST BE THE LARGEST FIGURE GIVEN FOR INDIVIDUAL APPLIANCE INSTRUCTIONS.**

Consideration must also be given to the practicalities of being able to fully open the oven doors for loading and removing food on cooking trays and wire racks.

It must be easy to isolate the appliance from the electrical supply before starting cleaning and maintenance procedures

## 8.2 ASSEMBLY

8.2.1 Position the appliance and level using feet adjusters as shown below.

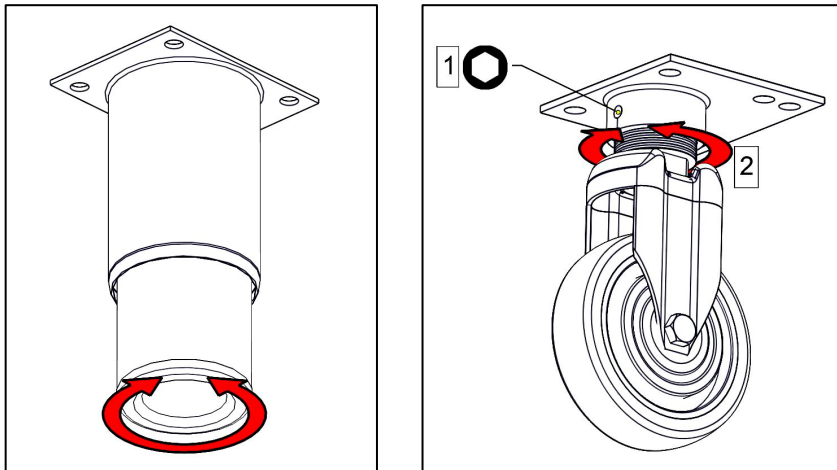

## 8.3 ELECTRIC SUPPLY & CONNECTION

### Electrical Safety and Advice Regarding Supplementary Electrical Protection

Commercial kitchens and foodservice areas are environments where electrical appliances may be located close to liquids or operate in and around damp conditions or where restricted movement for installation and service is evident.

The installation and periodic inspection of the appliance should only be undertaken by a qualified, skilled, and competent electrician; and connected to the correct power supply suitable for the load as stipulated by the appliance data label.

The electrical installation and connections should meet the necessary requirements to the local electrical wiring regulations and any electrical safety guidelines.

#### We recommend: -

- Supplementary electrical protection with the use of a type A residual current device (RCD)
- Fixed wiring appliances incorporate a locally situated switch disconnector to connect to, which is easily accessible for switching off and safe isolation purposes. The switch disconnector must meet the specification requirements of IEC 60947.

#### Your attention is drawn to: -

#### 18<sup>th</sup> IET Wiring Regulations BS 7671:2018 – Guidance Note 8 - 8.13: Other locations of increased risk

*It is recognized that there may be locations of increased risk of electric shock other than those specifically addressed in Part 7 of BS 7671. Examples of such locations could include laundries where there are washing and drying machines in close proximity and water is present, and commercial kitchens with stainless steel units, where once again, water is present.*

*Where because of the perception of additional risks being likely, the installation designer decides that an installation or location warrants further protective measures, the options available include:*

- *Automatic Disconnection of Supply (ADS) by means of a residual current device having a residual operating current not exceeding 30mA.*
- *Supplementary protective equipotential bonding; and*
- *Reduction of maximum fault clearance time.*

*The provision of RCDs and supplementary bonding must be specified by the host organization's appointed installation designer or electrical contractor and installed by a suitably qualified and competent electrician so as to comply with Regulations 419.2 and 544.2.*



## **THIS APPLIANCE MUST BE EARTHED**

This appliance is provided with a terminal for connection of an external equipotential conductor. This terminal is in effective electrical contact with all fixed exposed metal parts of the appliance and allows the connection of conductor having a nominal cross-section area of up to 10mm<sup>2</sup>. It is located at the rear of the unit and identified by the following label. It must only be used for equipotential bonding purposes.



The location of the electrical inlet is at the rear right hand lower corner of electrical terminal box as shown in section 6.3, page 24. This unit is suitable for AC supplies only. The standard terminal arrangement is three - phase (230V~) for all variants.

Live 1 (Phase 1)	Brown
Live 2 (Phase 2)	Black
Live 3 (Phase 3)	Grey
Neutral	Blue
Earth	Yellow/Green

To attach the mains cable, remove rear access panel as shown in section 6.3, page 24.

The outer sheathing must be stripped 150mm from cable end. Pass mains cable through cord gland and ensure conductors are terminated with M5 ring crimps.

Route the mains cable as shown on page 18 & attach to the terminal block.

## 8.4 COMMISSIONING

8.4.1 Place a suitable thermocouple in the centre of the oven.

8.4.2 Turn on mains power supply ON, ensure red neon illuminates.

8.4.3 Turn oven temperature control to 200°C, ensure amber neon illuminates.

8.4.4 Let the oven heat up. When amber neon switches off, check the temperature is 200°C +/- 10°C.

8.4.5 Switch oven OFF.

8.4.6 Turn all hob controls to position 6.

8.4.7 Ensure all hob elements glow under the glass-ceramic hob, wait until the hob cooling fans and “hot surface” indicator switch on.

8.4.8 Switch off all hob controls and allow appliance to cool.



**PLEASE FILL OUT THE INFORMATION TABLE ON THE FRONT COVER AFTER COMMISSIONING.**

## 9.0 SERVICING

---



**BEFORE ATTEMPTING ANY MAINTENANCE, ISOLATE THE APPLIANCE AT THE MAINS SWITCH AND TAKE STEPS TO ENSURE THAT IT CANNOT BE INADVERTENTLY SWITCHED ON.**



**ANY REPLACEMENT SUPPLY CABLE MUST BE 4MM<sup>2</sup>, CORD CODE DESIGNATION 245 IEC 57 (CENELEC H05 RN-F).**

### **MAINTENANCE CHECK**

Regular servicing of the appliance should be undertaken to ensure correct operation, it is functioning as intended, and safe to use. We recommend servicing after 2,500 hours of use, or annually, whichever comes first.



Any maintenance schedule should be carried out in accordance with SFG20 Maintenance Schedule. Should any issues with the integrity of the components be identified these should be replaced. If the appliance is not considered safe the unit should be removed from service and the responsible person advised why the unit is not safe to use and what remedial action is needed. Contents of the maintenance schedule should be agreed with the maintenance provider.

## 9.1 CONTROL PANEL AND HOB ACCESS

**REMOVE AIR FILTER BEFORE LIFTING HOB ON BOTH APPLIANCES TO AVOID DAMAGE**

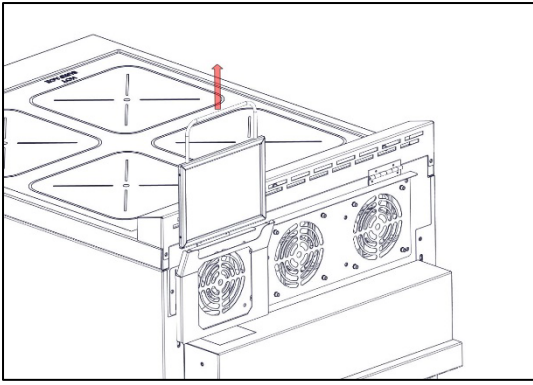

**E3196**

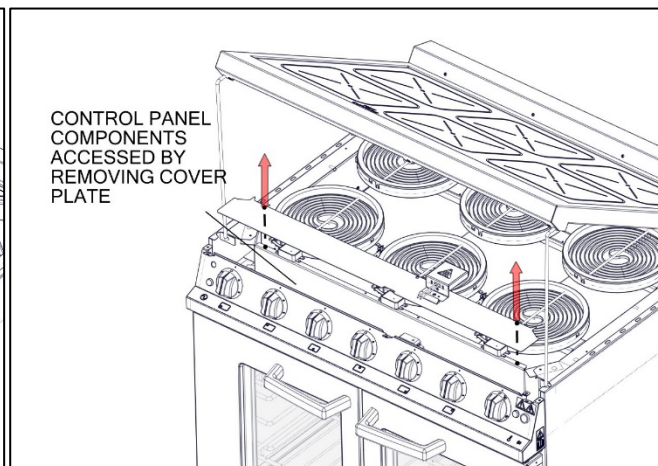
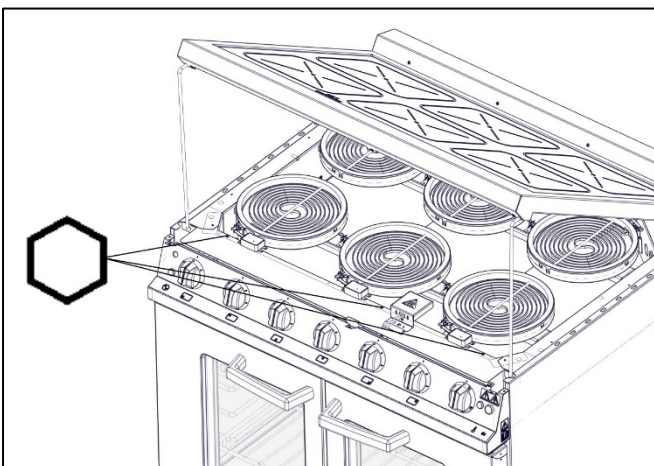
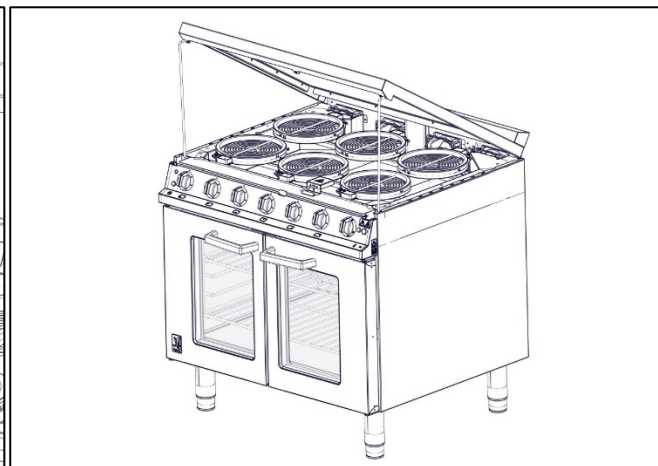
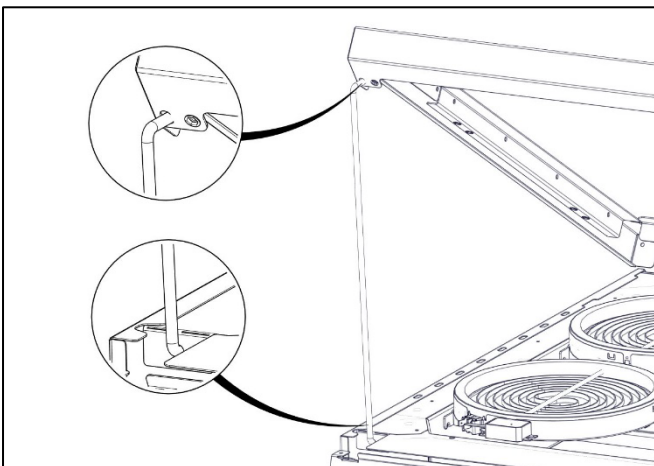
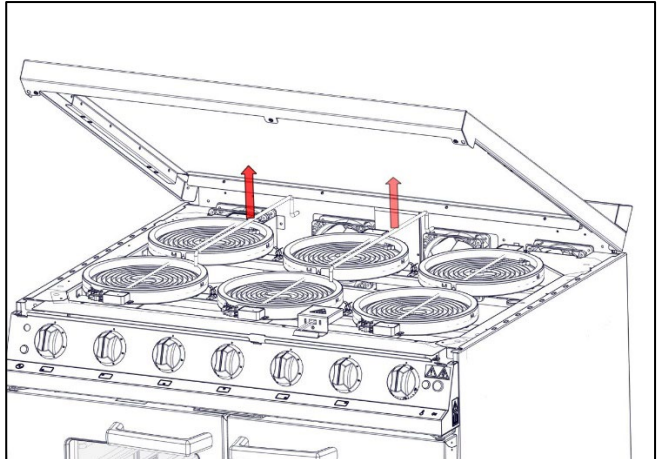
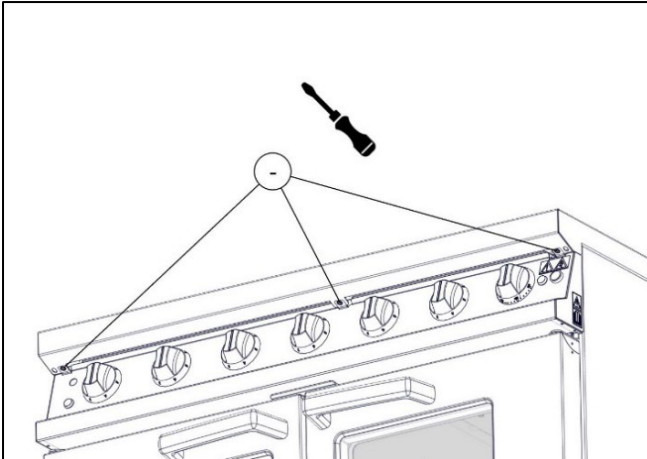

**E3164**

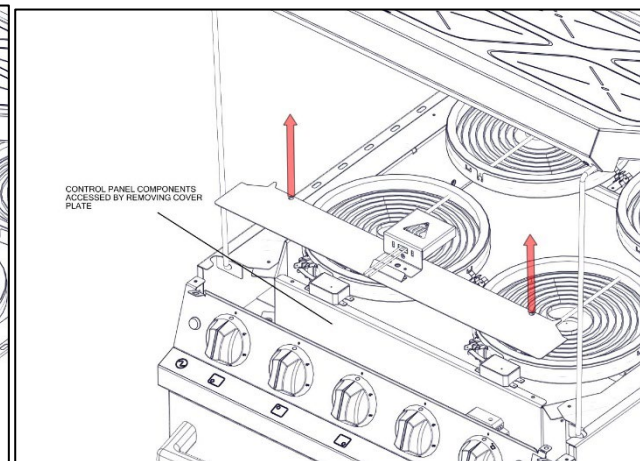
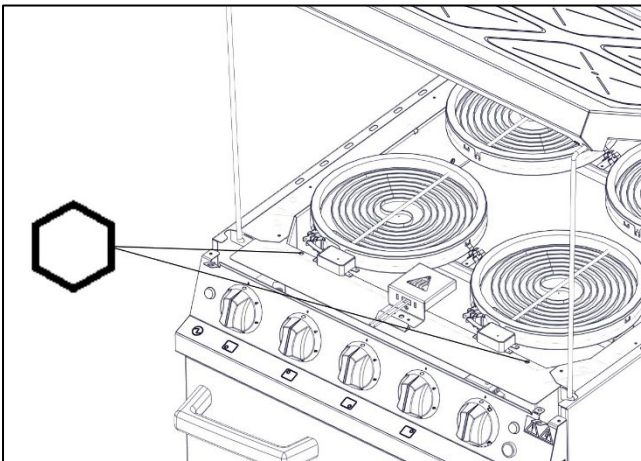
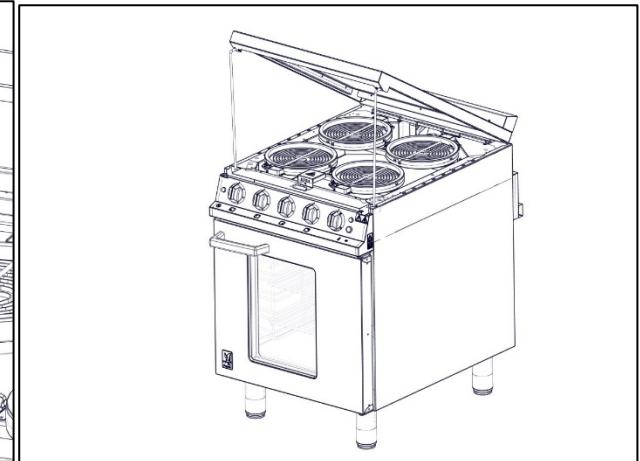
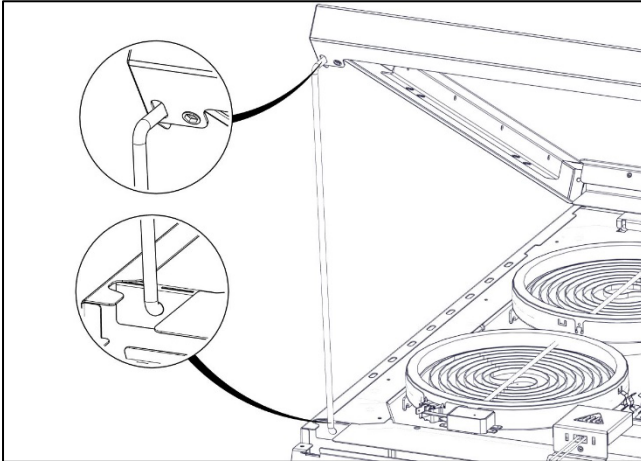
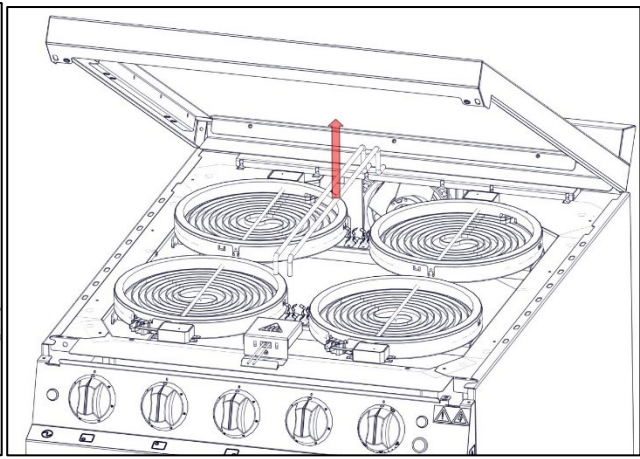
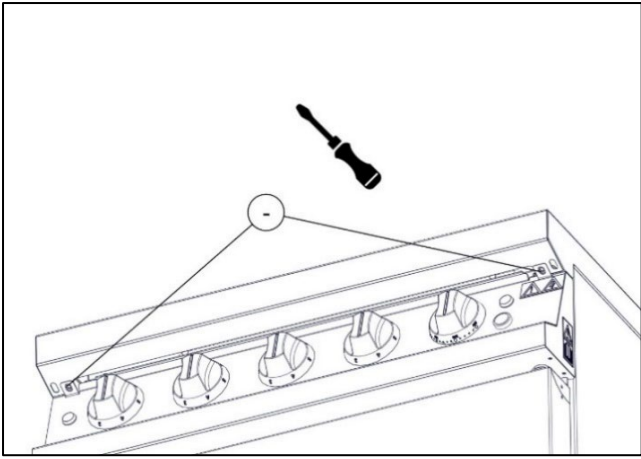

## 9.2 COOLING FAN REMOVAL

**E3196**

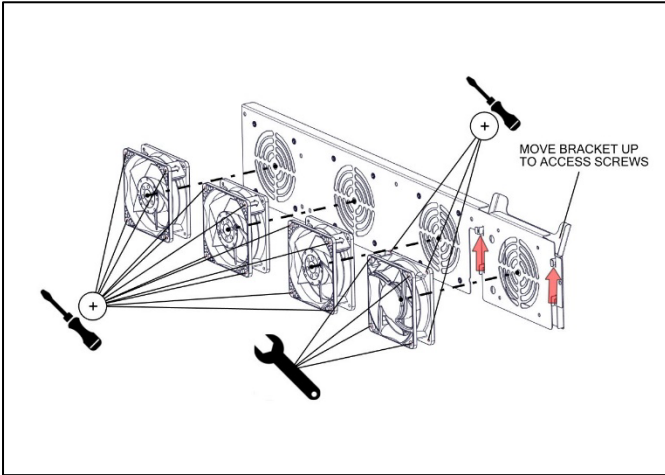
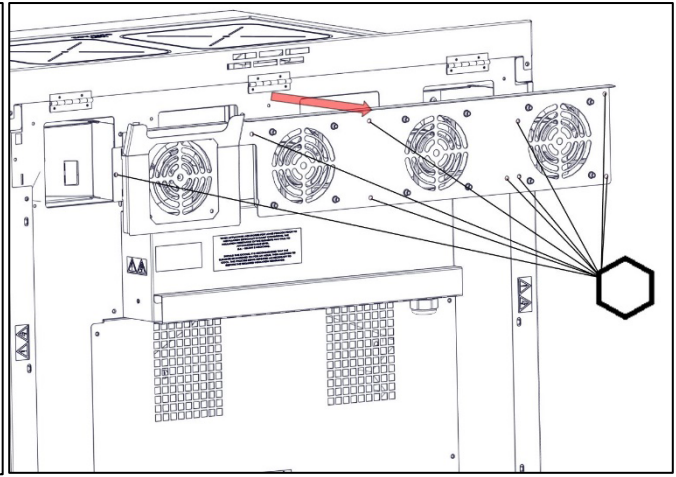
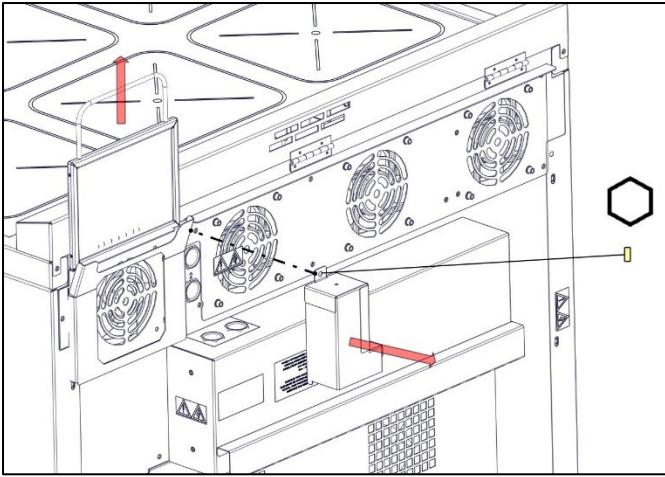

Be sure to replace the fans in the same orientation as installed. The fan on the far right of image must be positioned so it draws air into the unit (see arrow on fan body).

### **E3164**

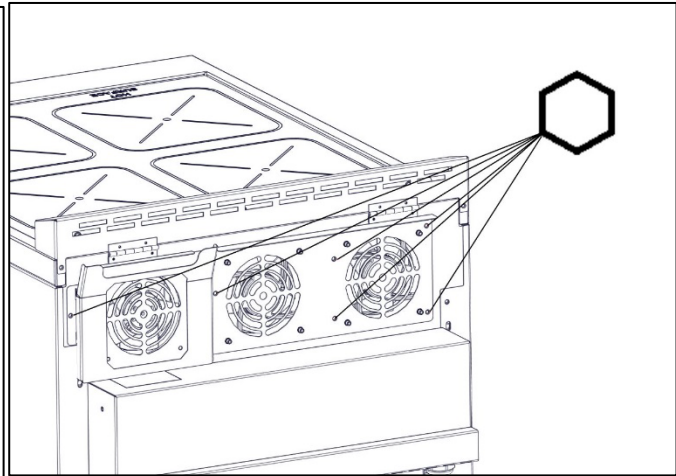
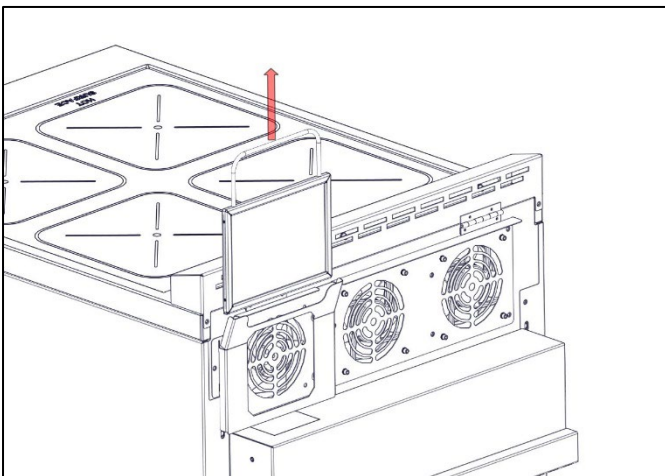

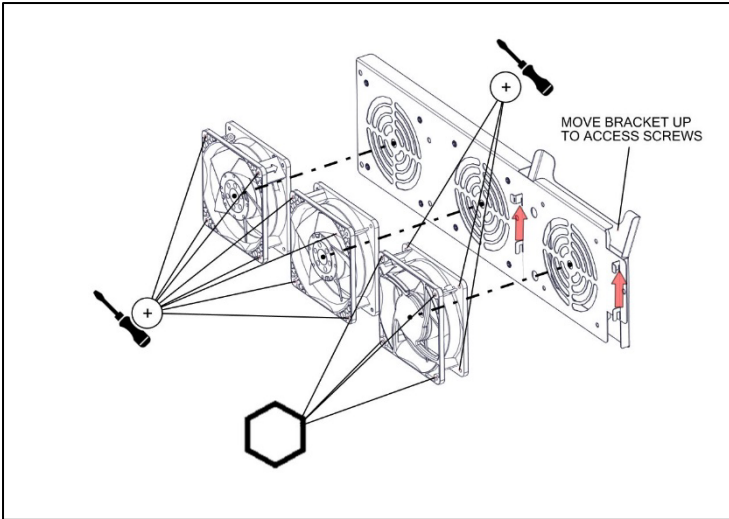

Be sure to replace the fans in the same orientation as installed. The fan on the far right of image must be positioned so it draws air into the unit (see arrow on fan body).

### 9.3 ELECTRIC BOX ACCESS

#### **E3196**

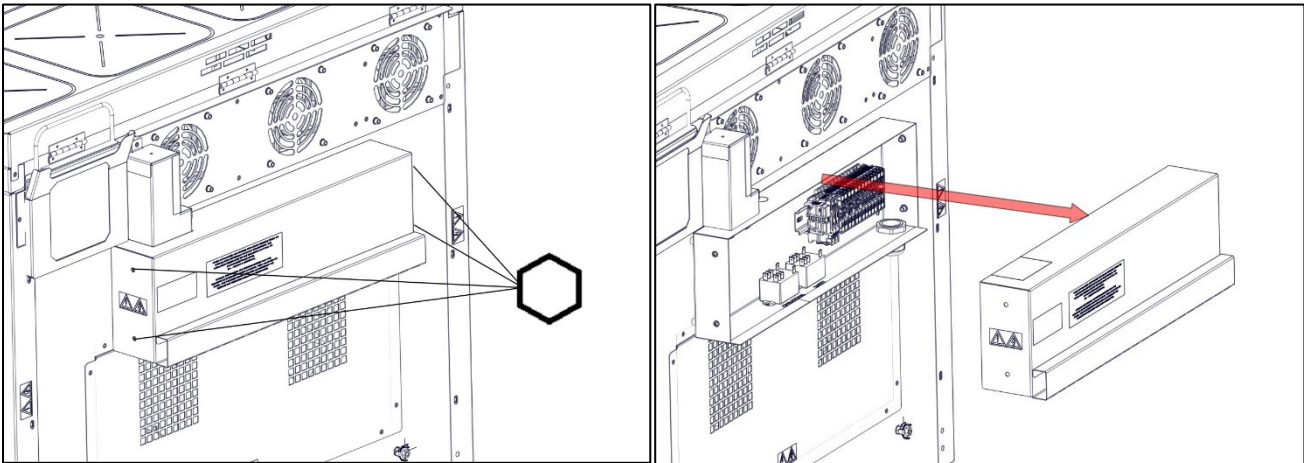

#### **E3164**

The Electric Box of the E3164 is also the Fan Cover. To remove follow steps outlined in 9.2 E3164.

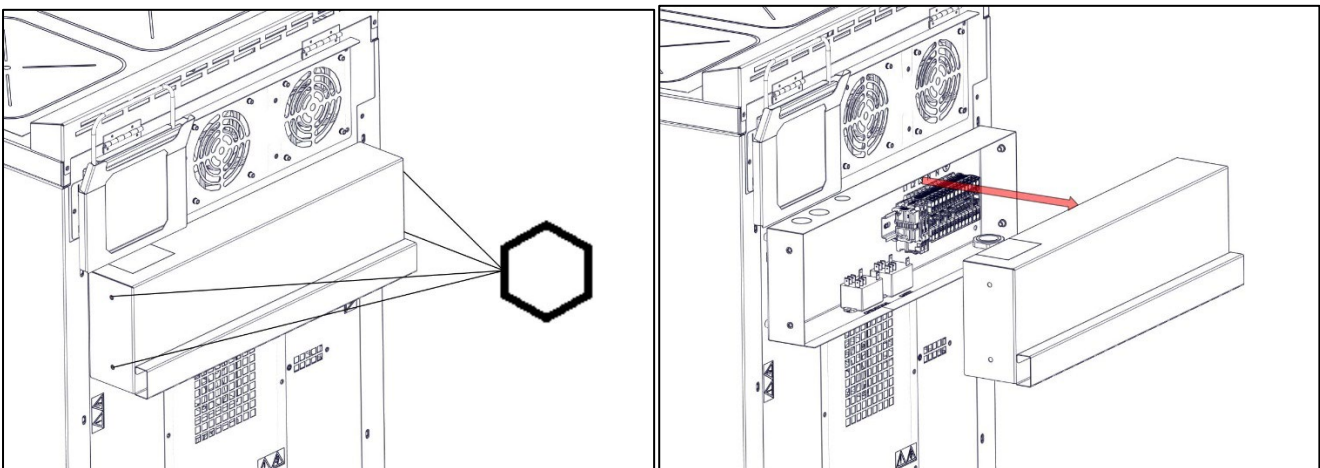

## 9.4 DOOR REMOVAL

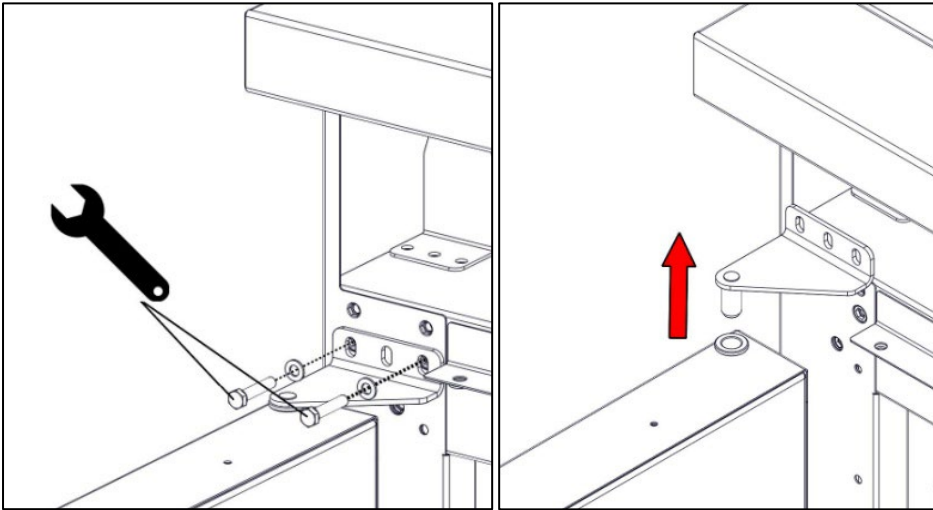

## 9.5 RELAY REMOVAL

Follow steps in 9.3 to remove Electric Box then follow instruction in image below

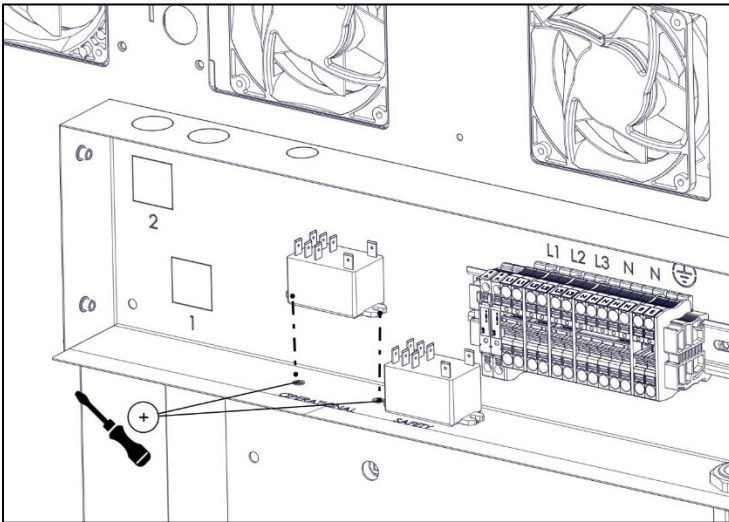

## 9.6 OVEN ELEMENTS REMOVAL

### E3196

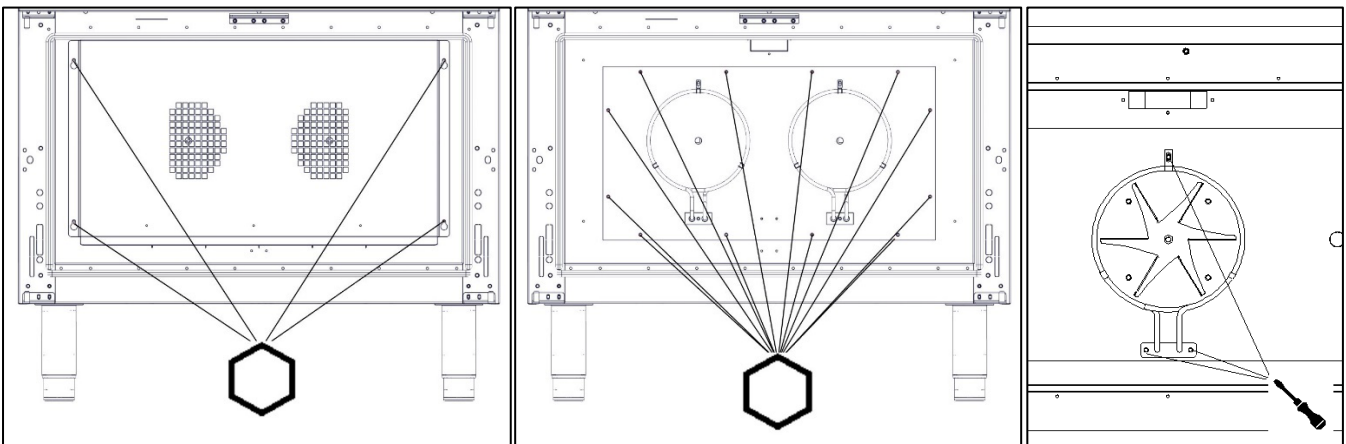

### E3164

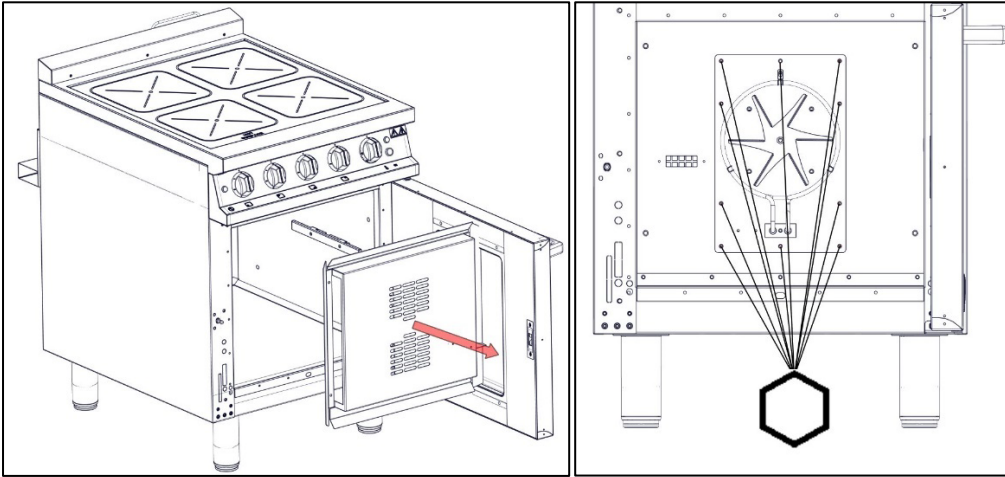
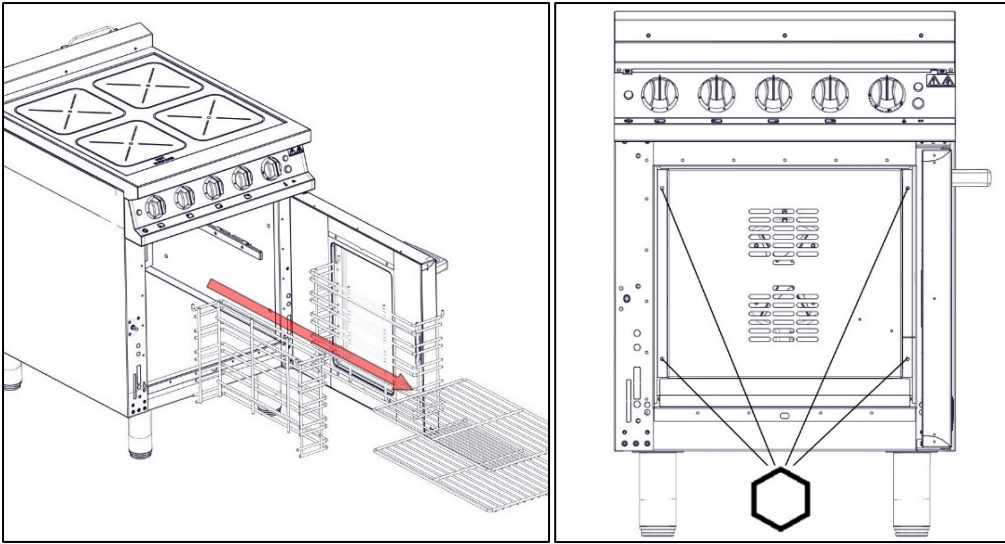

Note: The element can be removed from inside the cavity, without removing rear panel (image 1 above).  
 Remove element screws (images 2 & 3), carefully withdraw element and disconnect wires.

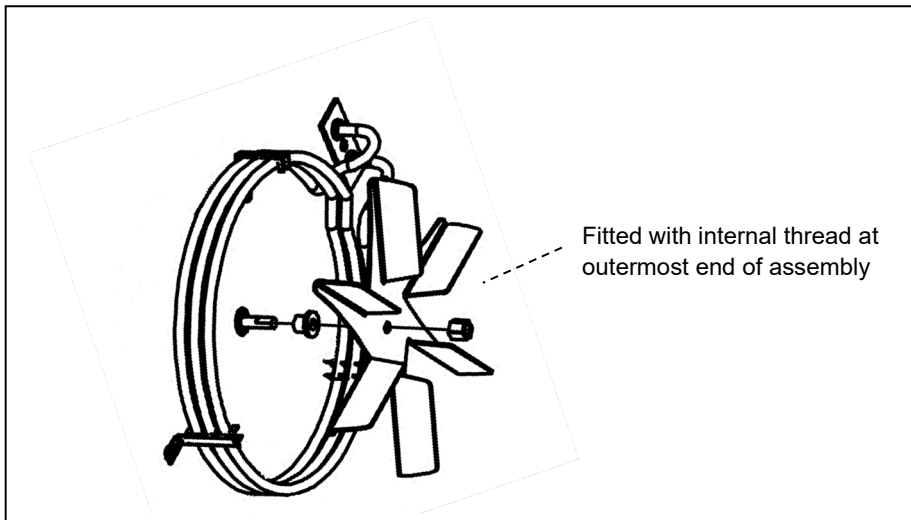

## 9.7 HOB ELEMENTS REMOVAL

### E3196

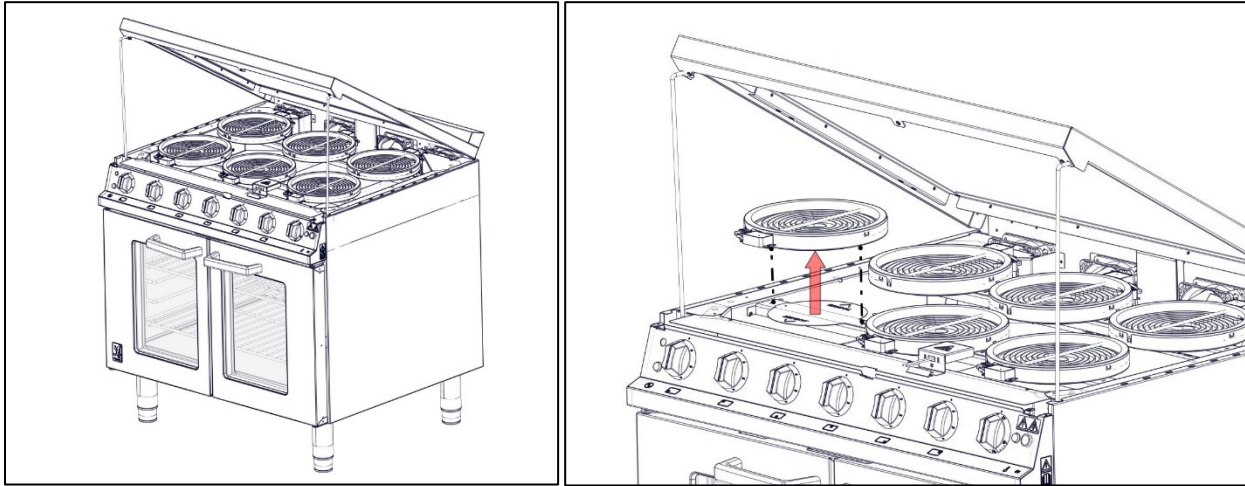

### E3164

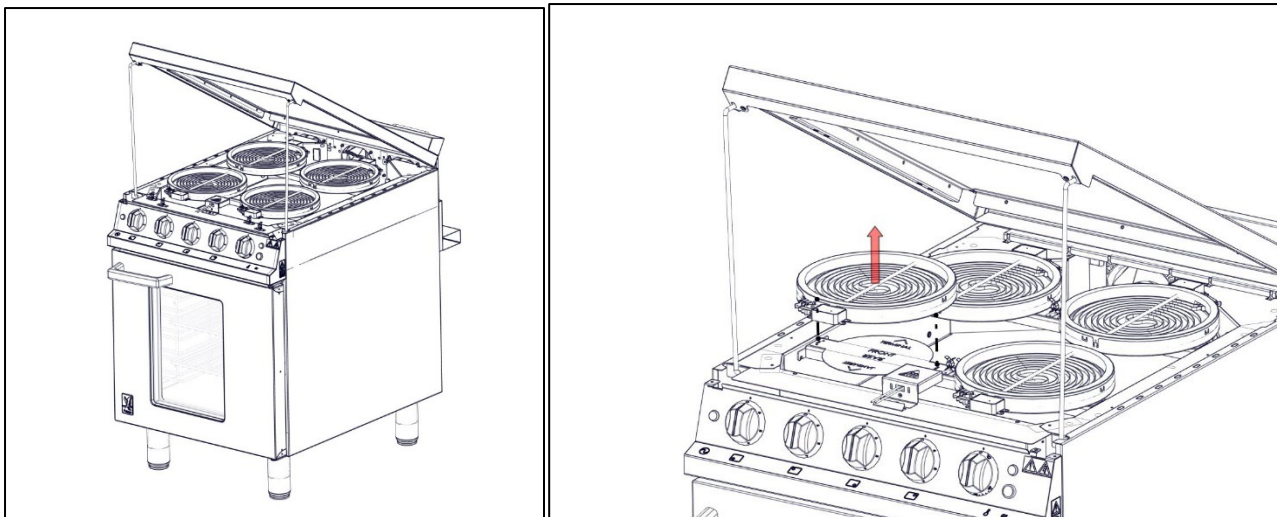

## 9.8 OPERATING THERMOSTAT REMOVAL

### E3196

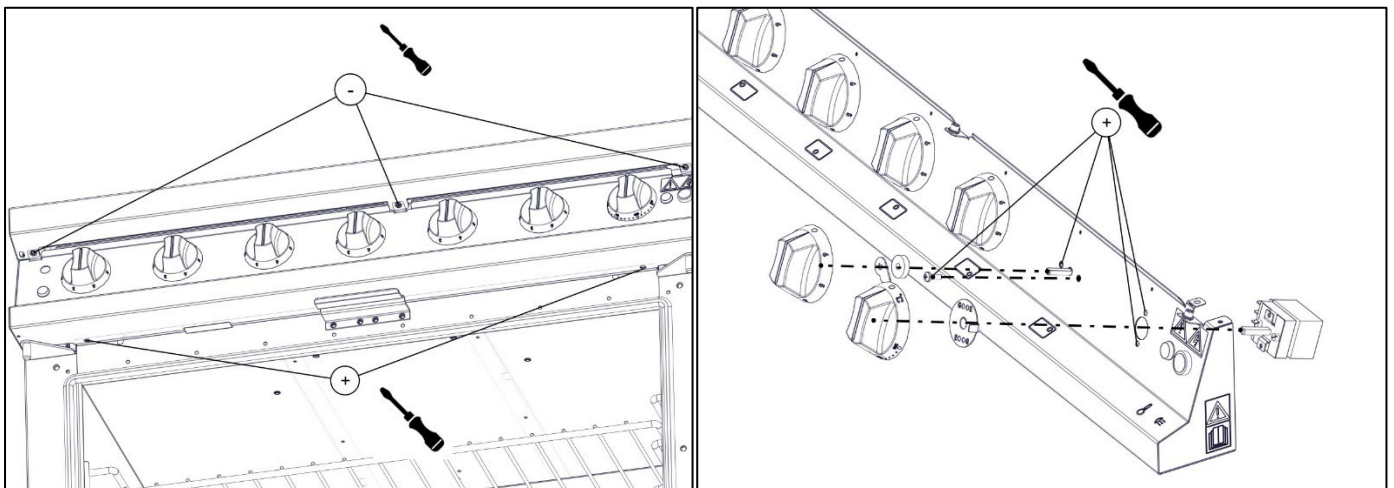

**E3164**

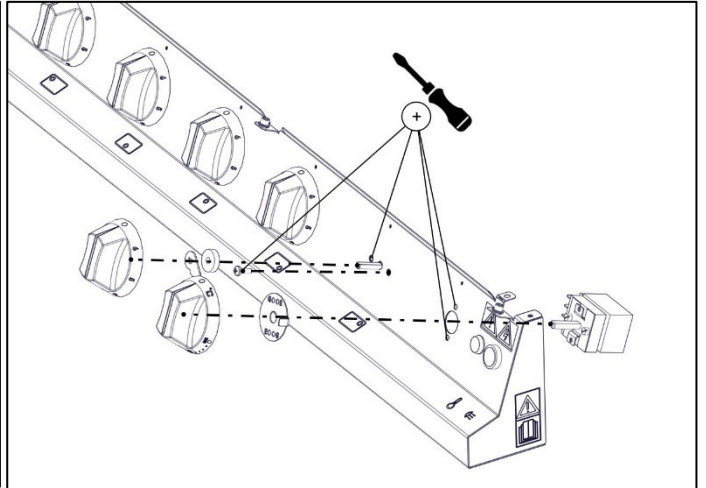
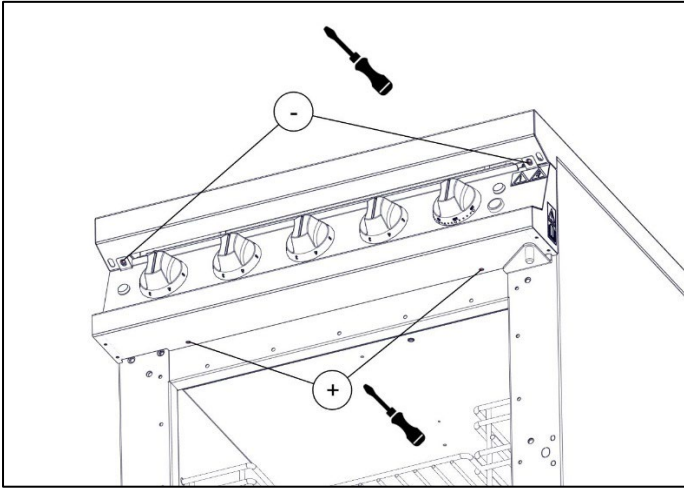

**9.9 SAFETY THERMOSTAT REMOVAL**

**E3196**

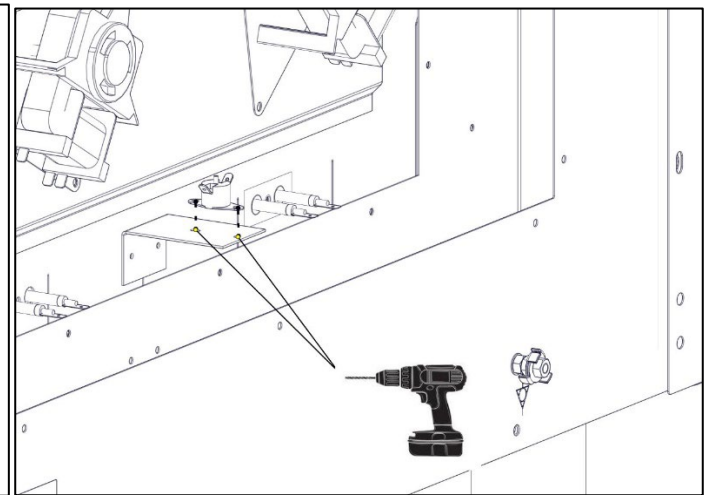
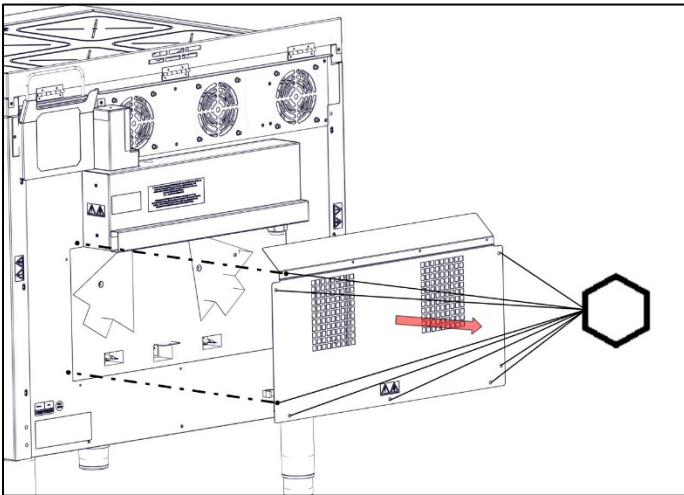

**E3164**

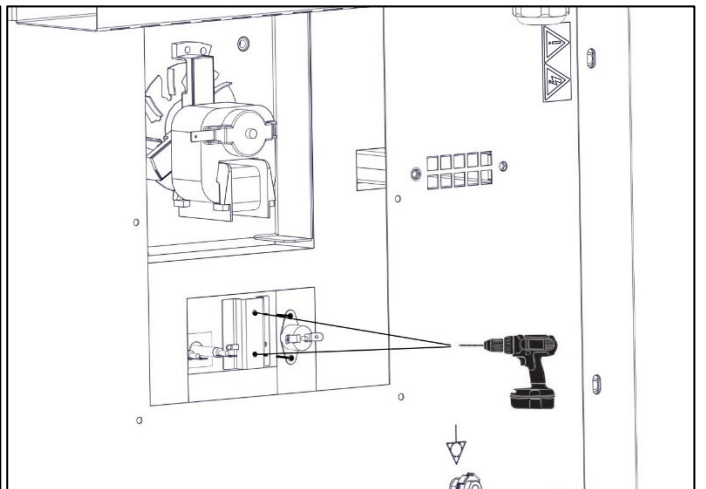
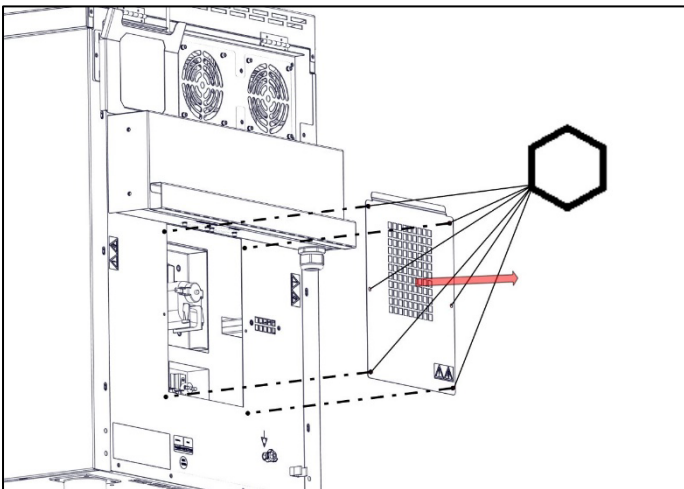

## 9.10 SAFETY THERMOSTAT RESET

**E3196**

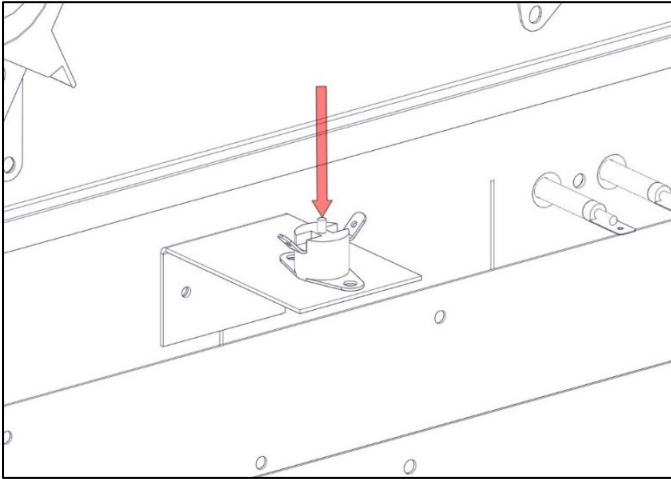

**E3164**

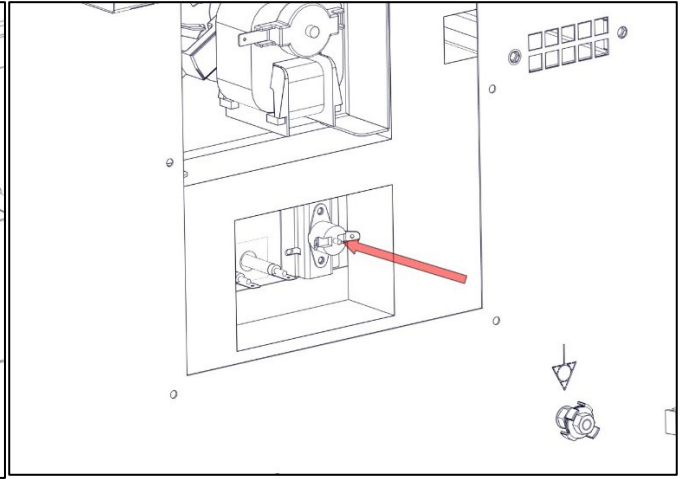

## 9.11 NEON REMOVAL

**E3196**

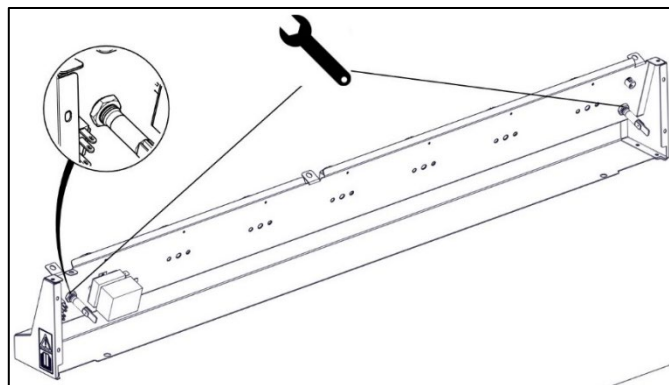
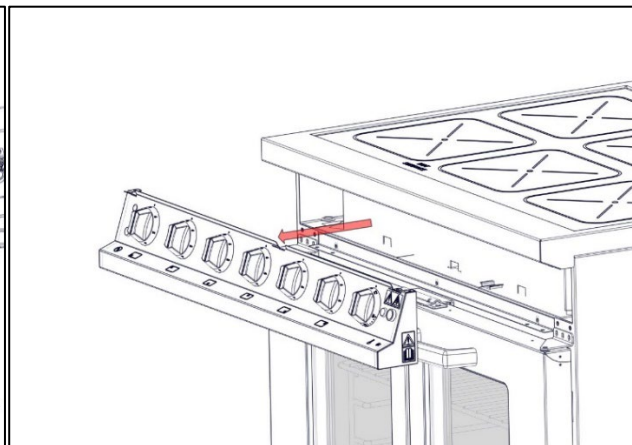
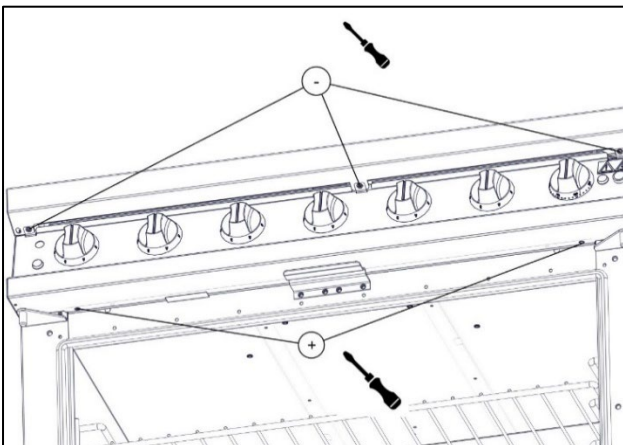

**E3164**

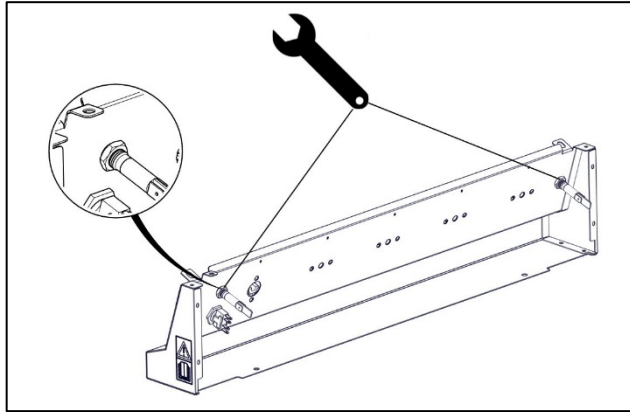
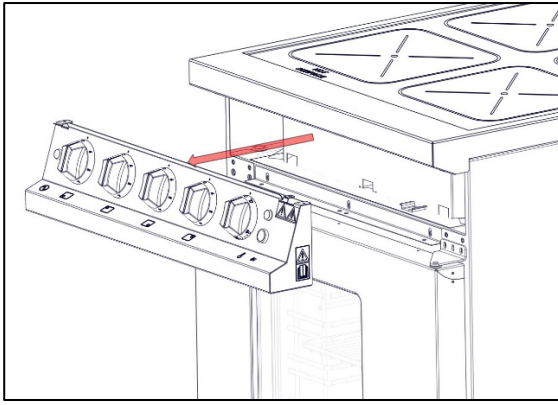
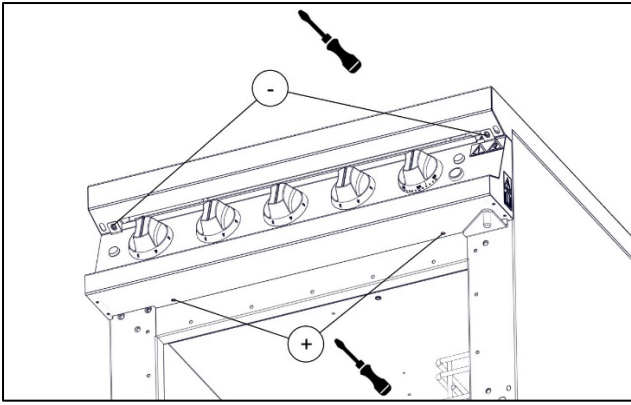

## 9.12 CIRCUIT DIAGRAMS

### E3196 Circuit Diagram

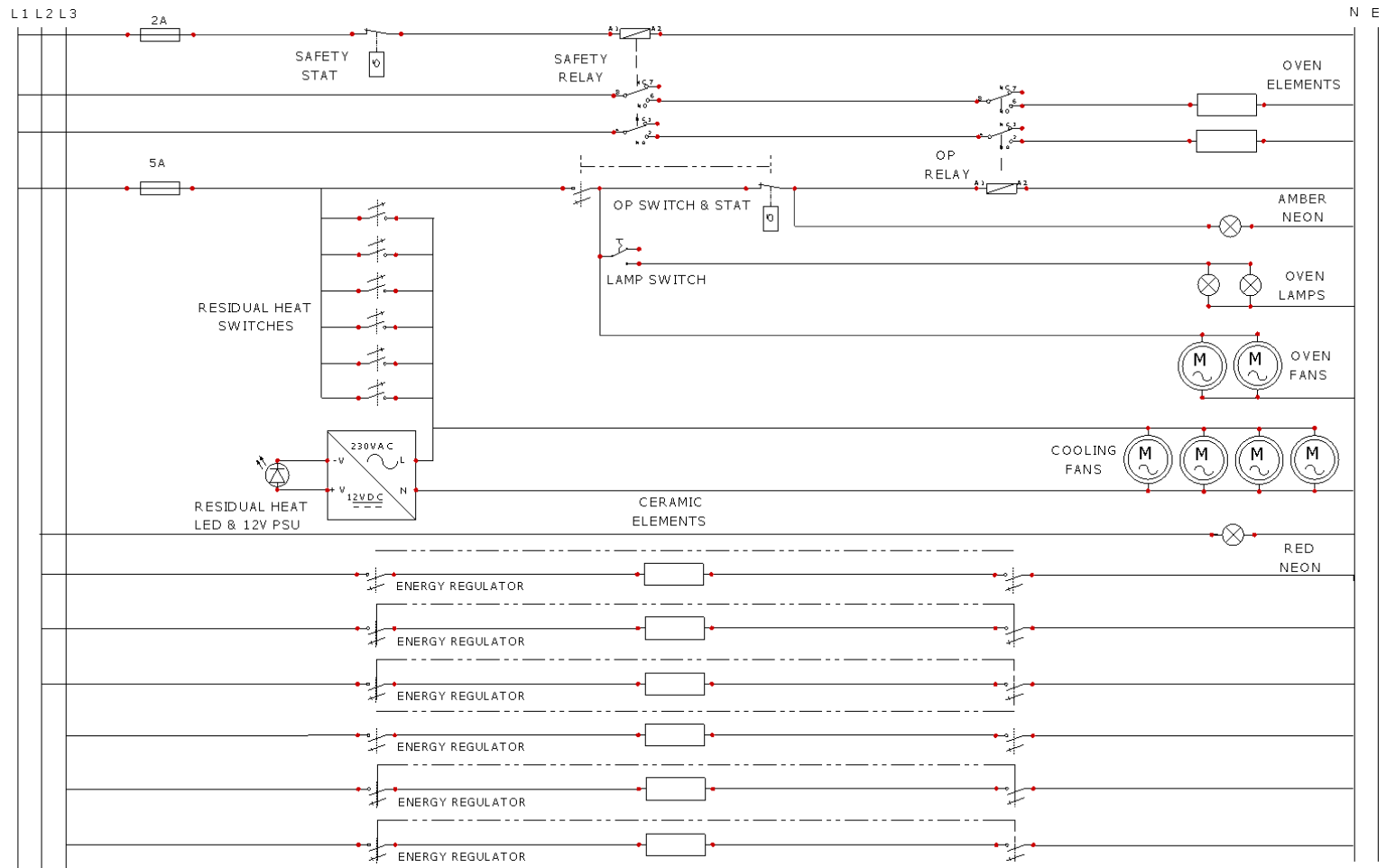

REFER TO  
 WIRING DIAGRAM MAIN AW59120  
 VIDAFLEX INFO AW59233  
 WIRE LIST AW59121

### E3164 CIRCUIT DIAGRAM

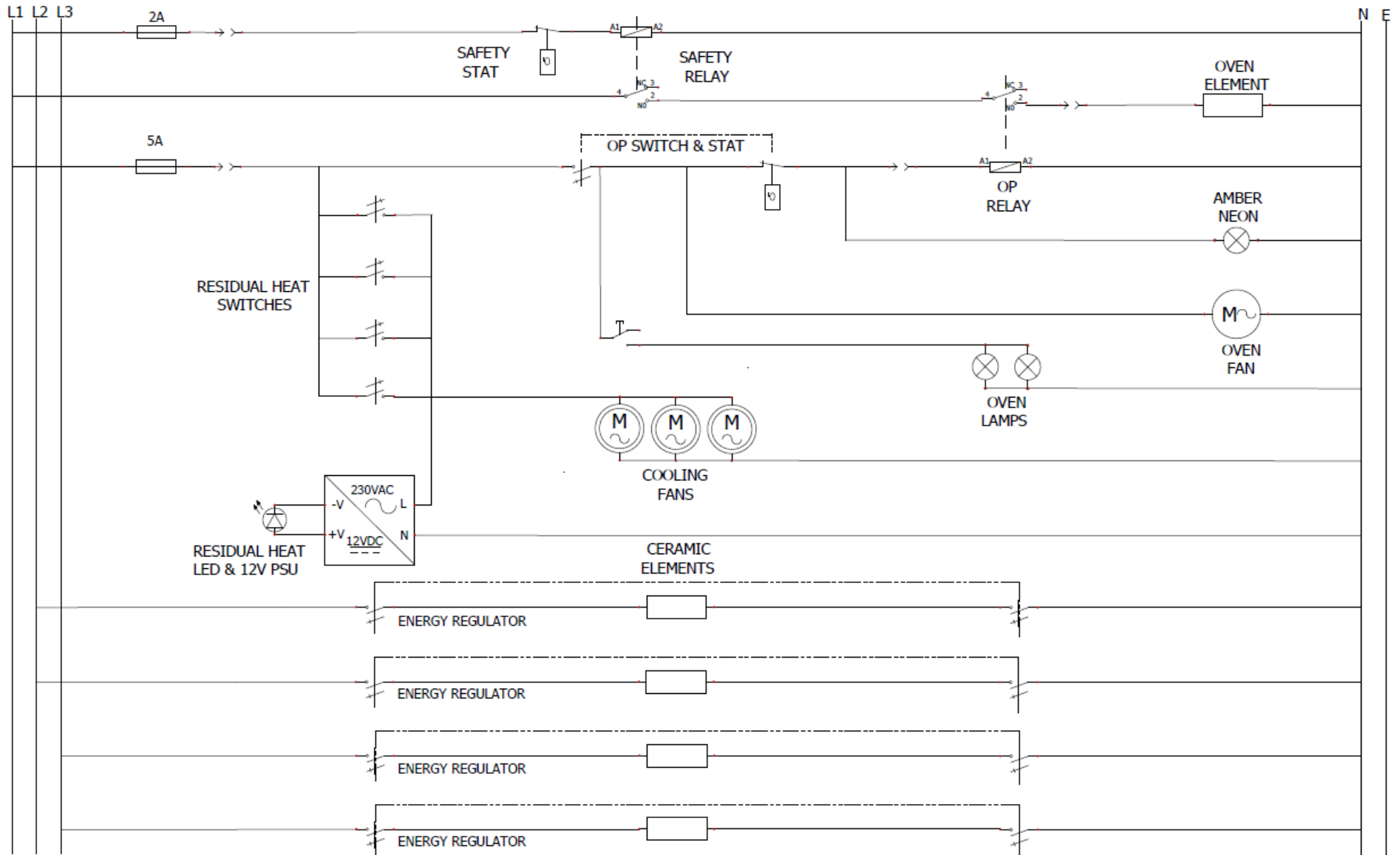

# 9.13 WIRING DIAGRAMS

## E3196 Wiring Diagram (Main)

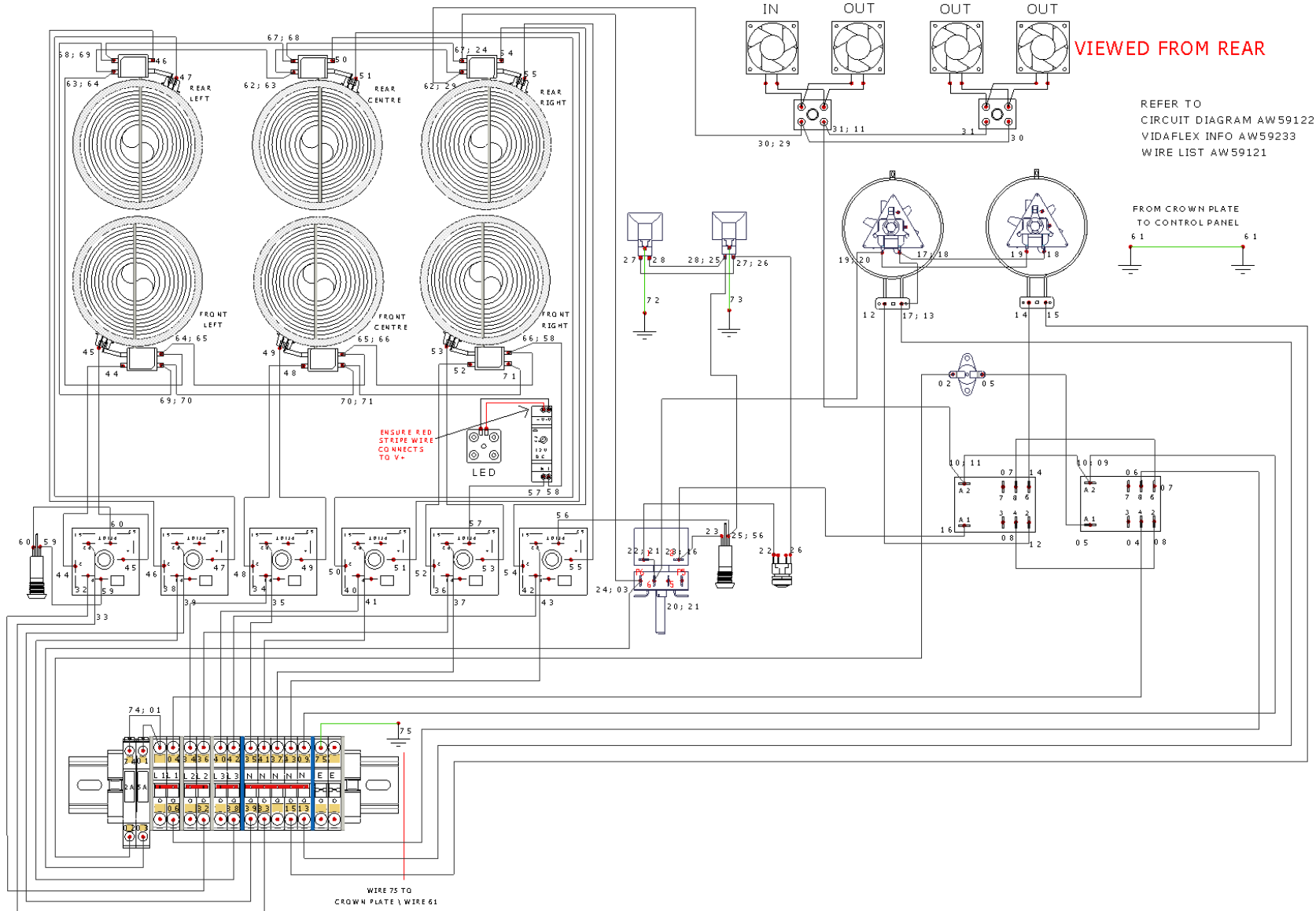

E3164 WIRING DIAGRAM (MAIN)

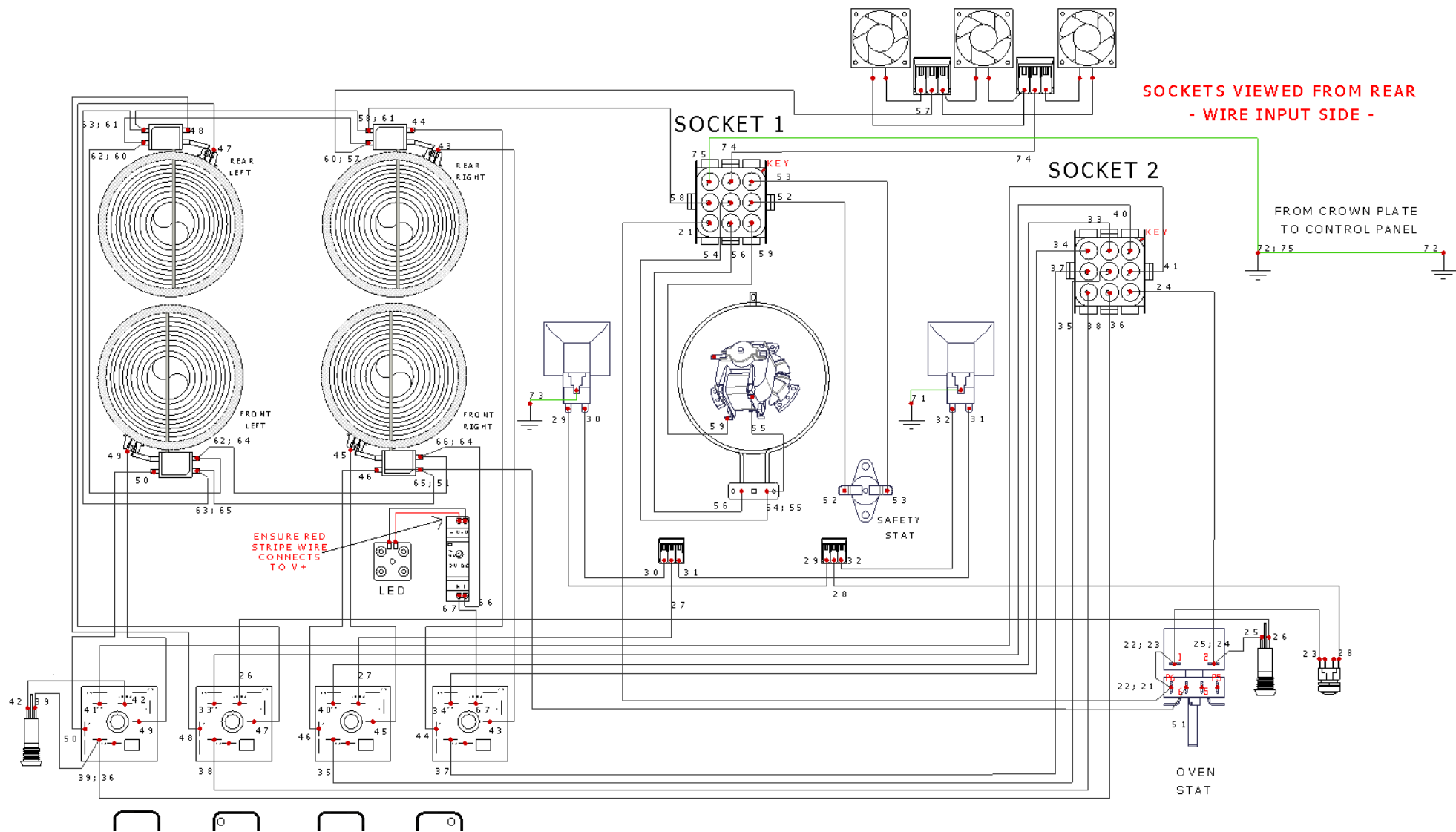

E3164 WIRING DIAGRAM (TERMINAL BOX)

PLUG 2

PLUG 1

PLUGS VIEWED FROM REAR  
- WIRE INPUT SIDE -

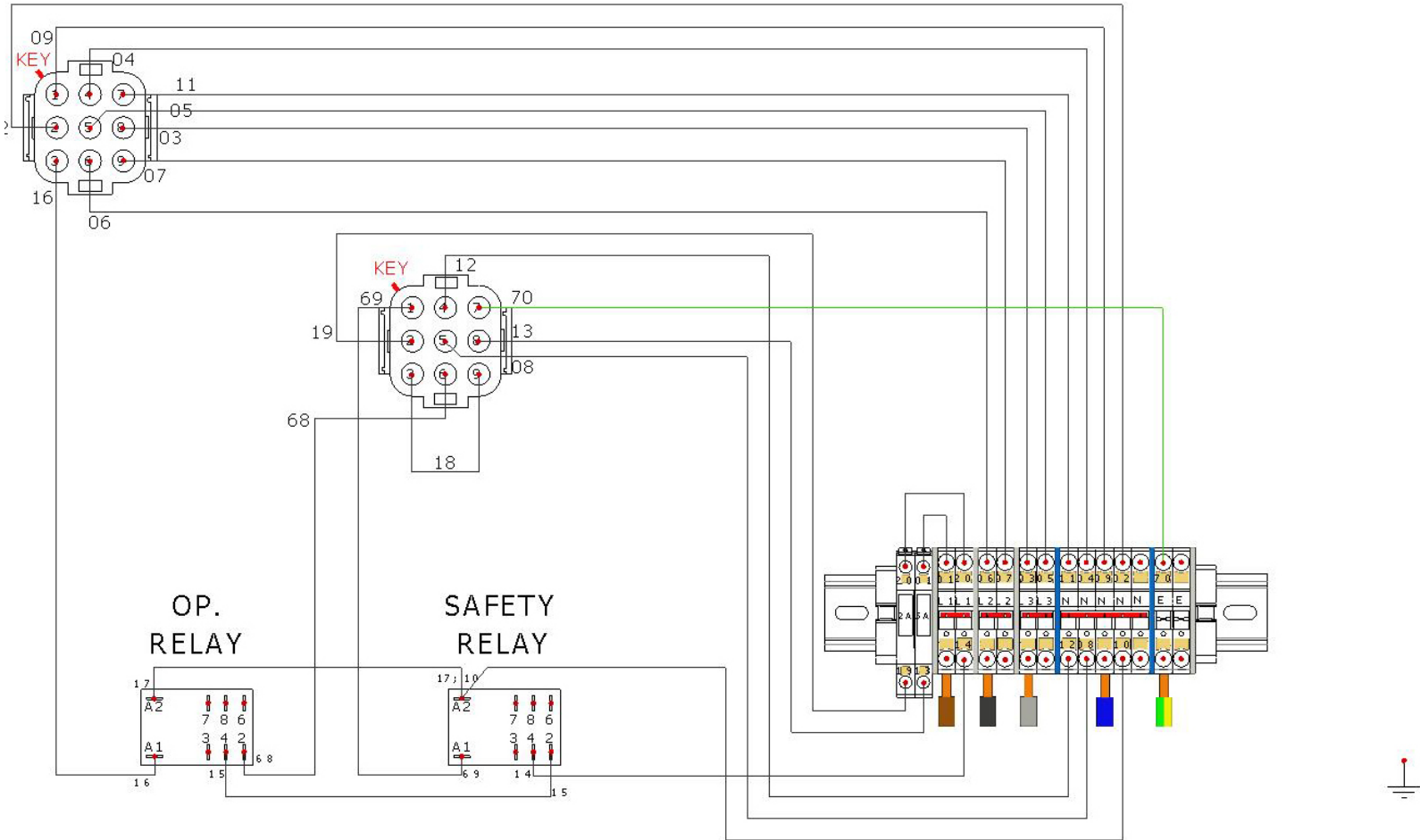

## 10.0 ACCESSORIES

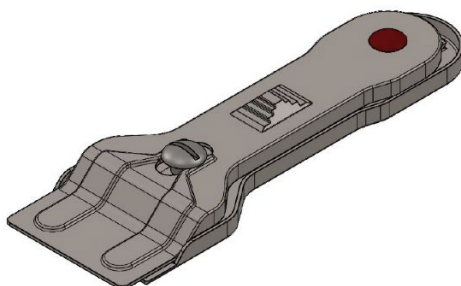

HOB SCRAPING TOOL

## 11.0 FAULT FINDING

FAULT	POSSIBLE CAUSES	REMEDY	USER	*ENG
No power	No mains voltage supply	Ensure isolator switch (if fitted) is switched on. Ensure mains plug, (if fitted), is connected.	✓	
		If OK above		✓
No power to oven	Safety thermostat tripped	Diagnose & fix fault then reset safety thermostat		✓
Oven not heating	Oven thermostat\switch faulty	Replace oven thermostat\switch		✓
	Heating element faulty	Replace element		
	Operating relay faulty	Replace relay		
	Safety relay faulty			
	Internal fuse blown	Diagnose & fix fault then replace fuse		
No fan rotation	Fan motor fault	Replace fan motor assy.		
No oven light	Light bulb\s faulty	Replace light bulb\s		✓
	Light switch faulty	Replace light switch		✓
Hob element not heating	Element faulty	Replace element		✓
	Control faulty	Replace control		
E3196 - 3 x front \ rear hob zones not working E3164 - both left \ right hob zones not working	1 phase of mains supply faulty	Investigate mains supply		✓
No "Hot Surface" LED indication 	LED module faulty	Replace LED module		✓
	12-volt DC supply faulty	Replace 12-volt DC supply		✓

\*ENG - Service engineer only.

## 12.0 SPARE PARTS

---

<b>Spare - Fitments</b>	
Air Filter	Glass Hob Assembly
Element Support	Warning Light Mount
Control Air Duct Cover	RH Outer Side Panel
Control Panel Assembly	RH Top Door Hinge
Door Hinge Bush	Oven Door Latch & Shim
Door Catch	RH Door Assembly
Oven Door Handle	LH Door Assembly
Castor Assembly - Swivel	Castor Assembly - Fixed
ST/ST Adjustable Leg	RH Bottom Door Hinge
LH Bottom Hinge	LH Outer Side Panel
LH Top Hinge	Terminal Box Cover
Hob Stay Rod	Element Mount
<b>Spare - Controls</b>	
2.3Kw Ceramic Electric Element	4 LED Block 12V DC 1.8W
Thermostat OTC Fan Oven	Oven Pilot Light (Amber)
Light Switch	Oven Control Knob
Element Control Knob	12V DC Power Supply
Mains Pilot Light (Red)	Blanking Plug
Energy Regulator	Safety/Operational Relay
Cable Gland Ø18.00-25.00mm	Mains Terminal (7Way)
Rear Cooling Fan	5a Fuse
9 Way Plug Set	Fuse Holder
<b>Spare – Oven Components</b>	
Oven Fan	Oven Safety Thermostat
Oven Element 3.2kW	Oven Light Bulb
Shelf Hanger	Door Seal Assembly
Oven Bottom Panel	Oven Shelf
Oven Lamp c/w Glass	

When ordering spare parts please quote **Model Number & Serial number**

This information will be found on data plate attached to the appliance

Visit our website for further spares information.

## 13.0 SERVICE INFORMATION

---

This unit carries an extensive mainland UK warranty. The warranty is in addition to and does not change your statutory or legal rights.

The warranty policy can be found on our website which details the conditions of the warranty and the exclusions.

<https://www.falconfoodservice.com/info-centre/policy>



Service calls to equipment under warranty will be carried out in accordance with the conditions of sale.

Warranty calls can be made between 8:30 am and 5:00 pm weekdays only.

To ensure your warranty enquiry is handled as efficiently as possible, ensure you have the following appliance information prior to calling us:

1. Model number – found on data plate
2. Serial number – found on data plate
3. Brief description of the issue

To contact Falcon for a warranty issue dial (UK only) 01786 455 200 and select Warranty Issues from the menu.