

E3830, E3860 & E3865 DOMINATOR PLUS Fryers



INSTALLATION and SERVICING INSTRUCTIONS

IMPORTANT

The installer must ensure that the installation of the appliance is in conformity with these instructions and National Regulations in force at the time of installation. Particular attention MUST be paid to:

Health & Safety at work, etc Act **I.E.E. Regulations for Electrical Installations**

Local and National Building Regulations **Electricity at Work Regulations**

Fire precaution Act

This appliance has been UKCA/CE marked based on compliance with the relevant Electrical and Electromagnetic Compatibility (EMC) and Regulations/Directives for the voltages stated on the data plate.

WARNING - TO PREVENT SHOCKS, ALL APPLIANCES, GAS OR ELECTRIC, MUST BE EARTHED.

On completion of the installation, these instructions should be left with the Engineer-in- Charge for reference during servicing. Further to this, The Users Instructions should be handed over to the User, having had a demonstration of the operation and cleaning of the appliance.

IT IS MOST IMPORTANT THAT THESE INSTRUCTIONS BE CONSULTED BEFORE INSTALLING AND COMMISSIONING THIS APPLIANCE. FAILURE TO COMPLY WITH THE SPECIFIED PROCEDURES MAY RESULT IN DAMAGE OR THE NEED FOR A SERVICE CALL.

PREVENTATIVE MAINTENANCE CONTRACT

To obtain maximum performance from this unit regular servicing of the appliance should be undertaken to ensure correct operation, it is functioning as intended, and safe to use. We recommend servicing in accordance with SFG20 Maintenance Schedules and as a minimum, after 2,500 hours of use, or annually, whichever comes first and that a maintenance contract be arranged with an appointed service contact. Visits may then be made at agreed intervals to carry out adjustments and repairs.



WEEE Directive Registration No. WEE/DC0059TT/PRO

At end of unit life, dispose of appliance and any replacement parts in a safe manner, via a licenced waste handler. Units are designed to be dismantled easily and recycling of all material is encouraged whenever practicable.

Falcon Foodservice Equipment

HEAD OFFICE AND WORKS

Wallace View, Hillfoots Road, Stirling.
FK9 5PY. Scotland.
Phone: 01786 455200

T100774 Ref. 22

CONTENTS

1.0	SAFETY GUIDANCE	3
1.1	GENERAL SAFETY	3
1.2	INSTALLATION SAFETY	4
1.3	ELECTRICAL SAFETY	4
1.4	FIRE SAFETY	4
1.5	MAINTENANCE SAFETY	5
2.0	TRANSPORT & INSTALLATION	7
2.1	TRANSPORT & POSITIONING	7
2.2	MODEL NUMBERS, NETT WEIGHTS and DIMENSIONS	8
2.3	SITING	8
2.4	ELECTRICAL CONNECTION	8
2.5	ELECTRICAL RATINGS	9
3.0	ASSEMBLY and COMMISSIONING	9
3.1	ASSEMBLY	9
3.2	CASTORS	9
3.3	CONNECTION TO THE ELECTRICAL SUPPLY	10
3.4	COMMISSIONING	10
3.5	High Temperature Limit Device	10
3.6	INSTRUCTION TO USER	10
4.0	SERVICING and MAINTENANCE	11
4.1	SERVICE INFORMATION	11
4.2	ELECTRICAL CONTROL GEAR	12
4.3	NEON INDICATOR LAMPS	12
4.4	THERMOSTATS	12
4.5	CONTACTOR	12
4.6	ELEMENTS	13
4.7	CLEANLINESS	13
4.8	TILT SWITCH	13
5.0	SPARES	13
6.0	WIRING DIAGRAMS	Error! Bookmark not defined.
6.1	E3830 wiring diagram	Error! Bookmark not defined.
6.2	E3830 circuit diagram	Error! Bookmark not defined.
6.3	E3860 wiring diagram	Error! Bookmark not defined.
6.4	E3860 circuit diagram	Error! Bookmark not defined.
6.5	E3865 wiring diagram	Error! Bookmark not defined.
6.6	E3865 circuit diagram	Error! Bookmark not defined.

1.0 SAFETY GUIDANCE

1.1 GENERAL SAFETY



- 1.1.1 These instructions are only valid if the country code appears on the appliance. If the code does not appear on the appliance, refer to the technical instructions for adapting the appliance to the conditions for use in that country.
- 1.1.2 These appliances have been UKCA/CE-marked based on compliance with the Electrical and Electromagnetic Compatibility (EMC) Regulations/Directives for the Voltages as stated on the data plate.



- 1.1.3 This equipment is for professional use only and must be used by qualified persons.
- 1.1.4 Never leave this appliance unsupervised when in use and always turn products off at the end of service.



- 1.1.5 The installer must instruct the responsible person(s) of the correct operation and maintenance of the appliance.
- 1.1.6 Check that no damage has occurred to the appliance or supply cord during transit. If damage has occurred, do not use this appliance.



- 1.1.7 If fitted to the appliance, ensure the supply cord is routed free from the appliance to avoid damage.
- 1.1.8 MIN-Level Mark: Medium should never be allowed to drop below the mark. Should this occur, top up immediately or switch off the fryer.



- 1.1.9 Suitable Protective clothing must be worn when topping up whilst the fryer is hot.
- 1.1.10 To prevent surge boiling. DO NOT EXCEED recommended loads or charge pan with over-wet food items. NEVER leave a working appliance unattended.
- 1.1.11 If the appliance is fitted with an oil bucket, take care when removing as oil bucket is heavy when full.
- 1.1.12 Training and Competence: To help ensure the safe use of this appliance there is a requirement for you to provide whatever information, instruction, training, and supervision as is necessary to ensure, so far as is reasonably practicable, the health and safety of all users.
- 1.1.13 For further help and information on training and competence we refer you to the Health & Safety Executive website; www.hse.gov.uk document ref: health and safety training INDG345. International customers should default to the health and safety guidelines provided by your government body.
- 1.1.14 Risk Assessment: As part of managing the health and safety of your business you must control any risks identified in your commercial kitchen. To do this you need to think about what might cause harm to people and decide whether you are taking reasonable steps to prevent that harm. This is known as risk assessment. It is important to consider the environment around the product as well as the product itself. For example, oil or food spills will present a significant risk so users so the need to immediately clean up such spills must be reflected in staff training.
- 1.1.15 Record the training that you provide and support it by providing safe system of work (SSOW) documents that set out procedures to be followed for potentially hazardous tasks.



- 1.1.16 For further help and information on risk assessments we would refer you to you the Health and Safety Executive website; www.hse.gov.uk document ref: risk assessment INDG163. International customers should default to the health and safety guidelines provided by your government body.

1.2 INSTALLATION SAFETY



- 1.2.1 Installation must meet national or local regulations. Attention must be paid to: safety (installation & use) regulations, health and safety at work act, local and national building regulations, fire precautions act.
- 1.2.2 The installer must instruct the responsible person(s) of the correct operation and maintenance of the appliance.
- 1.2.3 On gas appliances, only competent persons are allowed to service or convert the appliance to another gas type.
- 1.2.4 Put a documented system in place for periodic inspections, testing and maintenance of our gas/ electrical appliances. Check that the fixed electrical installation has been inspected and tested by a competent electrical contractor (e.g. NICEIC-approved or ECA member) as prescribed in BS7671, within the last 5 years.

1.3 ELECTRICAL SAFETY



- 1.3.1 To prevent shocks, this appliance must be earthed.
- 1.3.2 This unit is fitted with an equipotential connection at the rear on the base.
- 1.3.3 Before attempting any maintenance, isolate the appliance at the mains switch and take steps to ensure that it is not inadvertently switched on.
- 1.3.4 We recommend, Supplementary electrical protection with the use of a type A residual current device (RCD).
- 1.3.5 Fixed wiring appliances incorporate a locally situated switch disconnecter.
- 1.3.6 to connect to, which is easily accessible for switching off and safe isolation purposes. The switch disconnecter must meet the specification requirements of IEC 60947.

1.4 FIRE SAFETY



Fryers can present various hazards in the catering environment if not correctly used, operated, and maintained. Hazards including fire, burns from hot oil, contact with hot surfaces, fumes from boiling cleaning chemicals, eye injuries from splashes and slips from oil spillages.

Operator Competency and Training

Ensure you are trained in the safe and proper use of the fryer and know how to turn it off and switch the power or gas off at the mains.

- 1.4.1 Ensure you are familiar with the kitchen fire safety procedures and the location and proper use of correct fire safety equipment.

Fryer Safety Equipment

- 1.4.2 Provide an appropriate BS compliant fire blanket, and an adequate number of fire extinguishers that comply with BS EN 3 (parts 1-6) and carry a BAFE or LPCB approval mark. At least one must be appropriate for use on electrical fires, and one for deep-fat fryers (Class F).

Fryer Suppression System

- 1.4.3 We recommend kitchen equipment and extraction systems are protected with a fire suppression system. Check your insurance as this may also be a condition of your policy.
- 1.4.4 Protect cooking and extraction equipment (including any associated extraction ductwork and hoods inside the building) by having an extinguishing system installed, in line with (or the equivalent of) [LPS 1223](#). The system should include a local alarm, automatic activation by a detection system and manual activation – located a safe distance away from the cooking equipment, preferably by a fire escape route door.

Operational Fryer Safety

- 1.4.5 Do not leave the fryer unattended when powered on or when it is in use.
- 1.4.6 Always switch the fryer off and replace the pan cover/ lid when not in use.

Cleaning

- 1.4.7 Ensure fryers are regularly cleaned serviced and maintained by a qualified and competent service provider, and there is enough room around the appliance to do so.
- 1.4.8 Ensure that the appliance, surrounding work area and extraction system are regularly cleaned, (at least weekly) to avoid the build-up of fats oils and greases that could present a fire risk. A deep clean should be undertaken at least every 6 months by a specialist contractor.

Oil Safety

- 1.4.9 Do not operate the fryer with no or low oil levels.
- 1.4.10 Solid Fat (e.g. Beef Tallow) must be melted using the fat melt mode in order to avoid fire caused by burning of the fat and/or overheating. We do not recommend using Solid Fat if the fryer control does not have a Fat Melt Cycle.
- 1.4.11 Regularly change your cooking oil. Use colour charts to check on oil quality.
- 1.4.12 If you see the cooking oil or fat smoking, switch the fryer off, allow to cool, drain oil, clean and dry fryer pan thoroughly and replace with fresh oil. If the clean fryer oil smokes when heated, switch off immediately and contact service engineer. Do not switch fryer back on.
- 1.4.13 Never add water to the fryer medium at any time.



Gas and Electrical Isolation Points

- 1.4.14 Ensure any separate gas shut off switches and electric switches provided for cooking equipment and/or extractor fans are accessible and clearly labelled.

Care and Maintenance of Thermal and Operational Safety Devices

- 1.4.15 Your fryer is fitted with a thermal safety device. This will stop heating of medium if it becomes overheated. This appliance will always fail safe so long as there is no damage to the thermal safety device.
- 1.4.16 Failure to clean and check the safety and operational thermostats can impact the performance of the appliance and increase the risk of an appliance fire.
- 1.4.17 Damage to the thermostat sensors or their capillaries can increase the risk of overheating or fire.
- 1.4.18 Do not operate the fryer if the safety devices located within the fryer pan appear to be dislodged or damaged.



1.5 MAINTENANCE SAFETY



- 1.5.1 Unless otherwise stated, parts which have been protected by the manufacturer must not be adjusted by the installer or end user.
- 1.5.2 We recommend that the oil level sensor (UK Patent Serial No. GB2584184) in X or FX models should be serviced annually.
- 1.5.3 Before any cleaning is undertaken, isolate appliance from mains power supply at isolator switch.
- 1.5.4 Suitable protective clothing must be worn when cleaning this appliance.
- 1.5.5 If filtration is fitted, never pump water through the filtration pump at any time! Water and hot oil are an explosive mixture.
- 1.5.6 Oil must be allowed to cool to a safe temperature before draining. Do not overfill the oil bucket. All spills onto the product and on the floor should be cleaned up immediately
- 1.5.7 The appliance must not be cleaned with a jet of water or steam cleaned. Do not use acid or halogen-based (e.g., chlorine) descaling liquids, flammable liquids, cleaning aids or cleaning powders.
- 1.5.8 Failure due to lack of proper cleaning is not covered by warranty.
- 1.5.9 Particular attention must be paid to cleaning the Thermostat bulb & Capillaries.





1.5.10 Take care when cleaning not to dislodge or damage thermostat sensors mounted on the base and side of the pan.



1.5.11 If the thermostats or capillaries are damaged, then do not turn the appliance on and contact Falcon or you approved service provider to undertake the necessary repairs.

1.5.12 To obtain maximum performance from this unit regular servicing of the appliance should be undertaken to ensure correct operation, it is functioning as intended, and safe to use. We recommend servicing in accordance with SFG20 Maintenance Schedules and as a minimum, after 2,500 hours of use, or annually, whichever comes first and that a maintenance contract be arranged with an appointed service contact. Visits may then be made at agreed intervals to carry out adjustments and repairs.



1.5.13 During Servicing of the appliance, where applicable, please ensure seals are checked. If the integrity of the seal is compromised, it must be replaced

2.0 TRANSPORT & INSTALLATION

ELECTRICAL SAFETY AND ADVICE REGARDING SUPPLEMENTARY ELECTRICAL PROTECTION

Commercial kitchens and foodservice areas are environments where electrical appliances may be located close to liquids or operate in and around damp conditions or where restricted movement for installation and service is evident.

The installation and periodic inspection of the appliance should only be undertaken by a qualified, skilled and competent electrician; and connected to the correct power supply suitable for the load as stipulated by the appliance data label.

The electrical installation and connections should meet the necessary requirements to the local electrical wiring regulations and any electrical safety guidelines.

We recommend:

- Supplementary electrical protection with the use of a type A residual current device (RCD)
- Fixed wiring appliances incorporate a locally situated switch disconnector to connect to, which is easily accessible for switching off and safe isolation purposes. The switch disconnector must meet the specification requirements of IEC 60947.

Your attention is drawn to:

BS 7671:2018–Guidance Note 8 - 8.13: Other locations of increased risk.

It is recognized that there may be locations of increased risk of electric shock other than those specifically addressed in Part 7 of BS 7671. Examples of such locations could include laundries where there are washing and drying machines in close proximity and water is present, and commercial kitchens with stainless steel units, where once again, water is present.

Where because of the perception of additional risks being likely, the installation designer decides that an installation or location warrants further protective measures, the options available include:

- Automatic Disconnection of Supply (ADS) by means of a residual current device having a residual operating current not exceeding 30mA;
- Supplementary protective equipotential bonding; and
- Reduction of maximum fault clearance time.

The provision of RCDs and supplementary bonding must be specified by the host organization's appointed installation designer or electrical contractor and installed by a suitably qualified and competent electrician so as to comply with Regulations 419.2 and 544.2.

2.1 TRANSPORT & POSITIONING

General warnings for transport:

- a) Observe the maximum load and stacking limits.
- b) Follow the indications shown on the packaging, any instructions on the equipment, including those on the points where forklift trucks cannot be used.
- c) Danger of crushing during transportation due to the weight of the appliance.
- d) Hands and fingers may be crushed.
- e) Wear suitable protective clothing when transporting.
- f) Danger of overturning during transporting
- g) Danger of crushing due to the appliance overturning on persons.
- h) Take care over the centre of gravity of the appliance.
- i) Take great care to ensure that the appliance does not overturn during transportation, lifting and after installation.

Take care over the width and height of accesses during transportation.

Take care not to damage the appliance due to narrow doorways: doorways less than 80cm wide, remove any handles etc.

Check that all the parts of the appliance are intact and have not been damaged during transportation. If damaged due to transportation, inform the specialised reseller/ haulier immediately.

To position the appliance, it is recommended to use the mount offered by the manufacturer, should you want to do things differently, it is necessary to take account of the weight of the appliance.

Before permanently fixing the appliance in position, the Water, Electrical and Gas Connections must be made. (See relative sections).

Once the appliance is installed, the electrical power cable must be protected, and never stretched or tugged.

Remove all packaging materials and peel away the protective plastic film from all external surfaces of the appliance.



UNLESS OTHERWISE STATED, PARTS WHICH HAVE BEEN PROTECTED BY THE MANUFACTURER ARE NOT TO BE ADJUSTED BY THE INSTALLER.

Please ensure that any plastic coatings are removed prior to use. Before operation, the pan requires to be thoroughly cleaned and dried.

Discolouration of heated parts is caused by factory testing to ensure a satisfactory unit. It does not affect quality or performance.

2.2 MODEL NUMBERS, NETT WEIGHTS and DIMENSIONS

Model	Width (mm)	Depth (mm)	Height (mm)	Weight (kg)
E3830 Fryer	300	770	890	45
E3860 Fryer	600	770	890	73
E3865 Fryer	600	770	890	85

2.3 SITING

Before connecting appliance to electricity supply, it must be correctly positioned and levelled. Levelling is affected by height adjustable legs or castors.

2.4 ELECTRICAL CONNECTION

The unit is designed for use on AC supplies only and terminals are arranged for either 2 phase operation (*E3830 model*) or 3 phase (*E3860 & E3865 models*).

Cable entry is located at appliance rear in the form of a cable gland.

A suitably rated isolating switch with contact separation of at least 3mm in all poles must be installed. All wiring must be executed in accordance with regulations listed on title page of this document.



This appliance must be earthed.

Check that no damage has occurred to the appliance and power cable during transit. If damage has occurred do not use the appliance.

Ensure that the mains power cable is routed free from the appliance to avoid damage.

We recommend supplementary electrical protection with the use of a type A residual current device (RCD). Periodical testing, repair and fixing wiring connection should only be undertaken by a skilled and competent electrician.

2.5 ELECTRICAL RATINGS

The electrical rating is stated on appliance data plate.

Model	L1	L2	L3
E3830 Fryer	21.7A	21.7A	
E3860 Fryer	31.7A	15.85A	31.7A
E3865 Fryer	21.7A	43.5A	21.7A

3.0 ASSEMBLY and COMMISSIONING

3.1 ASSEMBLY

The appliance is supplied complete and ready to be connected to the mains supply.

Position unit in desired location and level it.

For units supplied with feet, turn lower section of each leg clockwise to raise corresponding corner height or anti-clockwise to lower it.

3.2 CASTORS

For units supplied with castors, undo grub screw (1) and use a spanner to adjust the castor height. (2) Turn clockwise to raise level and anti-clockwise to lower. Secure grub screw when task is completed

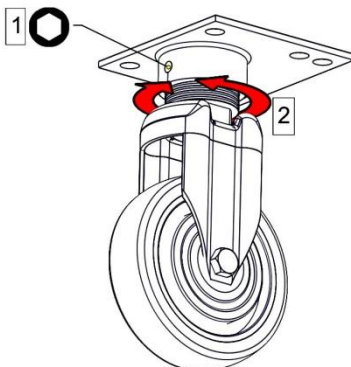

3.3 CONNECTION TO THE ELECTRICAL SUPPLY

To gain access to terminals, proceed as follows: -

Remove fixings at unit rear to remove cover and access electrical connections.

Undo cable gland.

Feed cable through cable gland into electrical box. Connect leads to respective terminals.

Tighten cable gland. Replace cover.

3.4 COMMISSIONING

Fill pan(s) with oil to "MIN" mark on element guard (i.e. approximately 20 litres for E3830 model, 40 litres for E3860 and 20 litres per pan for E3865 models) and switch on a isolator switch. Open door and press on/off switch to 'ON' position. Turn thermostat to maximum setting and check that it operates at the correct temperature of 190°C.

The importance of never switching on the elements unless they are covered by oil or water must be stressed.



WARNING

DO NOT USE SOLID FAT.

3.5 High Temperature Limit Device

The fryers are fitted with a high temperature limit device. This ensures that oil cannot become overheated to reach a dangerous temperature level.

In the case of operating thermostat failure, allowing oil temperature to rise above predetermined legislation safe zone (230°C), limit device will activate and cut power to controller and elements. To re-set temperature limit thermostat:

1. Switch the fryer ON/OFF switch to OFF position.
2. Allow oil to cool below 150°C.
3. To reset the limit thermostat, unscrew black dust cap located at element box rear. Press the reset button and replace the cap.
4. Turn fryer ON/OFF switch to ON position.
5. Reselect temperature.
6. If the limit thermostat reactivates, carry out fault finding on the temperature control circuitry.

3.6 INSTRUCTION TO USER

After installing and commissioning appliance, hand user instructions to user or purchaser.

Ensure that person(s) responsible is (are) made familiar with use and maintenance of unit.

4.0 SERVICING and MAINTENANCE

4.1 SERVICE INFORMATION

This unit carries an extensive mainland UK warranty. The warranty is in addition to and does not change your statutory or legal rights.

The warranty policy can be found on our website which details the conditions of the warranty and the exclusions.

<https://www.falconfoodservice.com/info-centre/policy>



Service calls to equipment under warranty will be carried out in accordance with the conditions of sale.

Warranty calls can be made between 8:30 am and 5:00 pm weekdays only.

To ensure your warranty enquiry is handled as efficiently as possible, ensure you have the following appliance information prior to calling us:

1. Model number – found on data plate
2. Serial number – found on data plate
3. Brief description of the issue

To contact Falcon for a warranty issue dial (UK only) 01786 455 200 and select Warranty Issues from the menu.



BEFORE ATTEMPTING ANY MAINTENANCE TASK, ISOLATE THE APPLIANCE AT THE MAIN SUPPLY. TAKE STEPS TO ENSURE THAT IT MAY NOT BE INADVERTENTLY SWITCHED ON.



BEFORE ATTEMPTING ANY MAINTENANCE, ENSURE THE PAN IS EMPTY.



MAINTENANCE CHECK

Regular servicing of the appliance should be undertaken to ensure correct operation, it is functioning as intended, and safe to use. We recommend servicing after 2,500 hours of use, or annually, whichever comes first.

Any maintenance schedule should be carried out in accordance with SFG20 Maintenance Schedule. Should any issues with the integrity of the components be identified these should be replaced. If the appliance is not considered safe the unit should be removed from service and the responsible person advised why the unit is not safe to use and what remedial action is needed. Contents of the maintenance schedule should be agreed with the maintenance provider.

4.2 ELECTRICAL CONTROL GEAR

The mains terminals are located at rear of unit.

The contactor(s) are contained within a box at the front. To gain access, open door and remove cover panel behind.

The control thermostat(s) and neon lamps are mounted on the fascia panel, which is secured by four fixings.

4.3 NEON INDICATOR LAMPS

These must be replaced by new lamps in event of failure.

Mains Indicator – RED neon. Operating thermostat indicator (elements ON) – AMBER neon.

To replace a faulty lamp, first remove fascia panel and pull off push-on terminals. Remove lamp by undoing fixing nut at rear.

4.4 THERMOSTATS

A defective safety or operating thermostat cannot be repaired and must be replaced.

These are electromechanical controls with an oil filled sensor bulb and capillary. When heated above a pre-determined temperature the sensor system oil expansion is sufficient to activate a built-in switch.

Control thermostat

The adjustable control thermostat is mounted upon control panel.

The capillary tube passes through the pan wall and is sealed with a small gland which must not be over tightened or kinked. The phial must be fixed in position within pan before tightening gland. The phial tip should protrude from protective tube by 33mm. The thermostat capillary tube between the gland and body of the thermostat behind the control panel must be covered with sleeve insulation.

Safety Thermostats

The safety thermostat is located within the element box. It has a fixed setting and manual re-set button at rear of element box. In the event of control thermostat failure and resultant overheating of frying medium, safety thermostat will trip supply to elements before oil temperature becomes dangerous.

To restore circuit having rectified the fault, it is necessary to press the re-set button. This is situated at the rear of the element box. The oil must be allowed to cool to enable safety thermostat to be re-set.

The capillary tube passes through the underside of the element box and is sealed with a small gland which must not be over tightened. The capillary to run along the side of the element leg down towards the element clip as shown below. Avoid direct contact with element. The safety stat phial should be located centrally within element clip before tightening the gland. The thermostat capillary tube remaining within the element head between the gland and body of the the thermostats must be covered with sleeve insulation.

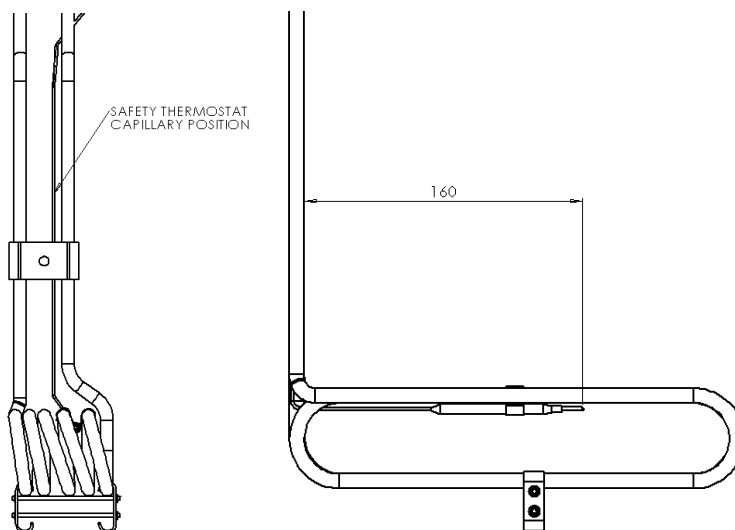

4.5 CONTACTOR

Located in the electrical box. This should require little or no maintenance under normal circumstances.

After long service, the contacts may become pitted and at that point, new contacts should be fitted.

4.6 ELEMENTS

These are individually replaceable. Access to terminals and fixing nuts is gained upon removing element box cover. When fitting a new element, ensure that sealing gasket is fitted and tighten fixing nut firmly, preferably with the aid of a tubular box spanner or socket.

When re-fitting element box cover, check condition of oil resistant gasket. Do not use excessive force when securing cover as this may deform it and allow oil to enter box.

4.7 CLEANLINESS

To maintain maximum performance, the pan must be kept clean. Periodically, oil must be drained off and the pan should be filled with water and detergent. Boil up contents and drain whilst still hot before flushing out with clean water. **Thoroughly dry pan and all fittings before re-filling with oil.** The elements can be lifted and hinged backward to gain full access to all surfaces of pan and elements.

4.8 TILT SWITCH

Located in element terminal box, this component should require no maintenance.

5.0 SPARES

When ordering spares, quote the unit type and serial number. This information will be found on data plate located on cover panel behind door.

An identity label is also provided on appliance front frame.