



DOMINATOR*PLUS*

User, installation and servicing instructions

ELECTRIC CHARGRILL

E3625/E3925

Read these instructions before use

DATE PURCHASED:

MODEL NUMBER:

SERIAL NUMBER:

DEALER:

SERVICE PROVIDER:

T100982

Rev No 12

Published: 23/03/2026

Dear Customer

Thank you for choosing Falcon Foodservice Equipment.

This manual can be downloaded from www.falconfoodservice.com or scan here:



IMPORTANT: Please keep this manual for future reference.

Falcon Foodservice Equipment

Wallace View, Hillfoots Road,
Stirling, FK9 5PY, Scotland.
Tel : 01786 455200

PREVENTATIVE MAINTENANCE CONTRACT

To obtain maximum performance from this unit regular servicing of the appliance should be undertaken to ensure correct operation, it is functioning as intended, and safe to use. We recommend servicing in accordance with SFG20 Maintenance Schedules and as a minimum, after 2,500 hours of use, or annually, whichever comes first and that a maintenance contract be arranged with an appointed service contact. Visits may then be made at agreed intervals to carry out adjustments and repairs.



WEEE Directive Registration No. WEEE/DC0059TT/PRO

At end of appliance life, dispose of appliance and any replacement parts in a safe manner, via a licensed waste handler. Appliances are designed to be dismantled easily and recycling of all material is encouraged whenever practicable.

CONTENTS

1.0	SYMBOLS	5
2.0	SAFETY GUIDANCE	6
2.1	GENERAL SAFETY	6
2.2	INSTALLATION SAFETY	7
2.3	ELECTRICAL SAFETY	7
2.4	FIRE SAFETY	8
2.5	MAINTENANCE SAFETY.....	9
3.0	APPLIANCE INFORMATION	11
4.0	OPERATION	12
4.1	COMPONENT PARTS	12
4.2	CONTROLS	14
4.3	USING THE APPLIANCE.....	15
4.4	CHEF'S RECOMMENDATIONS.....	16
5.0	CLEANING AND MAINTENANCE	17
5.1	CLEANING AND MAINTENANCE.....	18
5.2	PTFE LINER REMOVAL FOR CLEANING.....	21
5.3	PTFE SHEET REMOVAL.....	22
6.0	SPECIFICATION	23
6.1	APPLIANCE WEIGHT TABLE.....	23
6.2	TECHNICAL DATA TABLE	23
7.0	DIMENSIONS / CONNECTION LOCATIONS	24
8.0	TRANSPORTATION & INSTALLATION	26
8.1	TRANSPORT & POSITIONING.....	27
8.2	SITING / CLEARANCES	27
8.3	ASSEMBLY	28
8.4	ELECTRIC SUPPLY & CONNECTION.....	28
8.5	COMMISSIONING	29
9.0	SERVICING	30
9.1	CONTROL PANEL REMOVAL.....	31
9.2	ENERGY REGULATOR, SWITCH AND NEON REMOVAL	32
9.3	CONTACTOR REMOVAL	33
9.4	MICRO SWITCH REMOVAL	34
9.5	HEATING ELEMENTS REMOVAL.....	35
9.6	CIRCUIT DIAGRAMS.....	36

9.7	WIRING DIAGRAMS	38
10.0	ACCESSORIES	40
11.0	FAULT FINDING	41
12.0	SPARE PARTS.....	42
13.0	SERVICE INFORMATION.....	43

1.0 SYMBOLS



SCREWDRIVER



SPANNER



COOKING OIL



GREASE



WARNING

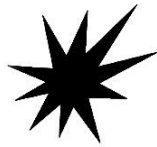

SPARK IGNITION



FLAME



VIEWPORT



ALLEN KEY



IGNITER



C SPANNER



REMOVE DEVICE



PLUG REMOVER

2.0 SAFETY GUIDANCE

2.1 GENERAL SAFETY



2.1.1 These instructions are only valid if the country code appears on the appliance. If the code does not appear on the appliance, refer to the technical instructions for adapting the appliance to the conditions for use in that country.

2.1.2 These appliances have been UKCA/CE-marked based on compliance with the Electrical and Electromagnetic Compatibility (EMC) Regulations/Directives for the Countries as stated on the data plate.



2.1.3 These appliances are for professional use only and must be used by qualified persons.

2.1.4 Never leave these appliances unsupervised when in use and always turn off at the end of service.



2.1.5 The installer must instruct the responsible person(s) of the correct operation and maintenance of these appliances.

2.1.6 Check that no damage has occurred to the appliance or supply cord during transit. If damage has occurred, do not use this appliance.



2.1.7 If fitted to the appliance, ensure the supply cord is routed free from the appliance to avoid damage.



2.1.8 Suitable Protective clothing must be worn when topping up whilst the fryer is hot.

2.1.9 Training and Competence: To help ensure the safe use of these appliances there is a requirement for you to provide whatever information, instruction, training, and supervision as is necessary to ensure, so far as is reasonably practicable, the health and safety of all users.

2.1.10 For further help and information on training and competence we refer you to the Health & Safety Executive website; www.hse.gov.uk document ref: health and safety training INDG345. International customers should default to the health and safety guidelines provided by your government body.



2.1.11 Risk Assessment: As part of managing the health and safety of your business you must control any risks identified in your commercial kitchen. To do this you need to think about what might cause harm to people and decide whether you are taking reasonable steps to prevent that harm. This is known as risk assessment. It is important to consider the environment around the product as well as the product itself. For example, oil or food spills will present a significant risk so users so the need to immediately clean up such spills must be reflected in staff training.

2.1.12 Record the training that you provide and support it by providing safe system of work (SSOW) documents that set out procedures to be followed for potentially hazardous tasks.

2.1.13 For further help and information on risk assessments we would refer you to you the Health and Safety Executive website; www.hse.gov.uk document ref: risk assessment INDG163. International customers should default to the health and safety guidelines provided by your government body.

2.2 INSTALLATION SAFETY



2.2.1 Installation must meet national or local regulations. Attention must be paid to safety (installation & use) regulations, health and safety at work act, local and national building regulations, fire precautions act.

2.2.2 The installer must instruct the responsible person(s) of the correct operation and maintenance of the appliance.

2.2.3 On gas appliances, only competent persons are allowed to service or convert the appliance to another gas type.

2.2.4 Put a documented system in place for periodic inspections, testing and maintenance of our electrical appliances. Check that the fixed electrical installation has been inspected and tested by a competent electrical contractor (e.g. NICEIC-approved or ECA member) as prescribed in BS7671, within the last 5 years.

2.3 ELECTRICAL SAFETY



2.3.1 To prevent shocks, this appliance must be earthed.

2.3.2 This unit is fitted with an equipotential connection at the rear on the base.

2.3.3 Before attempting any maintenance, isolate the appliance from the mains at the switch disconnecter and take steps to ensure that it is not inadvertently switched on.

2.3.4 We recommend supplementary electrical protection with the use of a type A residual current device (RCD).

2.3.5 Fixed wiring appliances incorporate a locally situated switch disconnecter to connect to, which is easily accessible for switching off and safe isolation purposes. The switch disconnecter must meet the specification requirements of IEC 60947.

2.4 FIRE SAFETY



Appliances can present various hazards in the catering environment if not correctly used, operated, and maintained. Hazards including fire, burns from hot oil, contact with hot surfaces, fumes from boiling cleaning chemicals, eye injuries from splashes and slips from oil spillages.

Operator Competency and Training

Ensure you are trained in the safe and proper use of the appliances and know how to turn it off and switch the power off at the mains.

2.4.1 Ensure you are familiar with the kitchen fire safety procedures and the location and proper use of correct fire safety equipment.

Fire Safety Equipment

2.4.2 Provide an appropriate BS compliant fire blanket, and an adequate number of fire extinguishers that comply with BS EN 3 (parts 1-6) and carry a BAFE or LPCB approval mark. At least one must be appropriate for use on electrical fires.

Fire Suppression System

2.4.3 We recommend kitchen equipment and extraction systems are protected with a fire suppression system. Check your insurance as this may also be a condition of your policy.

2.4.4 Protect cooking and extraction equipment (including any associated extraction ductwork and hoods inside the building) by having an extinguishing system installed, in line with (or the equivalent of) [LPS 1223](#). The system should include a local alarm, automatic activation by a detection system and manual activation – located a safe distance away from the cooking equipment, preferably by a fire escape route door.

Operational Safety

2.4.5 Do not leave appliances unattended when powered on or when in use.

2.4.6 Always switch the appliances off when not in use.

Cleaning

2.4.7 Ensure appliances are regularly cleaned. Appliance must be serviced and maintained by a qualified and competent service provider, and there is enough room around the appliance to do so.

2.4.8 Ensure that the appliance, surrounding work area and extraction system are regularly cleaned, (at least weekly) to avoid the build-up of fats oils and greases that could present a fire risk.

2.4.9 A deep clean of the appliance should be undertaken at least every 6 months by a specialist contractor.

Electrical Isolation Points

2.4.10 Ensure any separate electric switches provided for cooking equipment and/or extractor fans are accessible and clearly labelled.

Thermal and Operational Safety Devices

2.4.11 Appliances are fitted with a thermal safety device. This will stop heating of the oven if it becomes overheated. This appliance will always fail safe so long as there is no damage to the thermal safety device.

2.5 MAINTENANCE SAFETY



2.5.1 Unless otherwise stated, parts which have been protected by the manufacturer must not be adjusted by the installer or end user.



2.5.2 Before any cleaning is undertaken, isolate appliance from mains power supply at isolator switch.

2.5.3 Suitable protective clothing must be worn when cleaning this appliance.

2.5.4 The appliance must not be cleaned with a jet of water or steam cleaned. Do not use acid or halogen-based (e.g., chlorine) descaling liquids, flammable liquids, cleaning aids or cleaning powders.

2.5.5 Failure due to lack of proper cleaning is not covered by warranty.



2.5.6 Take care when cleaning not to dislodge or damage thermostat sensors mounted on the base and side of the pan.



2.5.7 If the glass-ceramic hob surface is cracked, smashed or damaged, switch off immediately. Do not use the appliance. Contact Falcon or your approved service provider to undertake the necessary repairs.

2.5.8 To obtain maximum performance from this unit regular servicing of the appliance should be undertaken to ensure correct operation, it is functioning as intended, and safe to use. We recommend servicing in accordance with SFG20 Maintenance Schedules and as a minimum, after 2,500 hours of use, or annually, whichever comes first and that a maintenance contract be arranged with an appointed service contact. Visits may then be made at agreed intervals to carry out adjustments and repairs.





2.5.9 During servicing of the appliance, please check the glass-ceramic hob seal. If the integrity of the seal is compromised, it must be repaired as soon as possible.

3.0 APPLIANCE INFORMATION

The Electric Chargrills are part of the Dominator Plus series of products.

The E3625 is 600mm and the E3925 is 900mm wide. They are controlled by means of an energy regulator.

This appliance has been UKCA/CE marked based on compliance with the relevant Electrical and Electromagnetic Compatibility (EMC) Regulations/Directives for the voltages stated on the data plate.

Falcon Foodservice Equipment   P.I.N STD. 

A Ser No. **B** MODEL **C** TYPE I.P.

	AT, CH, CY, CZ, DK, EE, FI, GR, IT, LT, NO, RO, SE, SI, SK	BE, CH, CY, CZ, ES, FR, GB, GR, IE, IT, LT, PT, SI, SK	DE, PL, RO	AT, BE, CH, CY, CZ, DE, DK, EE, FR, GB, GR, HU, IT, LT, NL, PL, RO, SE, SI, SK	CH, CY, CZ, ES, GB, GR, IE, IT, LT, PT, SI, SK	DE, PL, RO	AT, CH, CY, CZ, DK, EE, ES, FI, FR, GB, GR, IE, IT, LT, LV, NL, NO, PT, RO, SE, SI, SK	BE, CY, ES, FI, FR, GB, GR, IE, PT	BE, CH, CZ, ES, FR, GB, GR, IE, IT, LT, NL, PL, PT, SI, SK
D Cat.	I12H3B/P	I3+	I12E3B/P	I3B/P	I12H3+	I2E	I2H	I3B	I3P
E p mbar	20;30;50	28-30/37	20;30;50	30;50	20;28-30/37	20	20	28-30	37

F GAS TYPE	G20	G30	G31
G GAS RATE	m3/h	kg/h	kg/h
H Σ Qn	KW	KW	kW

I EL. Hz

J Σ kW **K** 

L L1 A L2 A L3 A

A - Serial No

B - Model No

C - Flue Type

D - Gas Category

E - Gas Pressure

F - Gas Type

G - Gas Rate

H - Total Heat Input

I - Electrical Rating

J - Total Electrical Power

K - Magnetic Field Frequency

L - Electrical Phase Loading

4.0 OPERATION

4.1 COMPONENT PARTS

E3625

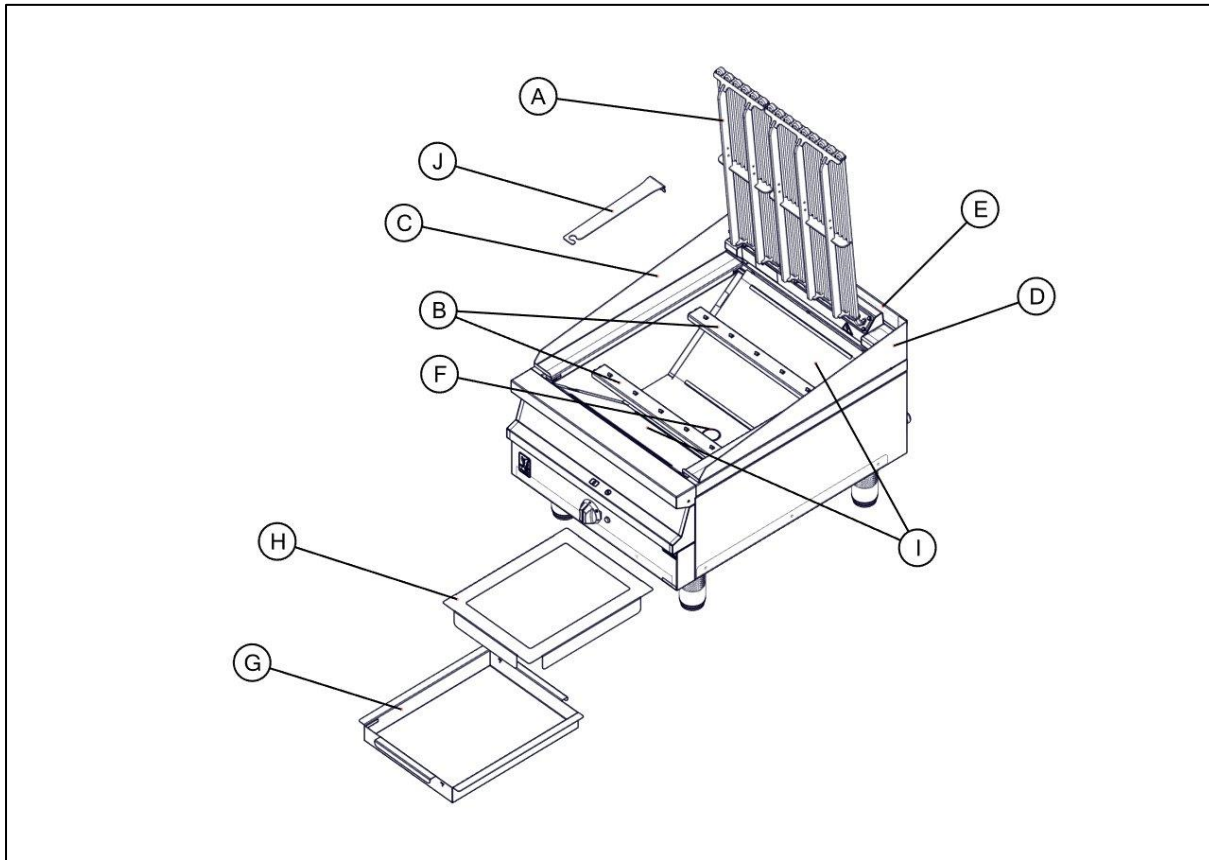

- | | |
|-----------------------------|----------------------|
| A - Element | F- Drain |
| B - Element supports | G- Drip Tray |
| C - Left hand splashguard | H - Drip Tray Insert |
| D - Right hand splashguard | I - PTFE Liners |
| E - Rear splashguard infill | J- Cleaning tool |

E3925

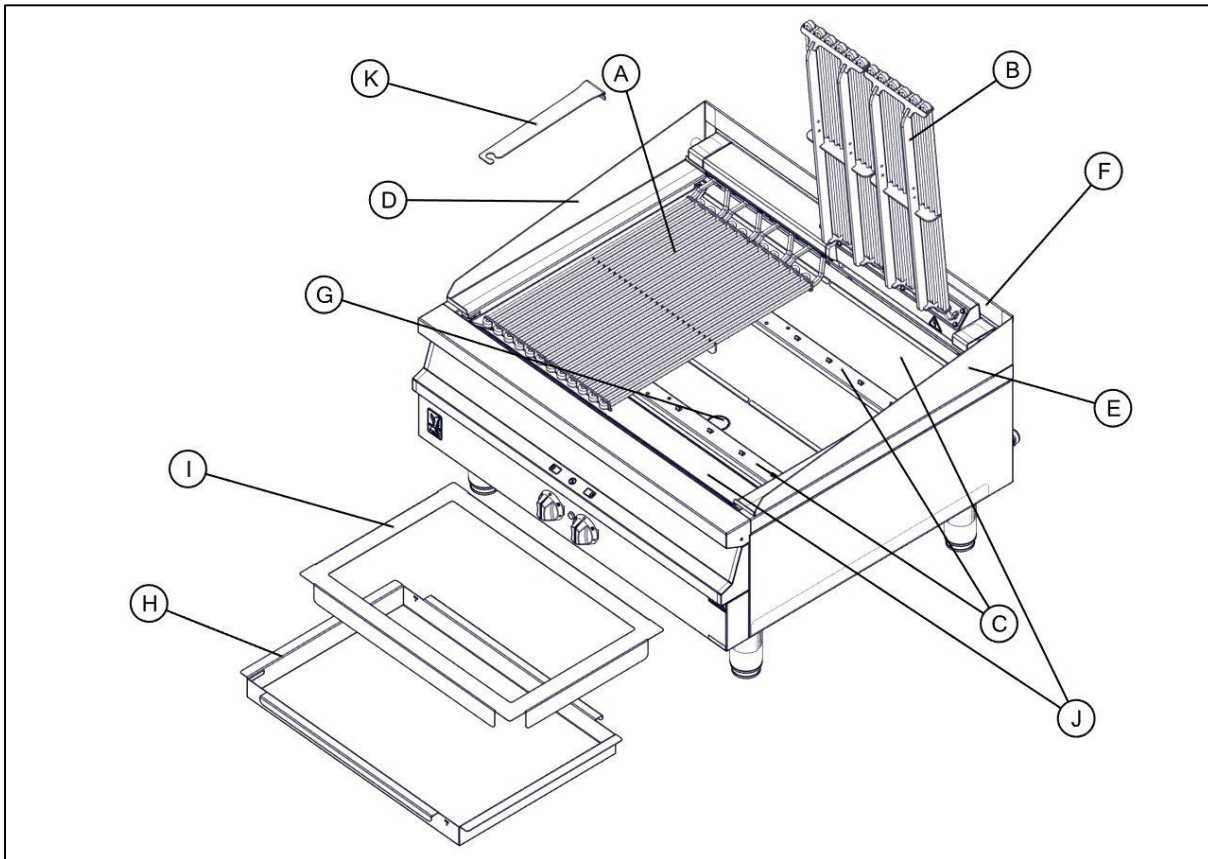

- A - LH Element
- B - RH Element
- C - Element supports
- D - Left hand splashguard
- E - Right hand splashguard
- F - Rear splashguard infill
- G- Drain
- H- Drip tray
- I- Drip Tray Insert
- J- PTFE Liners
- K- Cleaning tool

4.2 CONTROLS

E3625

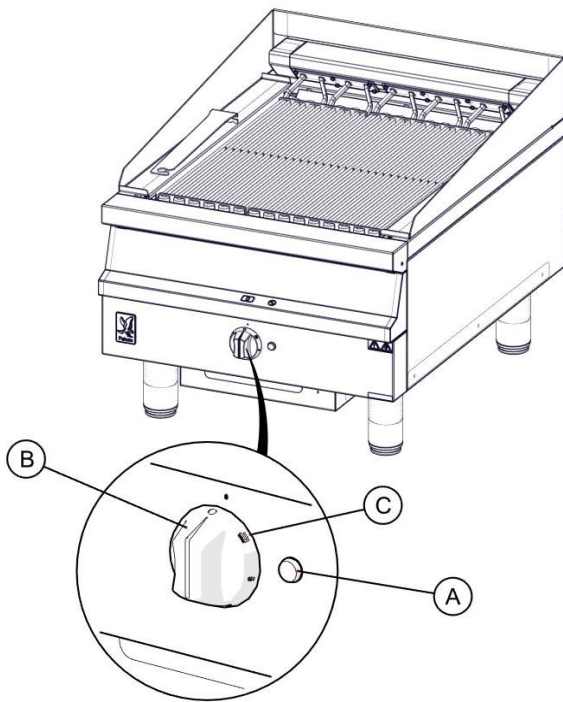

- A - Power neon (Red)
- B - Control
- C - Cleaning setting

E3925

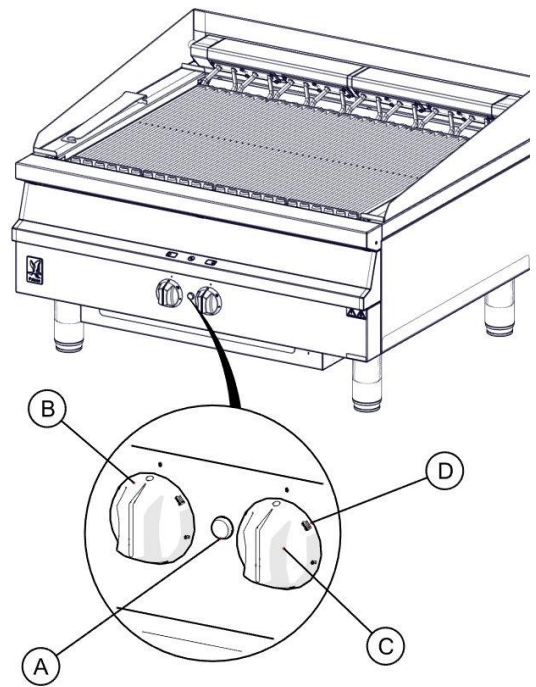

- A- Power neon (Red)
- B- Left hand control
- C- Right hand control
- D- Cleaning setting

4.2.1 The appliance control knob is marked with a numbered indicator to indicate regulator settings.

4.2.2 The dial should rotate clockwise from setting 1 to 5 and stop.



Dial setting 5

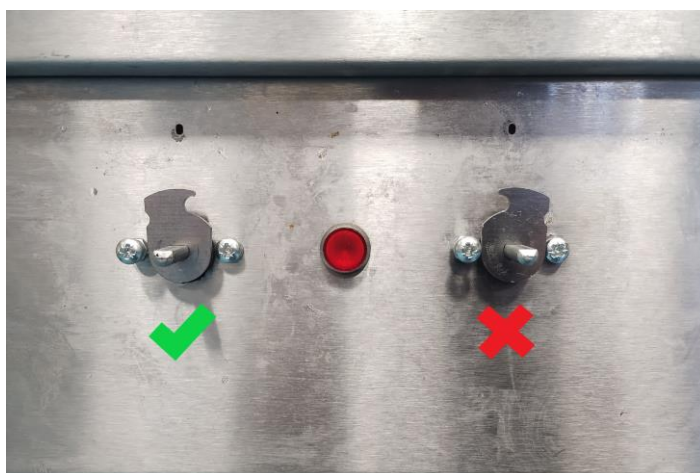

Dial Control knob stops

4.2.3 If it does not turn clockwise and stop at setting 5 check that the control knob stop is fitted correctly.

4.2.4 The dial should turn anticlockwise and stop at the Brush symbol in line with the mark. If it does not check that the control knob stop is fitted correctly.

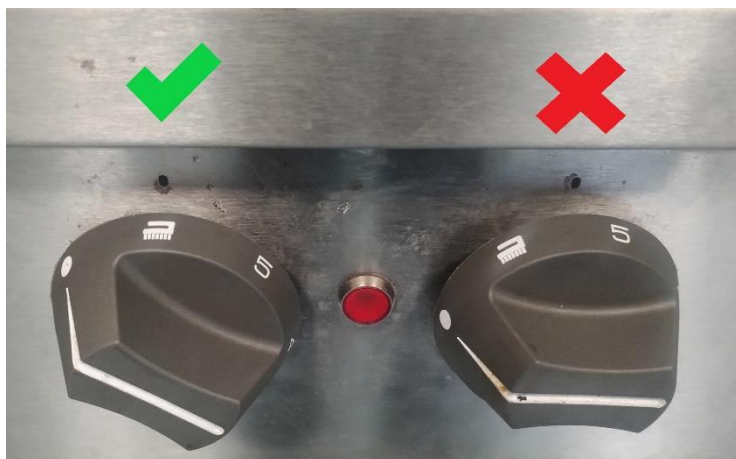

Cleaning setting

4.2.5 The brush setting on the control knob is used for cleaning only. At this position, the elements can reach 400°C

4.2.6 Red neon located on the control panel indicates that electricity is being supplied, i.e. the isolating switch is ON and the chargrill is ready for use.

4.3 USING THE APPLIANCE

4.3.1 Before use, clean the appliance inside and out. See section 5.

4.3.2 Ensure the drip tray is fitted.

4.3.3 Power Neon (red) will light when there is mains power to the appliance.

4.3.4 The appliance is fitted with a numbered control knob which indicates regulator setting.



THE CLEAN SETTING IS USED FOR CLEANING ONLY, IN THIS POSITION THE ELEMENTS CAN REACH 400°C.



DO NOT LEAVE THE CHARGRILL RUNNING ON A HIGH SETTING FOR PROLONGED PERIODS WHEN NOT COOKING.

TO MAINTAIN ELEMENT HEAT, TURN THE CONTROL TO A LOWER SETTING.

4.4 CHEF'S RECOMMENDATIONS

4.4.1 Element temperature must be regulated for different circumstances.

4.4.2 The food absorbs heat from the elements, when the chargrill is in continuous use and cooking large quantities of food, it may be necessary to turn the control to a higher setting than is normally required for smaller batches

4.4.3 **Lightly oil** the food item that is being cooked, prior to placing it on **the pre-heated element**.

4.4.4 Keep grill elements clean for best performance.



DO NOT PLACE NON-FOOD OBJECTS ON ELEMENTS, INCLUDING METALLIC OBJECTS FOR EXAMPLE; POTS, PANS OR UTENSILS AS THIS MAY CAUSE OVERHEATING OF THE ELEMENTS AND LEAD TO A NON-WARRANTY FAILURE.

5.0 CLEANING AND MAINTENANCE

When removing heavy items to aid cleaning or maintenance particular care should be taken. A manual handling risk assessment is the best way to determine the level of risk to anyone using or maintaining this equipment. To help with such an evaluation we have included the weights of individual components that may present significant risk.

For further help and information on manual handling and associated risk assessment we would refer you to you the Health and Safety Executive website; www.hse.gov.uk document ref: manual handling at work INDG143. International customers should default to the health and safety guidelines provided by your government body.

The cleaning of fryers or other products that use hot oil present significant risks to end users and particular care should be taken. Cold water and hot oil for example are an explosive mix and should be avoided at all costs.

Other useful references for health and safety issues:

- www.hse.gov.uk
- Essentials of health and safety at work ISBN978
- Noise at work INDG362
- Safe systems of work
- Other notes added to the body of the instructions

BEFORE ANY CLEANING IS UNDERTAKEN, ISOLATE THE APPLIANCE FROM MAINS POWER SUPPLY AT ISOLATOR SWITCH.



SUITABLE PROTECTIVE CLOTHING MUST BE WORN WHEN CLEANING THIS APPLIANCE.

THE APPLIANCE MUST NOT BE STEAM CLEANED. DO NOT USE ACID OR HALOGEN-BASED (E.G. CHLORINE) DESCALING LIQUIDS, FLAMMABLE LIQUIDS, CLEANING AIDS OR CLEANING POWDERS.

FAILURE DUE TO LACK OF PROPER CLEANING IS NOT COVERED BY WARRANTY.

MAINTENANCE CHECK



Regular servicing of the appliance should be undertaken to ensure correct operation, it is functioning as intended, and safe to use. We recommend servicing after 2,500 hours of use, or annually, whichever comes first.

Any maintenance schedule should be carried out in accordance with SFG20 Maintenance Schedule. Should any issues with the integrity of the components be identified these should be replaced. If the appliance is not considered safe the unit should be removed from service and the responsible person advised why the unit is not safe to use and what remedial action is needed. Contents of the maintenance schedule should be agreed with the maintenance provider

NOTE: All surfaces are easier to clean if spillages are removed before becoming burnt on, and the appliance is cleaned daily.

It should be noted that certain scouring pads including nylon types can easily mark stainless steel. Care should be exercised during cleaning process. When rubbing stainless steel with a cloth, always rub in the direction of the grain.

5.1 CLEANING AND MAINTENANCE

5.1.1 Ensure the unit is completely turned off at the mains.

5.1.2 Remove any pieces of large debris from the elements using the tool provided.

5.1.3 Raise elements, and lift from the front close to the element support bar using the tool provided. Lift up to the vertical position until the elements engage the element securing pins to lock them in place.

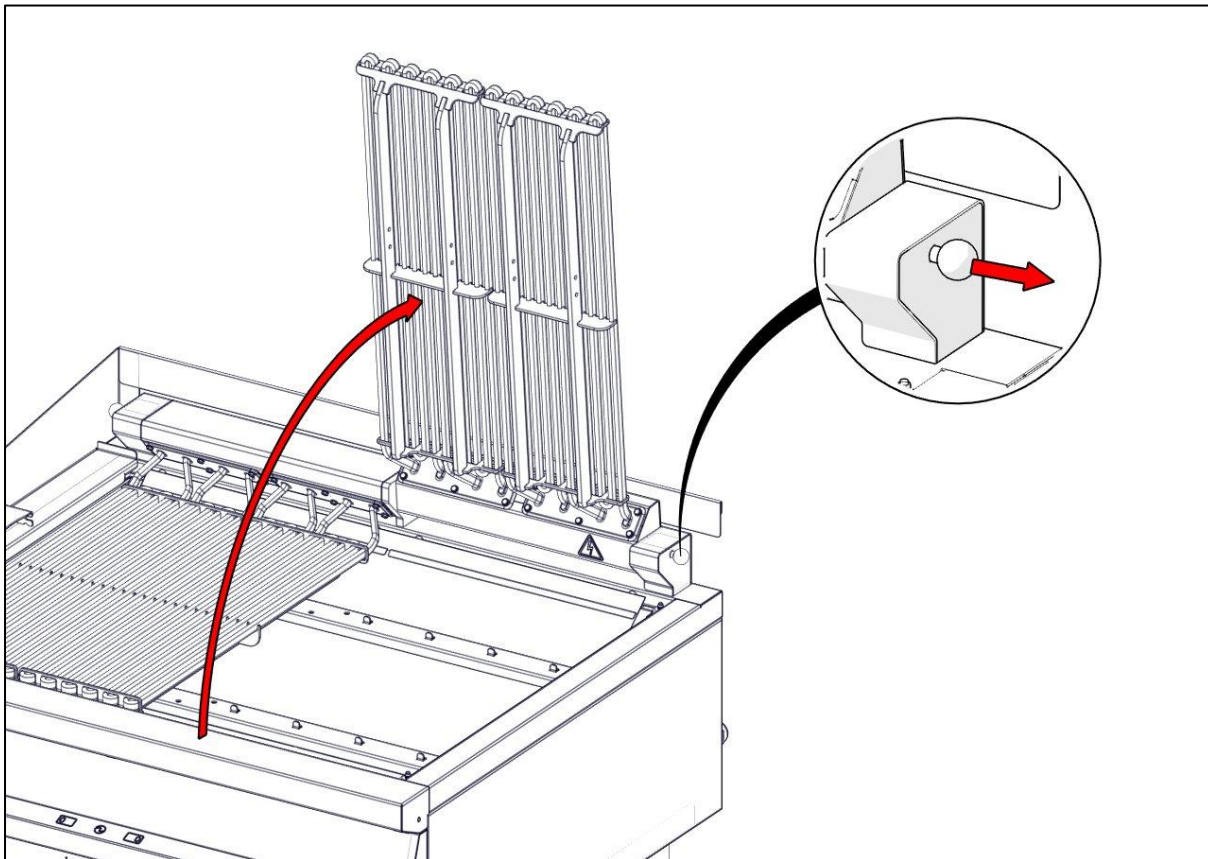

- 5.1.4 If Reflector plates are fitted to the appliance remove and clean in a dishwasher or in a sink using a cloth with hot soapy water.
- 5.1.5 Remove any pieces of large debris from the underside of the elements, using the tool provided, and from the element support bars.
- 5.1.6 Lower the elements back to the horizontal position.
- 5.1.7 Turn the control knob to the cleaning setting.
- 5.1.8 Allow to run at maximum temperature for approximately 15 minutes.
- 5.1.9 At this setting most food debris should carbonize and fall off the elements.
- 5.1.10 Scrape off any remaining debris using the element cleaning tool provided.
- 5.1.11 Ensure the unit is completely turned off at the mains.
- 5.1.12 When cold the elements may also be cleaned using a cloth and hot soapy water. The same method of cleaning is required for the support bars and underneath the elements. This is to be conducted between services or at the end of the day.
- 5.1.13 Lift the elements to the vertical position and **engage locking pin**.



ENSURE THE ELEMENTS ARE COLD BEFORE RAISING



ENSURE LOCKING PIN IS ENGAGED AND HOLDING ELEMENTS UPRIGHT BEFORE CLEANING.

- 5.1.14 Clean the pan with warm water and detergent.
- 5.1.15 To clean the drip tray remove it from the appliance and warm water and detergent.
- 5.1.16 The splash guard is removable for cleaning.
- 5.1.17 The front and rear element support bars are also removable for cleaning.



DO NOT USE COARSE ABRASIVES TO CLEAN EXTERIOR PANELS. WARM WATER AND DETERGENT SOLUTION IS RECOMMENDED.

5.1.18 To lower elements disengage locking pin and lower as required.

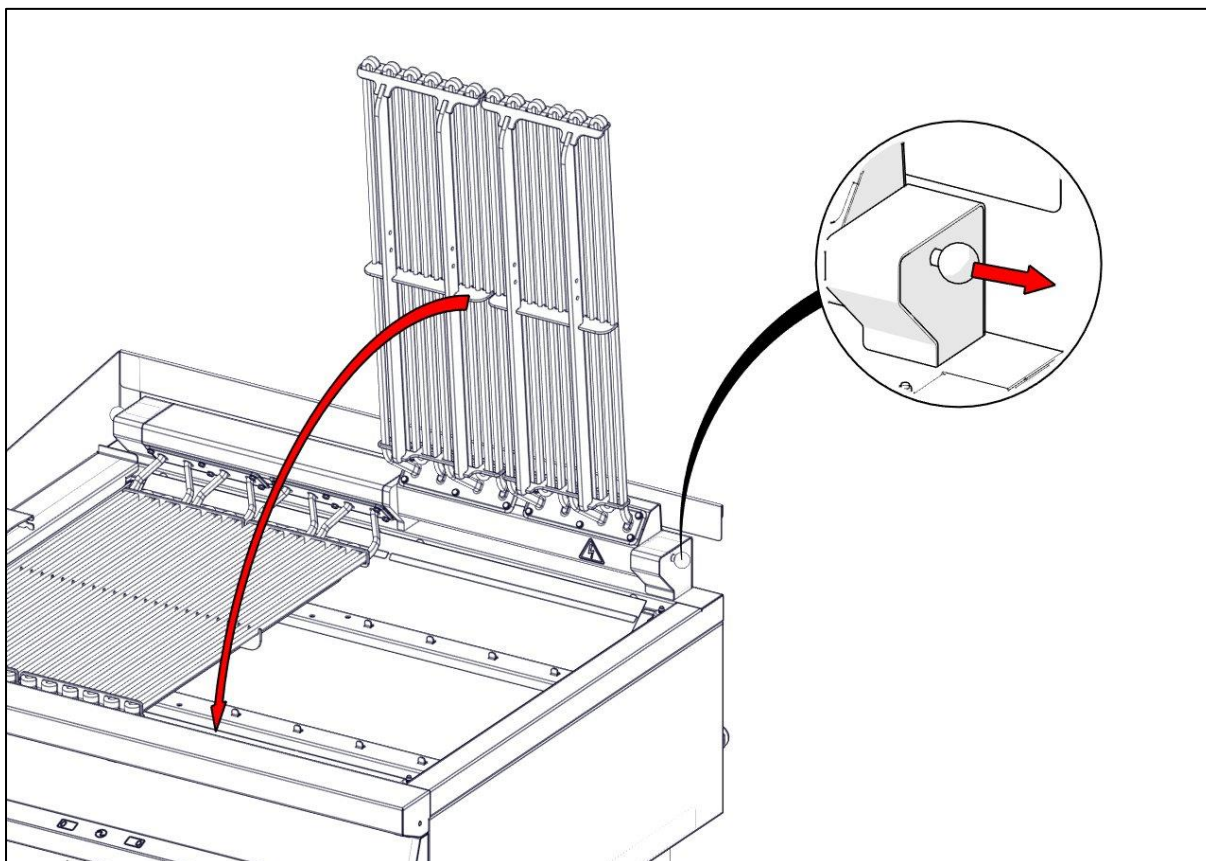

DO NOT FORCE ELEMENTS DOWN WHILST LOCKING PIN IS ENGAGED. DOING THIS WILL DAMAGE THE MECHANISM.

5.1.19 If the unit is fitted with PTFE liners, ensure any debris that has collected behind the liners is removed daily.



THE PTFE SHEET SHOULD NOT BE ALLOWED TO COME INTO CONTACT WITH THE ELEMENTS WHEN HOT.

5.1.20 The PTFE sheeting should be cleaned using non-corrosive agents. Warm water and detergent is recommended.



DO NOT USE SHARP OR ABRASIVE MATERIALS TO CLEAN THE PTFE SHEETING.

DISHWASHING THE PTFE SHEETING IS NOT RECOMMENDED.

5.2 PTFE LINER REMOVAL FOR CLEANING

5.2.1 Remove Splashguards and raise element(s) to vertical and engage locking pin.

5.2.2 Remove assembled PTFE Liner frames.

5.2.3 The cleaning of the PTFE sheeting may be carried out using non-corrosive agents, warm water, and detergent is recommended.

5.2.4 At no point should sharp or abrasive material be used to clean the sheeting, this will damage the material.

5.2.5 Dishwashing the PTFE is not recommended.

5.2.6 Re-fit PTFE liners, elements and splash guards when finished cleaning

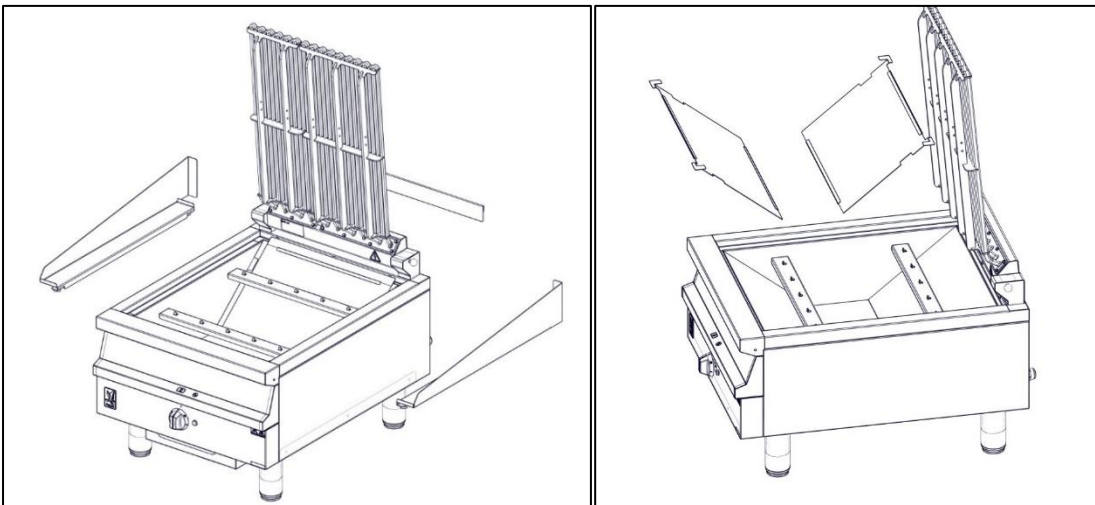

5.3 PTFE SHEET REMOVAL

5.3.1 Follow the steps in 5.2 to remove the PTFE Liner frame.

5.3.2 Remove the metal retaining clips (A) from the top and bottom edges of the liner mounting board (B). The PTFE sheet (C) will now be loose and can be removed.

5.3.3 To re-install the PTFE sheet (C), position it on the mounting plate (B), ensuring equal overlap to the rear of the mounting plate (B).

5.3.4 It is advised to secure one side of the PTFE sheet (C) initially then make sure that the PTFE sheet (C) is taught before installing the edge clip (A) on the opposite side. Repeat the process again with the remaining parts.

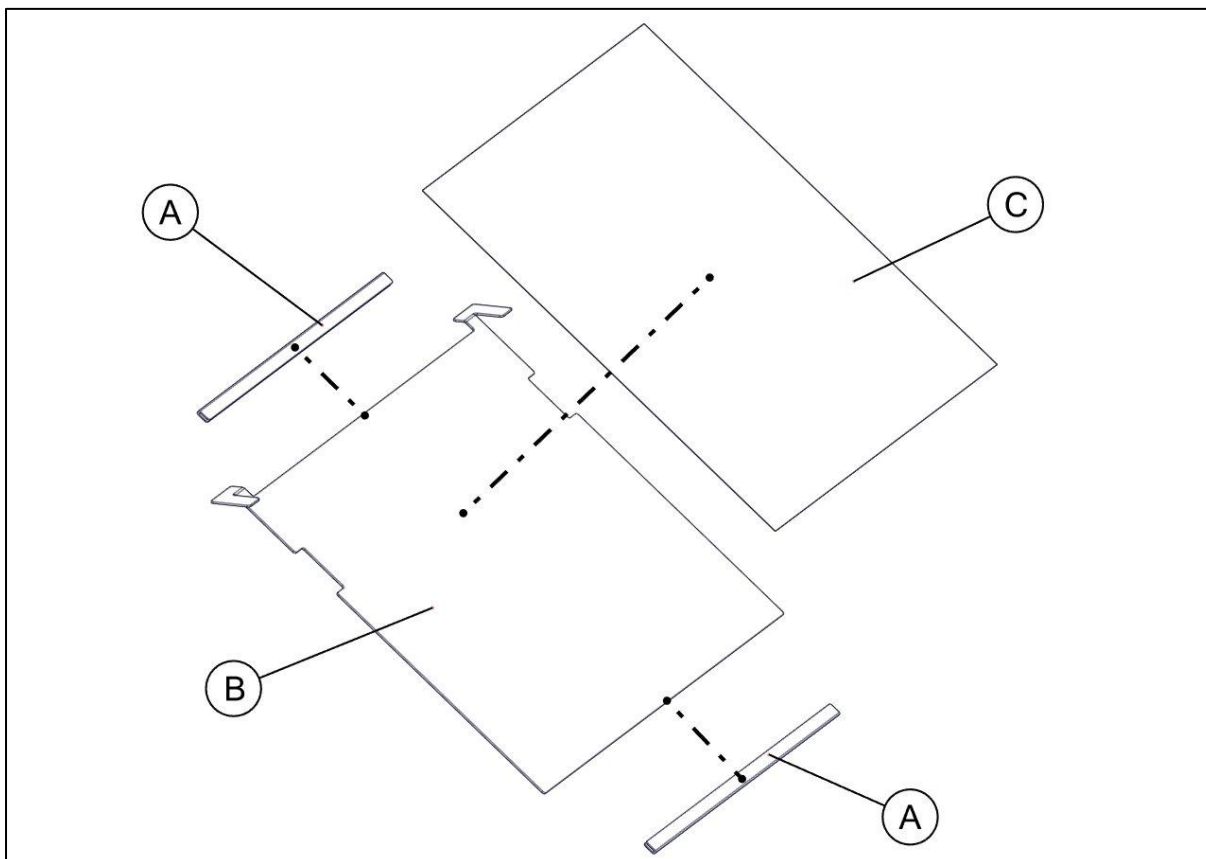

6.0 SPECIFICATION

6.1 APPLIANCE WEIGHT TABLE

APPLIANCE	UNIT WEIGHT (kg)	PACKED WEIGHT (kg)
E3625	56.5	68.7
E3925	75.5	88.7

6.2 TECHNICAL DATA TABLE

E3625	CURRENT			POWER
PHASE	MIN (A) @ 230V	MAX (A) @ 230V	Nominal (A) @ 230V	Nominal (kW) @ 230V
L1	10.00	11.67	11.11	3.36
L2	13.09	15.28	14.55	3.36
L3	10.00	11.67	11.11	1.68

E3925	CURRENT			POWER
PHASE	MIN (A) @ 230V	MAX (A) @ 230V	Nominal (A) @ 230V	Nominal (kW) @ 230V
L1	13.09	15.28	14.55	3.36
L2	20.00	23.33	22.22	6.72
L3	20.00	23.33	22.22	3.36



IF ANY CURRENT IS OUT WITH THESE TOLERANCES, THE CAUSE MUST BE INVESTIGATED AND RECTIFIED.

7.0 DIMENSIONS / CONNECTION LOCATIONS

E3625

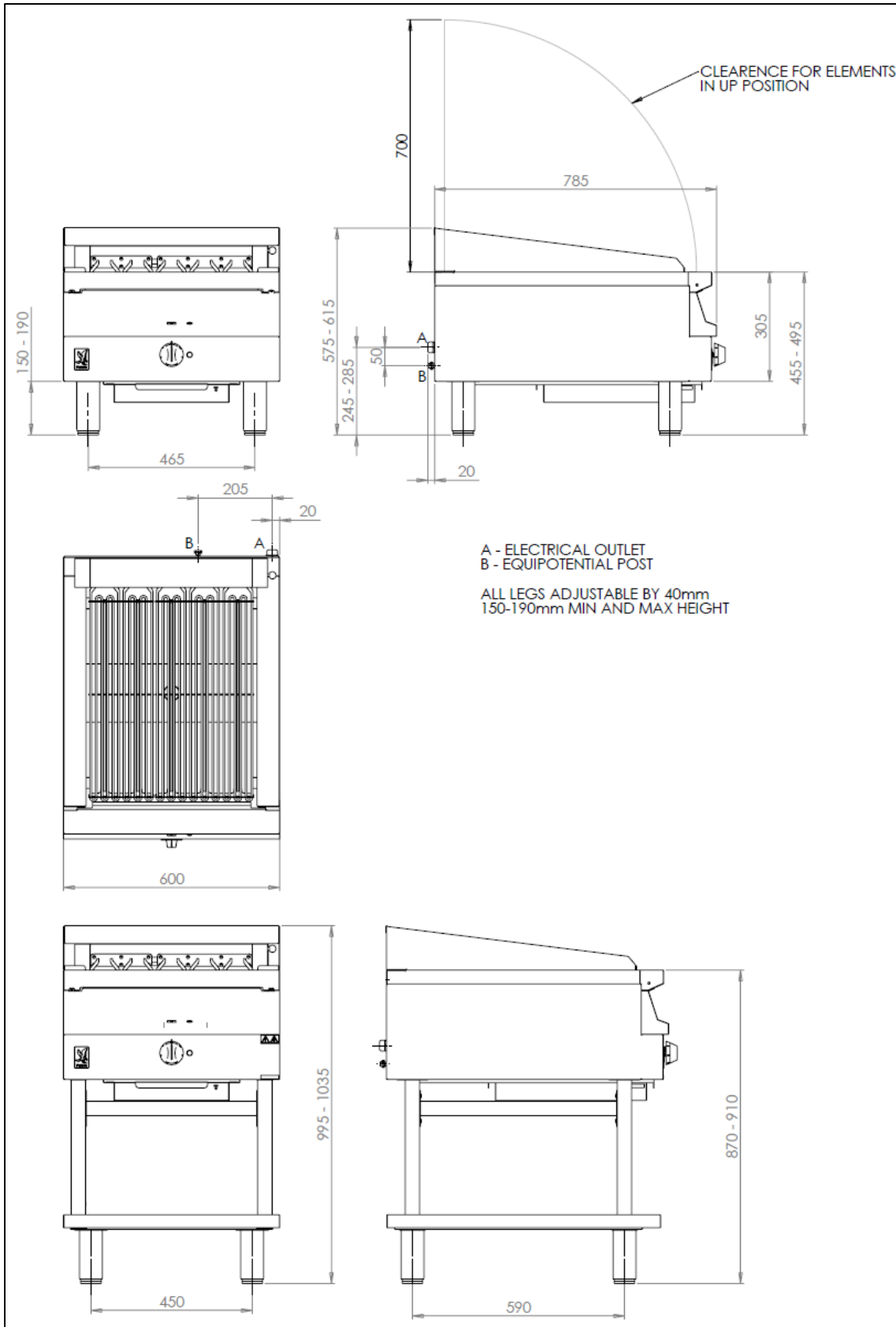

E3925

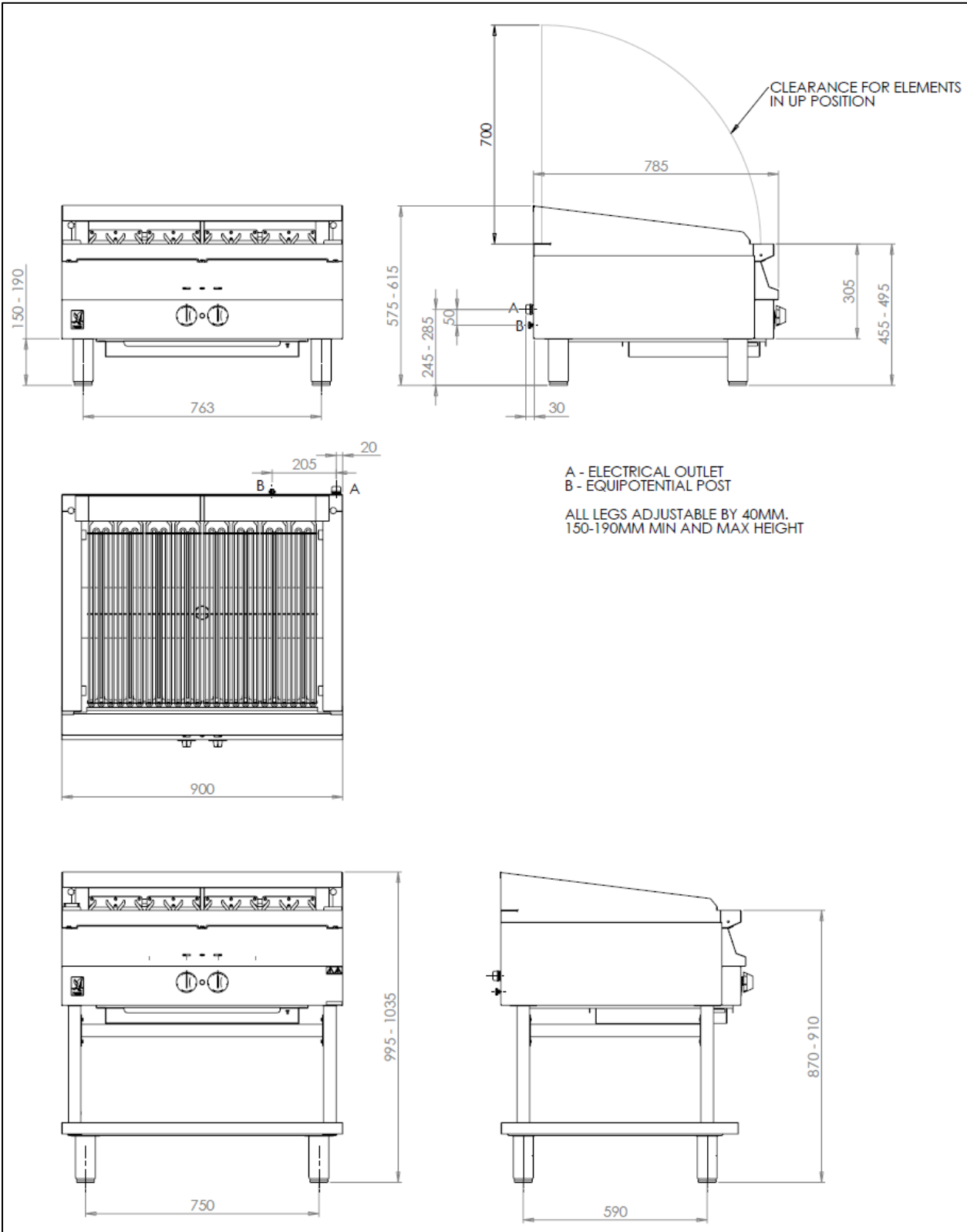

8.0 TRANSPORTATION & INSTALLATION

ELECTRICAL SAFETY AND ADVICE REGARDING SUPPLEMENTARY ELECTRICAL PROTECTION

Commercial kitchens and foodservice areas are environments where electrical appliances may be located close to liquids or operate in and around damp conditions or where restricted movement for installation and service is evident.

The installation and periodic inspection of the appliance should only be undertaken by a qualified, skilled and competent electrician; and connected to the correct power supply suitable for the load as stipulated by the appliance data label.

The electrical installation and connections should meet the necessary requirements to the local electrical wiring regulations and any electrical safety guidelines.

We recommend:

- Supplementary electrical protection with the use of a type A residual current device (RCD)
- Fixed wiring appliances incorporate a locally situated switch disconnector to connect to, which is easily accessible for switching off and safe isolation purposes. The switch disconnector must meet the specification requirements of IEC 60947.

Your attention is drawn to:

BS 7671:2018—Guidance Note 8 - 8.13: Other locations of increased risk.

It is recognized that there may be locations of increased risk of electric shock other than those specifically addressed in Part 7 of BS 7671. Examples of such locations could include laundries where there are washing and drying machines in close proximity and water is present, and commercial kitchens with stainless steel units, where once again, water is present.

Where because of the perception of additional risks being likely, the installation designer decides that an installation or location warrants further protective measures, the options available include:

- Automatic Disconnection of Supply (ADS) by means of a residual current device having a residual operating current not exceeding 30mA;
- Supplementary protective equipotential bonding; and
- Reduction of maximum fault clearance time.

The provision of RCDs and supplementary bonding must be specified by the host organization's appointed installation designer or electrical contractor and installed by a suitably qualified and competent electrician so as to comply with Regulations 419.2 and 544.2.

8.1 TRANSPORT & POSITIONING

General warnings for transport:

- a) Observe the maximum load and stacking limits.
- b) Follow the indications shown on the packaging, any instructions on the equipment, including those on the points where forklift trucks cannot be used.
- c) Danger of crushing during transportation due to the weight of the appliance.
- d) Hands and fingers may be crushed.
- e) Wear suitable protective clothing when transporting.
- f) Danger of overturning during transporting
- g) Danger of crushing due to the appliance overturning on persons.
- h) Take care over the centre of gravity of the appliance.
- i) Take great care to ensure that the appliance does not overturn during transportation, lifting and after installation.

Take care over the width and height of accesses during transportation.

Take care not to damage the appliance due to narrow doorways: doorways less than 80cm wide, remove any handles etc.

Check that all the parts of the appliance are intact and have not been damaged during transportation. If damaged due to transportation, inform the specialised reseller/ haulier immediately.

To position the appliance, it is recommended to use the mount offered by the manufacturer, should you want to do things differently, it is necessary to take account of the weight of the appliance.

Before permanently fixing the appliance in position, the Water, Electrical and Gas Connections must be made. (See relative sections).

Once the appliance is installed, the electrical power cable must be protected, and never stretched or tugged.

Remove all packaging materials and peel away the protective plastic film from all external surfaces of the appliance.



UNLESS OTHERWISE STATED, PARTS WHICH HAVE BEEN PROTECTED BY THE MANUFACTURER ARE NOT TO BE ADJUSTED BY THE INSTALLER.

Please ensure that any plastic coatings are removed prior to use. Before operation, the pan requires to be thoroughly cleaned and dried.

Discolouration of heated parts is caused by factory testing to ensure a satisfactory unit. It does not affect quality or performance.

8.2 SITING / CLEARANCES

This appliance cannot be sited next to a combustible wall.



IF SUITING, THE NECESSARY CLEARANCES TO ANY COMBUSTIBLE WALL MUST BE THE LARGEST FIGURE GIVEN FOR INDIVIDUAL APPLIANCE INSTRUCTIONS.

8.3 ASSEMBLY

8.3.1 Position the appliance and level using feet adjusters as shown below.

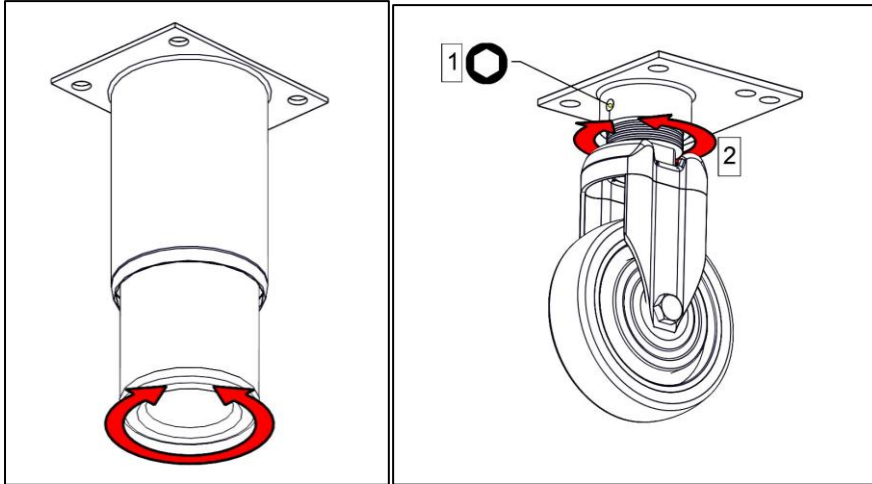

TAKE CARE WHEN MOVING AN APPLIANCE FITTED WITH CASTORS.

8.4 ELECTRIC SUPPLY & CONNECTION

The location of the electrical inlet is as seen in section 5.0. This unit is suitable for AC supplies only. The standard terminal arrangement is Three phase (400V 3N~) for all variants.

Live 1 (Phase 1)	Brown
Live 2 (Phase 2)	Black
Live 3 (Phase 3)	Grey
Neutral	Blue
Earth	Yellow/Green

A mains input connecting cable is not supplied. A suitable cable should be provided by the installer. Install an appropriate three phase mains supply cable with a 32A plug.

To install the mains cable, remove rear access panel as shown in section 7.1 and feed the cable through and connect to the terminal block.



THIS APPLIANCE MUST BE EARTHED

8.5 COMMISSIONING

Refer to section 4.0 for operation. Carry out the following operation:

8.5.1 Turn on mains power supply on.

8.5.2 Ensure red neon illuminates.

8.5.3 Turn control knob to the clean setting.

8.5.4 Let the appliance heat up. At this setting the chargrill is constantly on and can reach temperatures up to 400°C.

8.5.5 Switch appliance off.

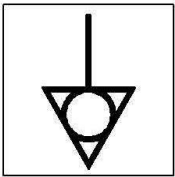

This appliance is also provided with a terminal for connection of an external equipotential conductor. This terminal is an effective electrical contact with all fixed exposed metal parts of the appliance and shall allow the connection of conductor having a nominal cross-section area of up to 10mm². It is located at the rear of the unit and identified by the following label and must only be used for bonding purposes.

8.5.6 If the appliance does not operate correctly, please refer to section 9.0 and rectify the problem.



PLEASE FILL OUT THE INFORMATION TABLE ON THE FRONT COVER AFTER COMMISSIONING.

9.0 SERVICING



BEFORE ATTEMPTING ANY MAINTENANCE, ISOLATE THE APPLIANCE AT THE MAINS SWITCH AND TAKE STEPS TO ENSURE THAT IT IS NOT INADVERTENTLY SWITCHED ON.

THERE ARE NO SERVICEABLE COMPONENTS LOCATED IN THE ELEMENT HEAD. THE MICRO SWITCH IS LOCATED IN THE PIVOT HOUSING OF THE ELEMENT ASSEMBLY AS SHOWN IN STEP 7.5.



THE ELEMENT HEAD IS A NON SERVICEABLE COMPONENT. REMOVING THE ELEMENTS FROM THE ELEMENT HEAD OF THE APPLIANCE WILL UNSEAT THE GASKET. THIS WILL LEAD TO THE INGRESS OF FOOD AND GREASE DEBRIS INTO THE ELEMENT HEAD ASSEMBLY.

IF THERE IS A FAULT WITH THE ELEMENTS ON THE APPLIANCE THE COMPLETE ELEMENT HEAD ASSEMBLY SHOULD BE REPLACED AS INSTRUCTED BELOW IN STEP 7.6.

DO NOT LOOSEN OR REMOVE THESE SCREWS OR BOLTS

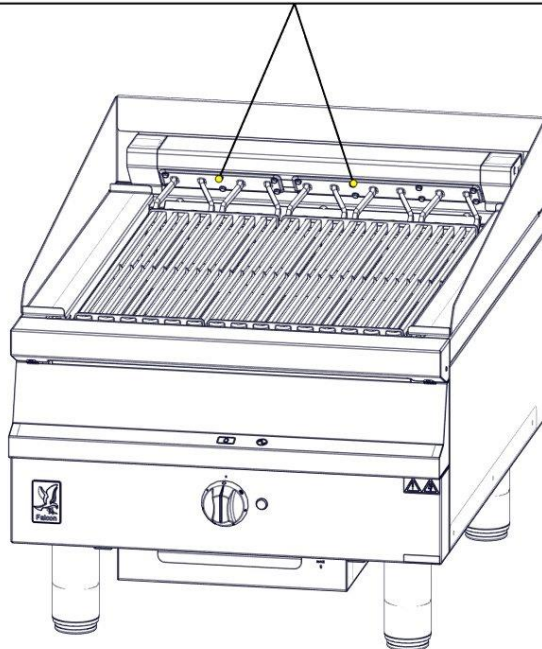

9.1 CONTROL PANEL REMOVAL

9.1.1 Remove control panel as shown below.

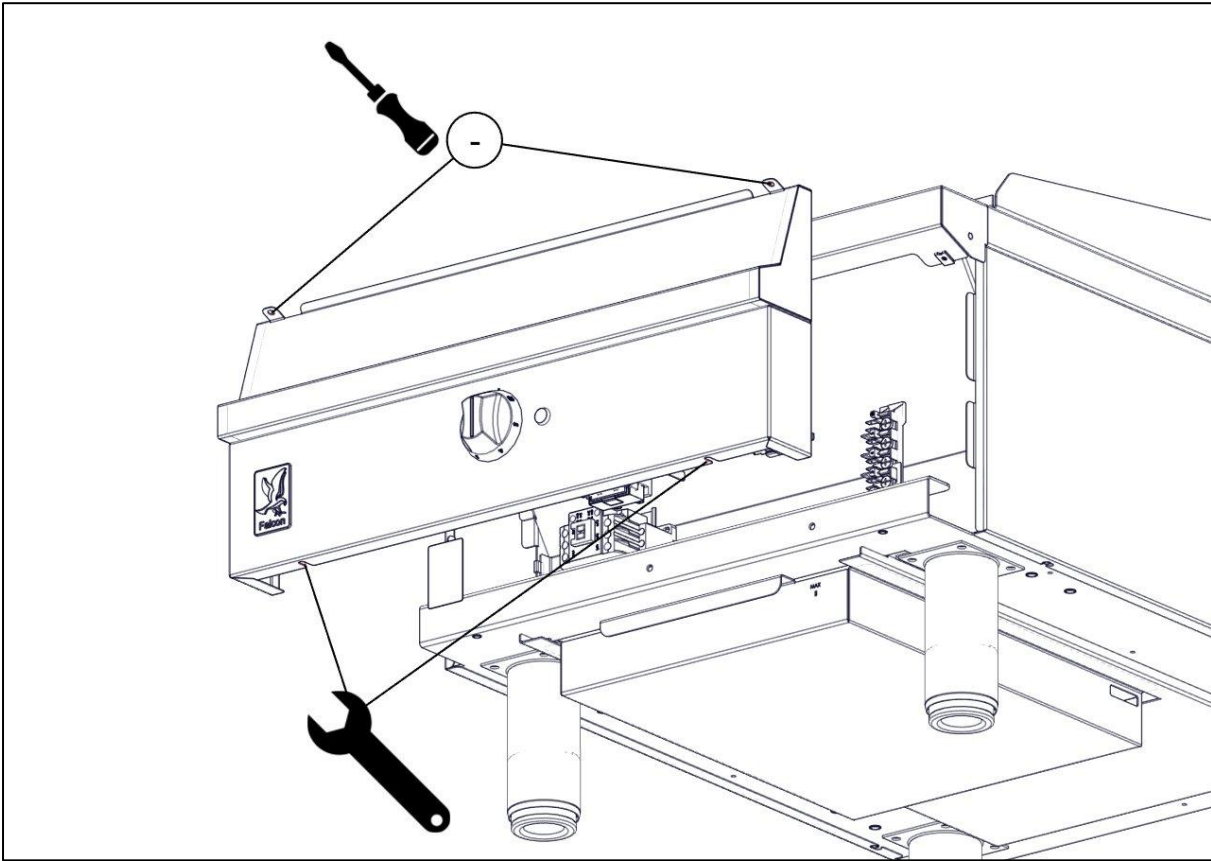

9.2 ENERGY REGULATOR, SWITCH AND NEON REMOVAL

9.2.1 Remove control panel as shown in section 9.1.1

9.2.2 Remove energy regulator and switch as shown below.

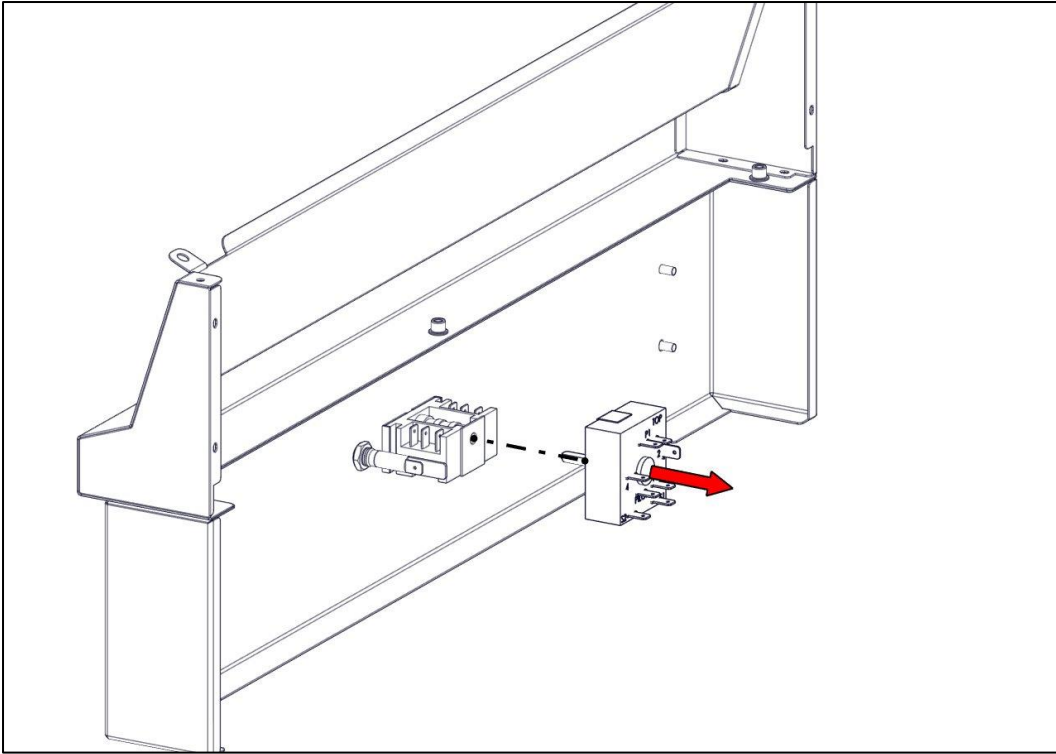

9.2.3 Remove switch as shown below

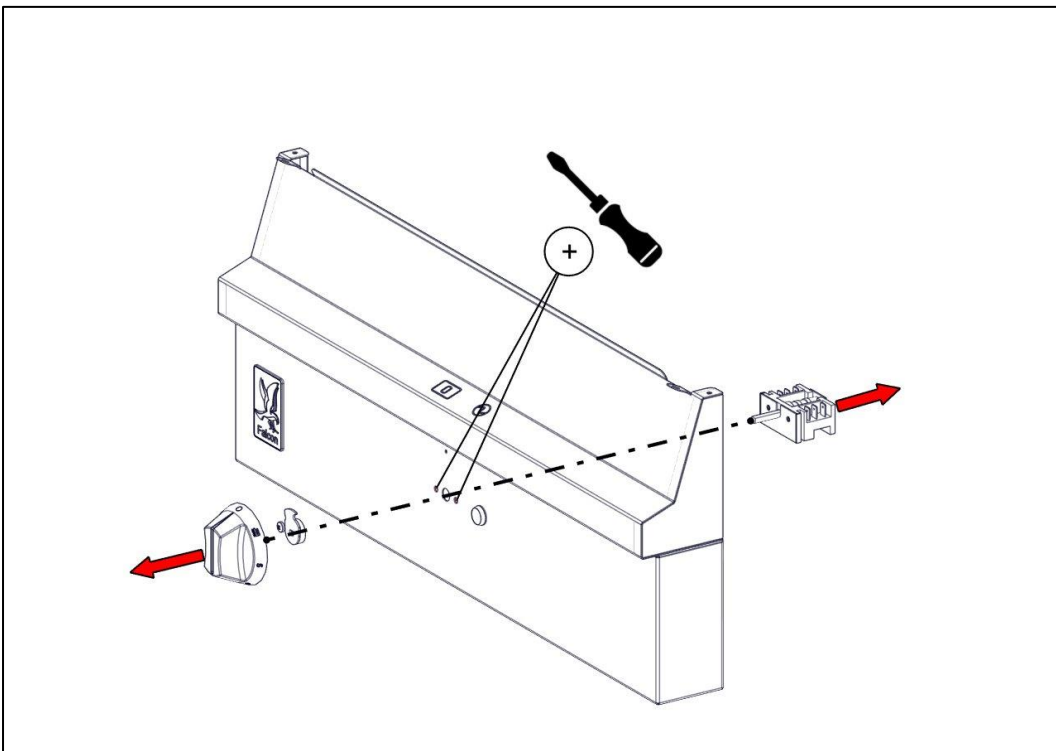

Note: When replacing the switch ensure the control knob and stop are correctly fitted as shown on page 15.

9.2.4 Remove neon as shown below.

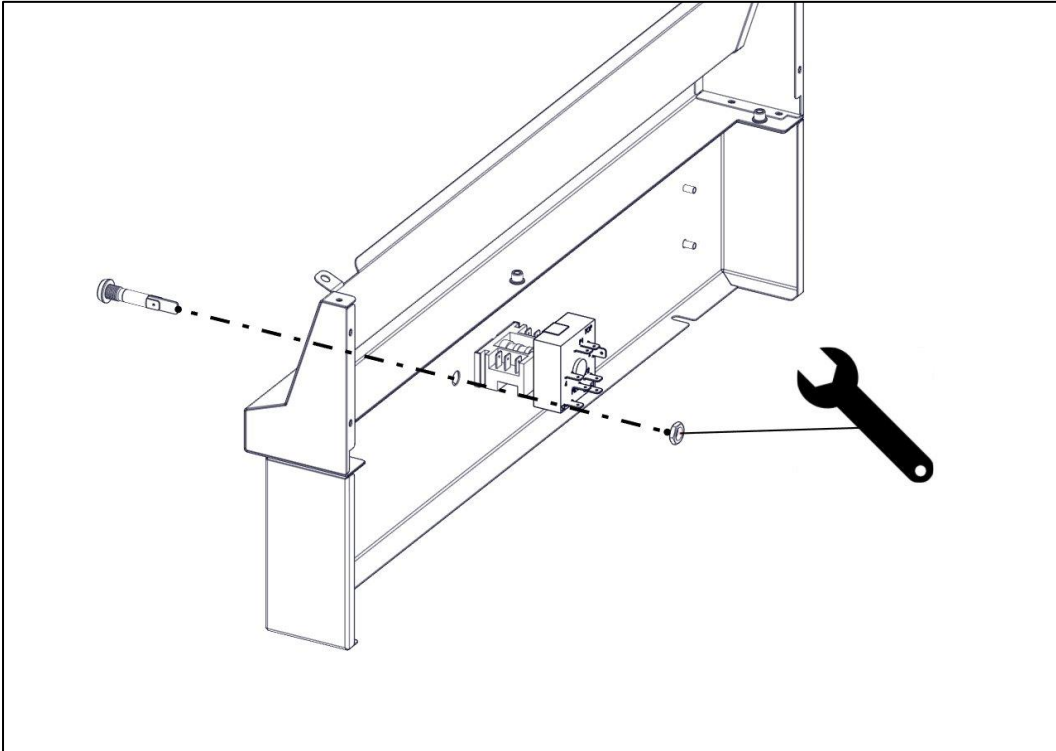

9.3 CONTACTOR REMOVAL

9.3.1 Remove control panel as shown in section 9.2.1

9.3.2 Remove contactor as shown below.

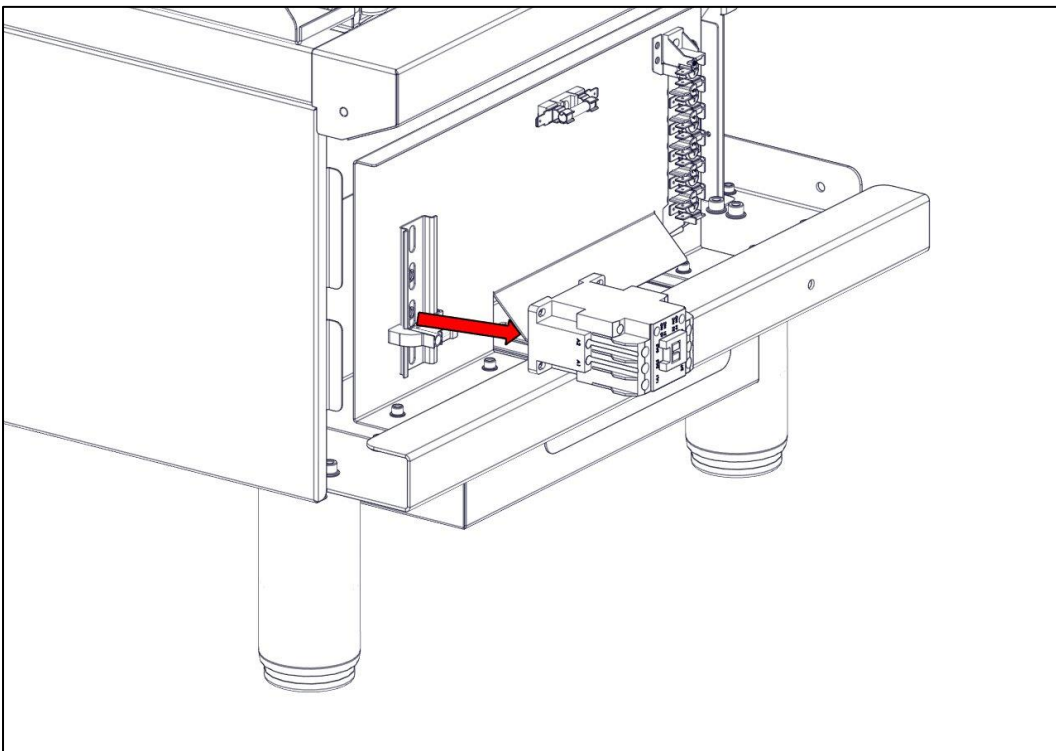

9.4 MICRO SWITCH REMOVAL

9.4.1 Remove splashguards and rear panel as show below

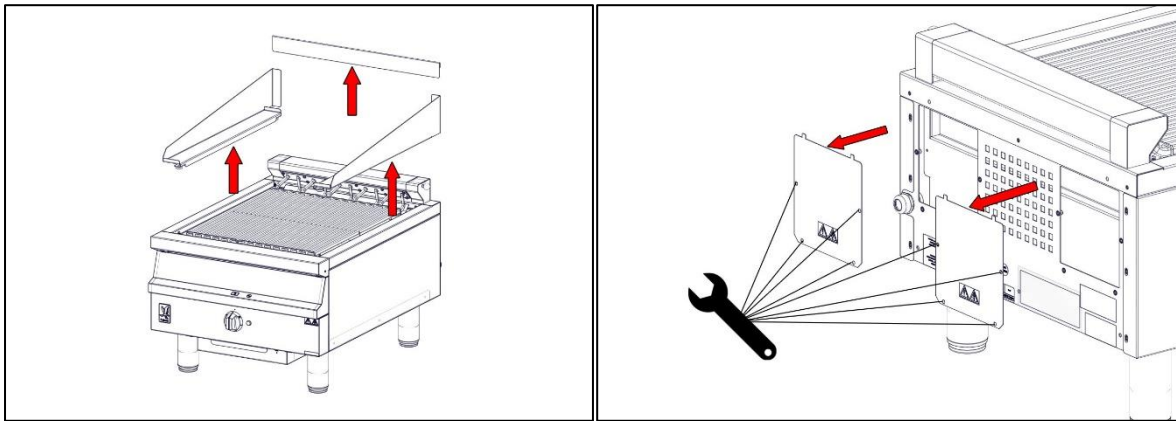

9.4.2 Remove two hex screws from each side of underside of the hob. Pull back pin and remove element head end covers from the topside of hob and repeat on opposite side if required.

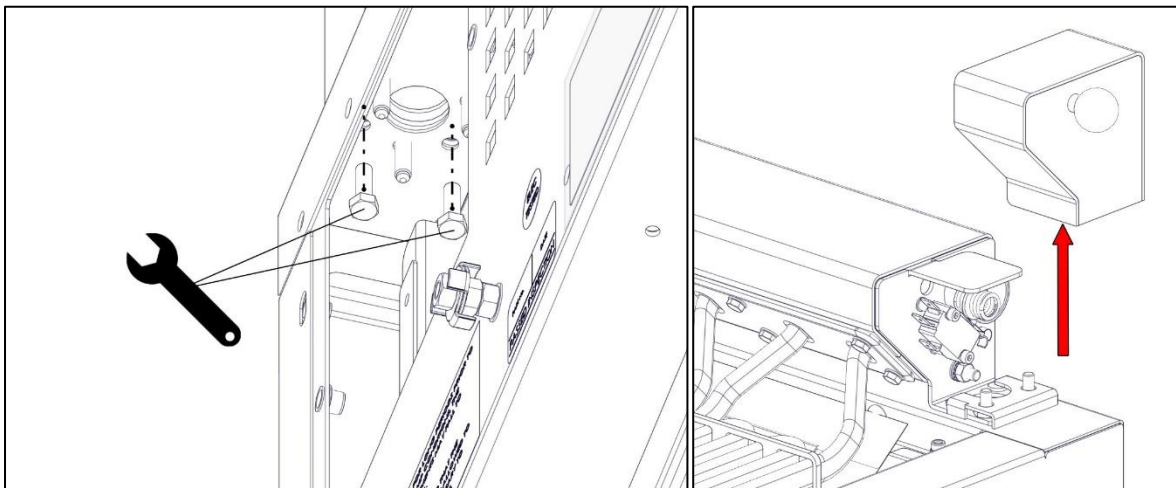

9.4.3 Disconnect the wires from micro switch and unfasten two cap screws to remove micro switch.

9.5 HEATING ELEMENTS REMOVAL

9.5.1 Remove splashguard, rear panel and element head end covers as shown in section 9.4.1 and 9.4.2.

9.5.2 Remove control panel as shown in section 9.2.1.

9.5.3 Remove element wires from contactor(s).

9.5.4 Remove three hex nuts on each end of the element mounting plates. E3925 version will require the centre pillar nuts to be removed.

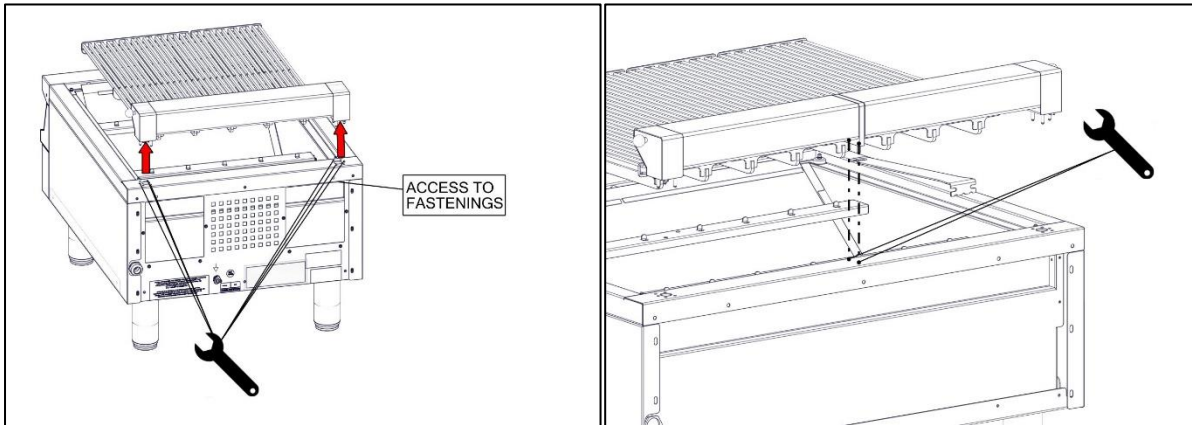

9.5.5 Feed cables from front of unit and out at rear cable entry hole to enable element assembly lift off as shown below.

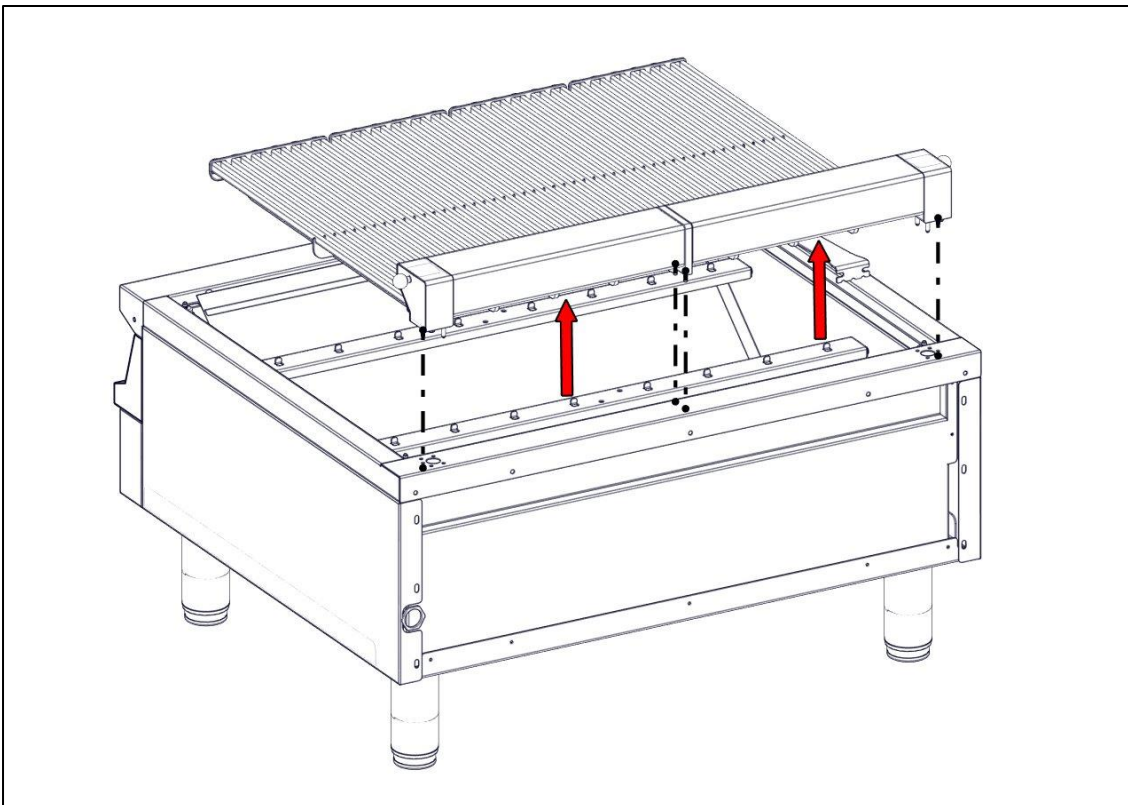

9.6 CIRCUIT DIAGRAMS

9.6.1 E3925 Circuit Diagram

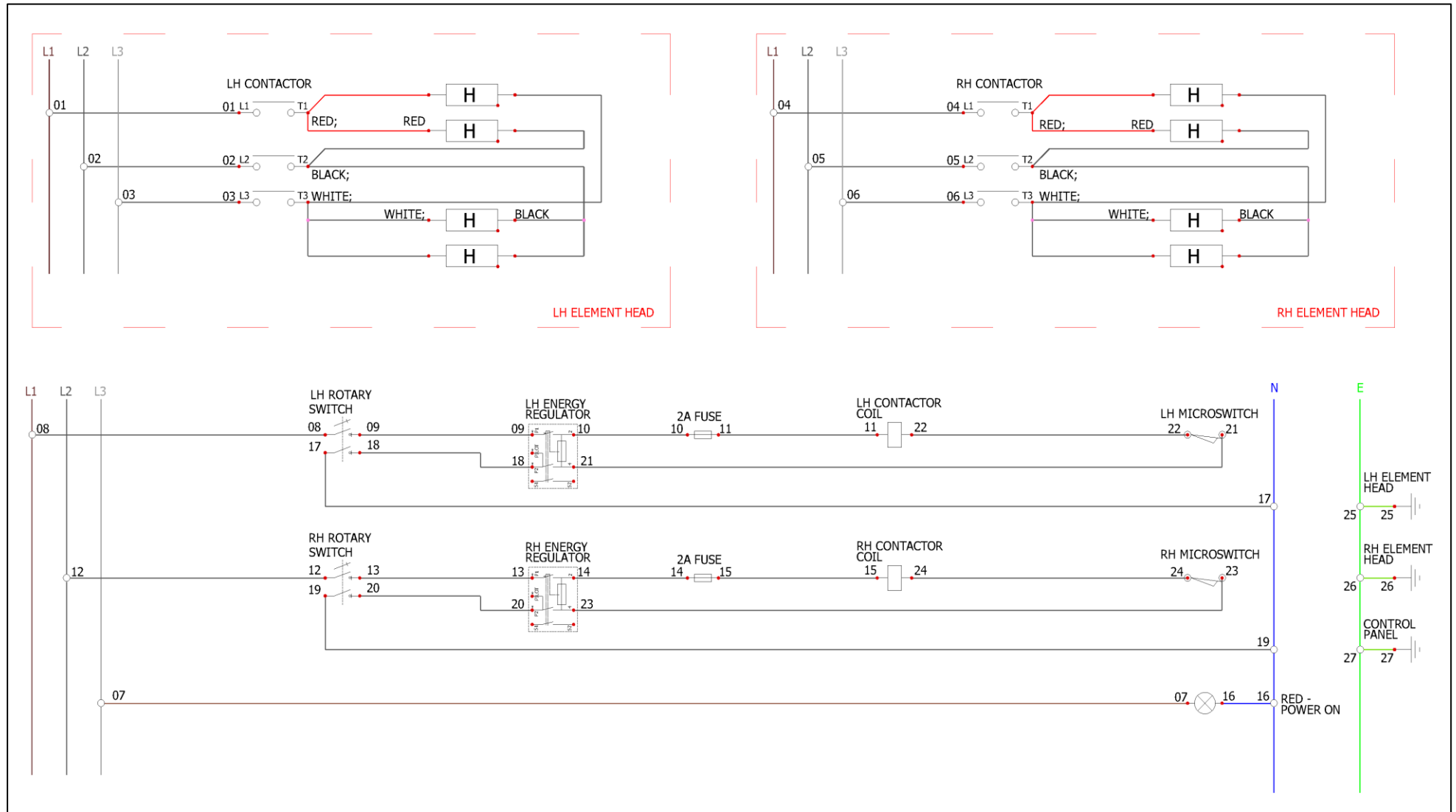

9.6.2 E3625 Circuit Diagram

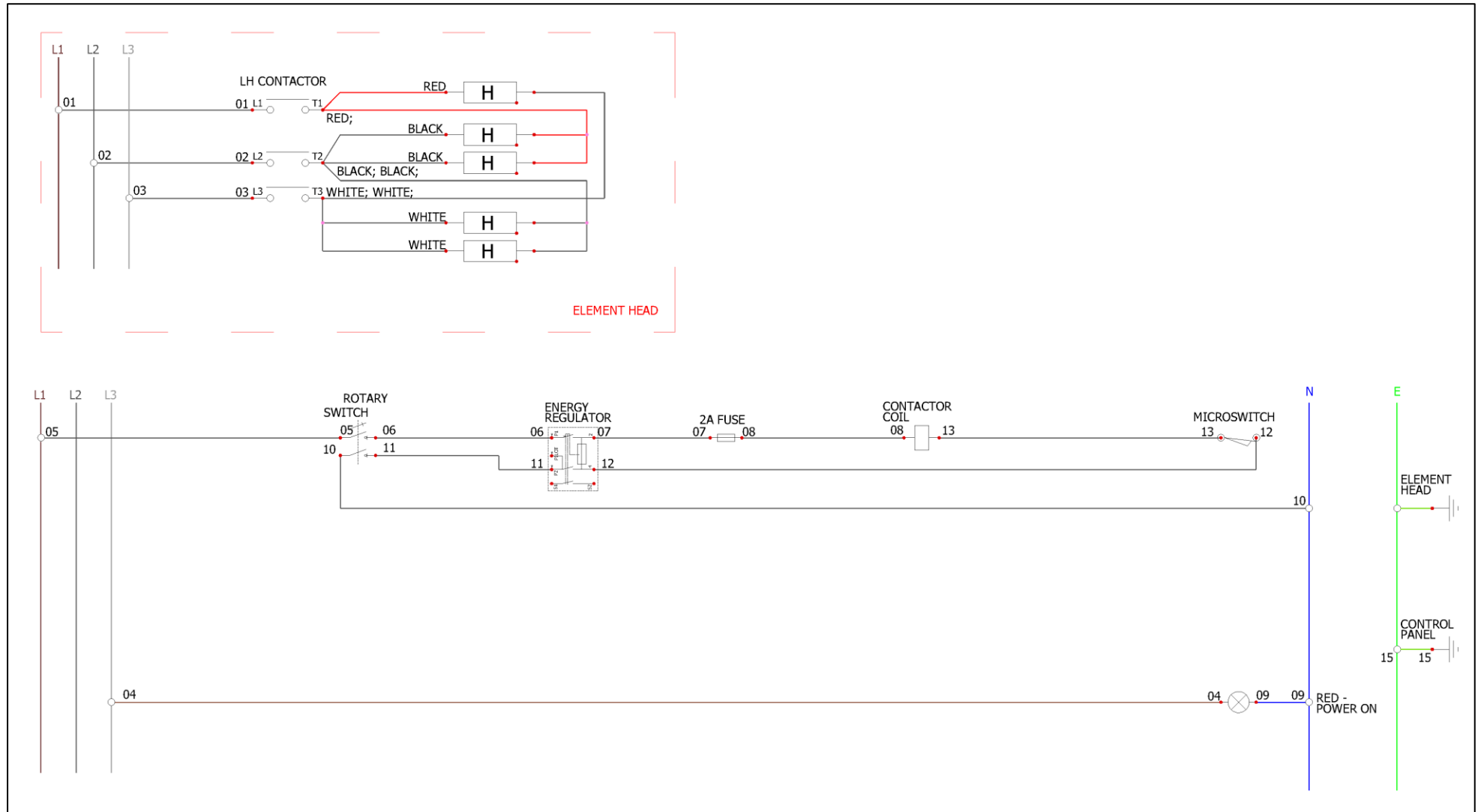

9.7 WIRING DIAGRAMS

9.7.1 E3925 Wiring Diagram

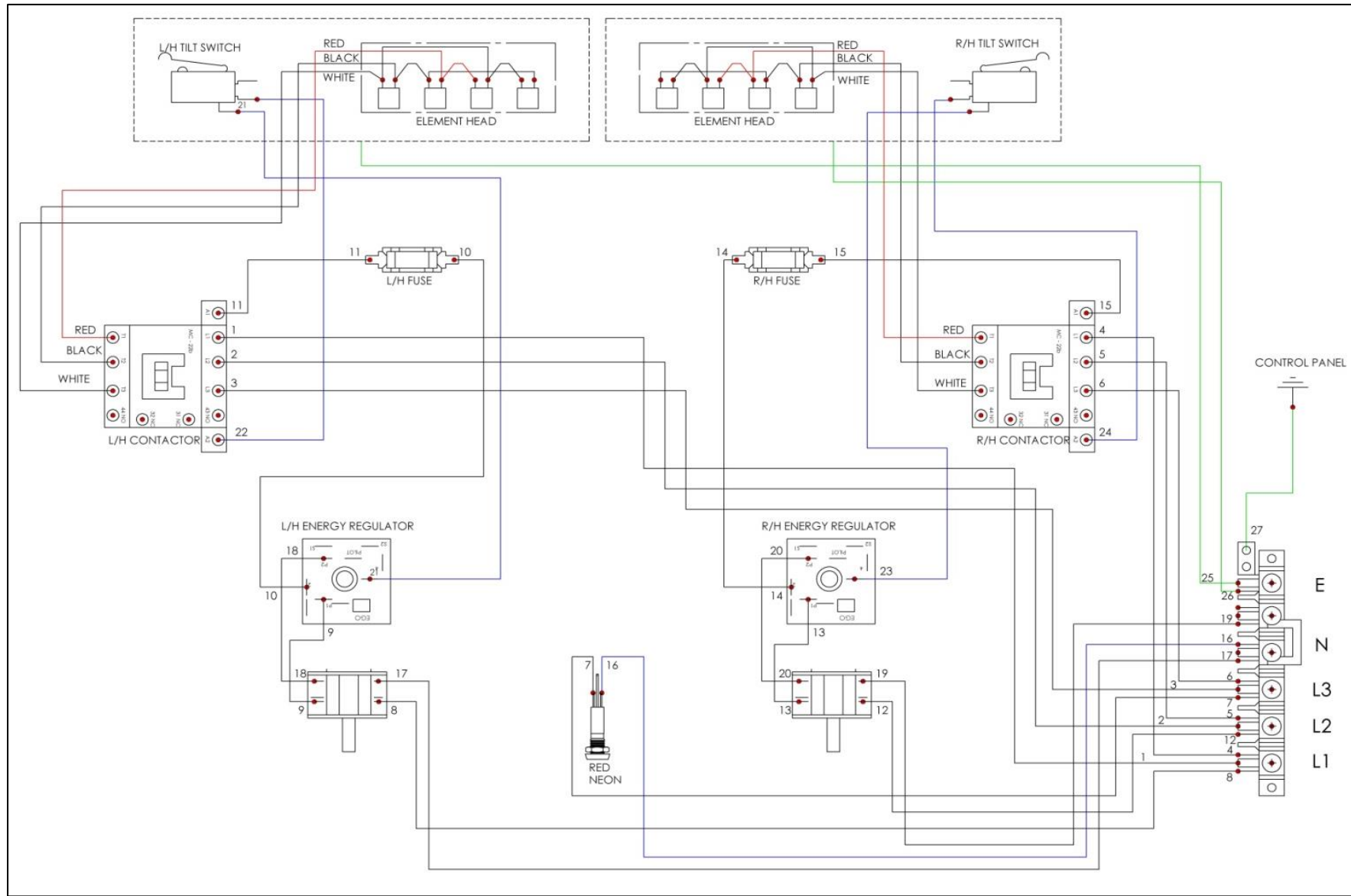

9.7.2 E3625 Wiring Diagram

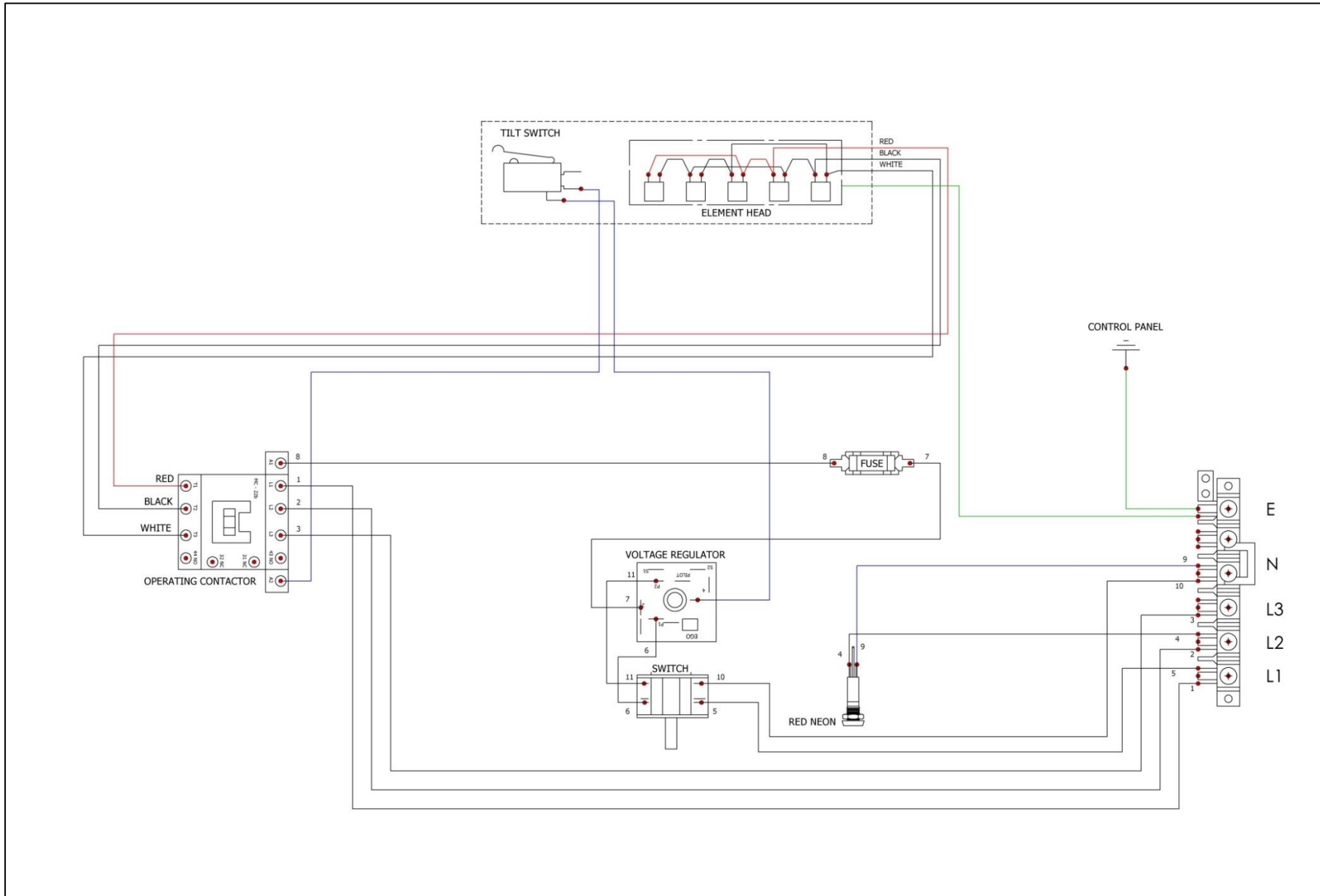

10.0 ACCESSORIES

E3625

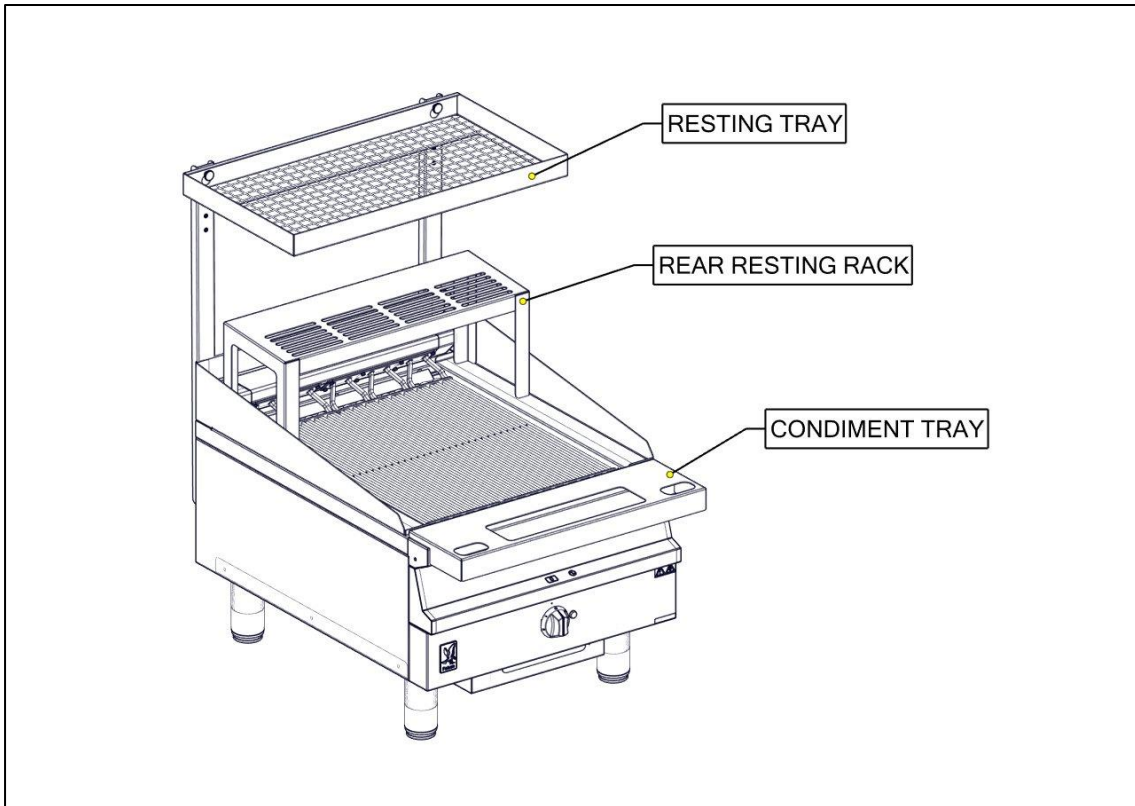

E3925

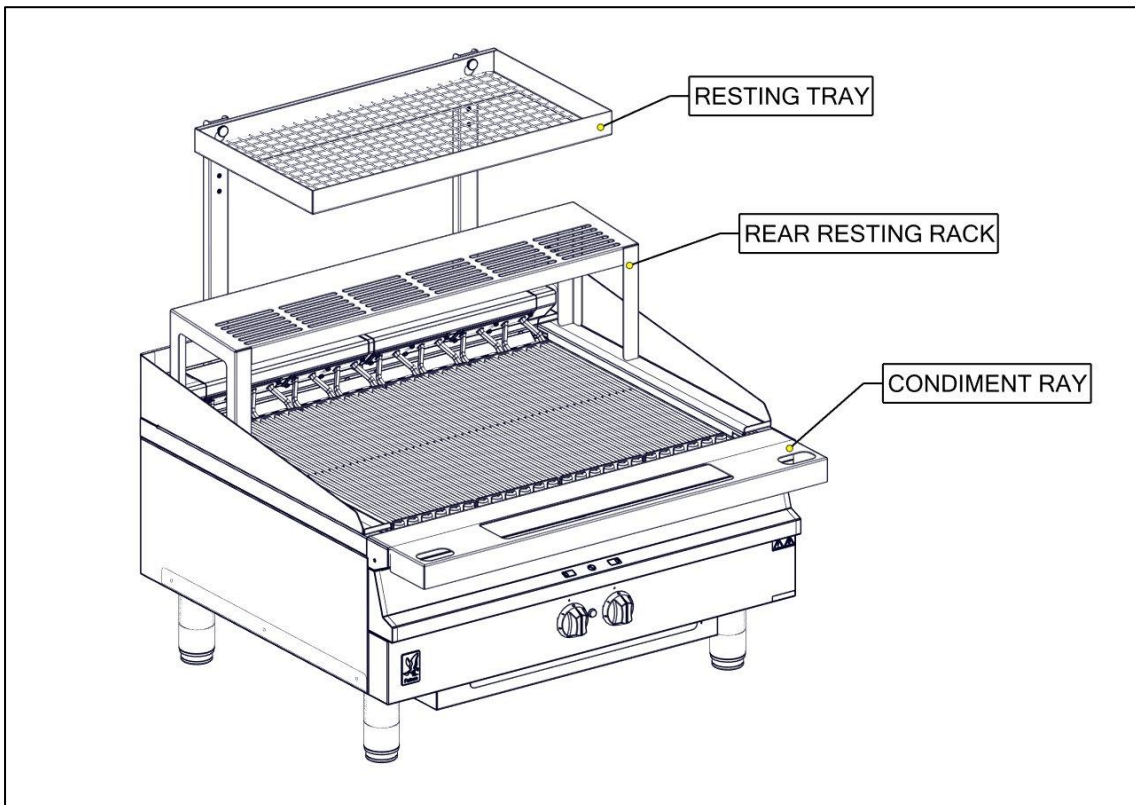

11.0 FAULT FINDING

FAULT	POSSIBLE CAUSES	REMEDY	USER	*ENG
Unit will not turn ON	No power to unit	Check mains power is connected and turned on	✓	
Heating elements will not turn ON	Element not fully down.	Ensure element is fully lowered	✓	
	Fuse has blown	Check Fuse behind control panel (section 7.2.1) and replace as necessary.		✓

PROBLEM	POSSIBLE CAUSES	REMEDY	USER	*ENG
Food keeps burning	Dial setting too high	Lower dial setting	✓	
Appliance is too hot	Dial left on 'Clean' setting for too long.	Only use clean setting for short periods and only when cleaning the appliance.	✓	
	Appliance being left on higher settings when not in use.	If the appliance is not in use, turn the dial to a lower setting to maintain element temperature.	✓	
Cooking zone not getting hot enough	Incorrect dial setting	Turn the dial to a higher setting.	✓	
	Unable to select setting 5.	Check keyway is fitted correctly as shown on page 15	✓	
	Faulty energy regulator	Replace energy regulator		✓

*ENG Service engineer only.

12.0 SPARE PARTS

PART DESCRIPTION	SPARES NUMBER
Power neon red	730962010
Control Knob & Stop Kit	735950017
Terminal Block	731000006
Contactator	734510010
Switch	732910481
Micro switch	735960015
Cleaning tool scraper	733650009
Energy regulator	737630011
E3625 Control panel	735950002
E3625 PTFE front & rear liner set	735950014
E3625 Element	735950000
E3625 Drip Tray	735950016
E3925 Control panel	735960002
E3925 PTFE front & rear liner set	735960022
E3925 Element	735960000
E3925 Drip Tray	735960024

When ordering spare parts please quote the following:

Model Number

Serial number

This information will be found on data plate attached to the appliance
Visit our website for further spare parts and information.

13.0 SERVICE INFORMATION

SERVICE INFORMATION

This unit carries an extensive mainland UK warranty. The warranty is in addition to and does not change your statutory or legal rights.

The warranty policy can be found on our website which details the conditions of the warranty and the exclusions.

<https://www.falconfoodservice.com/info-centre/policy>



Service calls to equipment under warranty will be carried out in accordance with the conditions of sale.

Warranty calls can be made between 8:30 am and 5:00 pm weekdays only.

To ensure your warranty enquiry is handled as efficiently as possible, ensure you have the following appliance information prior to calling us:

1. Model number – found on data plate
2. Serial number – found on data plate
3. Brief description of the issue

To contact Falcon for a warranty issue dial (UK only) 01786 455 200 and select Warranty Issues from the menu.