

# AMH910 6.5kW 30Amp

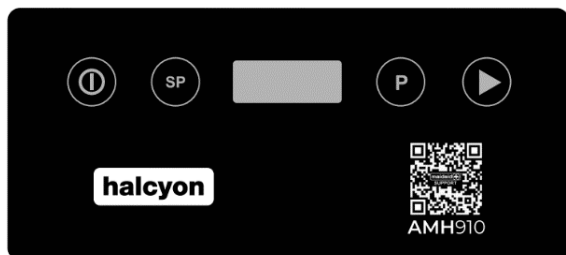

**Buttress Group Ltd.**  
Top Station Road, Brackley,  
Northants NN13 7UG, UK



	Overall dimensions (W x D x H)	mm	<b>633 x 750 x 1485* (1934)†</b>
	Packaging dimensions (W x D x H)	mm	<b>760 x 840 x 152</b>
↙	Gross weight	Kg	<b>90</b>
	Net weight	Kg	<b>80</b>
	Cubic volume	m <sup>3</sup>	<b>0.45</b>
	Rack size	mm	<b>500 x 500</b>
☒	Door opening	mm	<b>420</b>
	Max useable height	mm	<b>400</b>
	Rack guide rails		<b>inox-side wings in composite</b>
	Body construction		<b>single skin</b>
	Tank construction		<b>moulded</b>
🔥	Tank volume	L	<b>15</b>
	Tank heating element	kW	<b>2.0</b>
	Surface scrap trays		<b>composite (2.5mm mesh)</b>
🔧	Wash arms		<b>parallel (quick release)</b>
	Wash pump type		<b>dual flow</b>
	Wash pump power	kW	<b>0.5</b>
	Wash temperature	°C	<b>55 - 60 (adjustable)</b>
	Boiler type		<b>atmospheric</b>
🔧	Boiler volume	L	<b>7</b>
	Breaktank		<b>yes</b>
	Boiler heating element	kW	<b>6.0</b>
🔧	Rinse booster pump		<b>yes</b>
	Rinse booster pump power	kW	<b>0.15</b>
	Rinse temperature	°C	<b>70 - 82 (adjustable)</b>
	Rinse arms		<b>parallel (quick release)</b>
🚰	Drain system		<b>partial drain</b>
	Drain filter		<b>double filter</b>
	Drain pump		<b>yes</b>
💧	Rinse aid dispenser	peristaltic	<b>yes</b>
	Detergent dispenser	peristaltic	<b>yes</b>
	Water consumption per cycle	L	<b>1.5 - 2.0</b>
🍷	Inlet water pressure	bar	<b>0.5 - 6.0</b>
	Fast program (PR2)	sec	<b>100</b>
	Total programs	programs	<b>5</b>
	Total power	kW	<b>6.5</b>
⚡	Electric connection	V-Ph-Hz	<b>230-240V 1N 50Hz</b>
	Alternative		<b>4.5kW / 20A</b>
	Fuse	A	<b>30</b>
🔌	Water softener		<b>no</b>



## Supplied with

Dish rack	1
Flat rack	1
Cutlery rack	1
Electric cable	1
Drain hose	1
Fill hose	1

\*Minimum height (+60mm with adjustable feet)

†Minimum height with hood open (+60mm with adjustable feet)

# AMH910 6.5kW 30Amp



**Buttress Group Ltd.**  
 Top Station Road, Brackley,  
 Northants NN13 7UG, UK

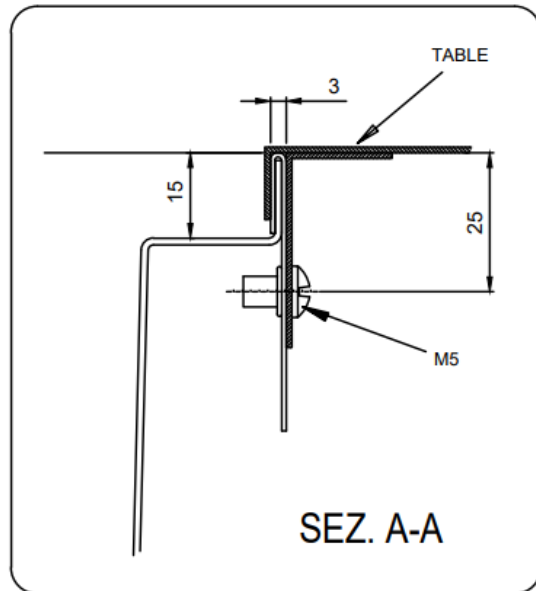
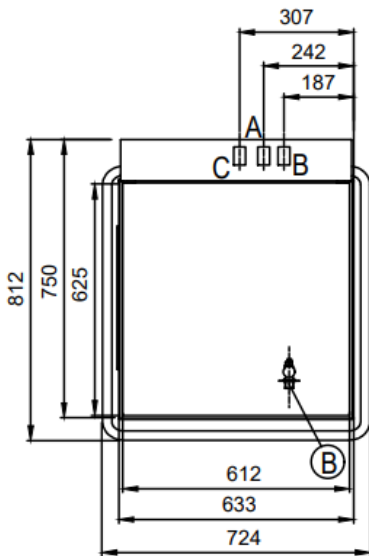
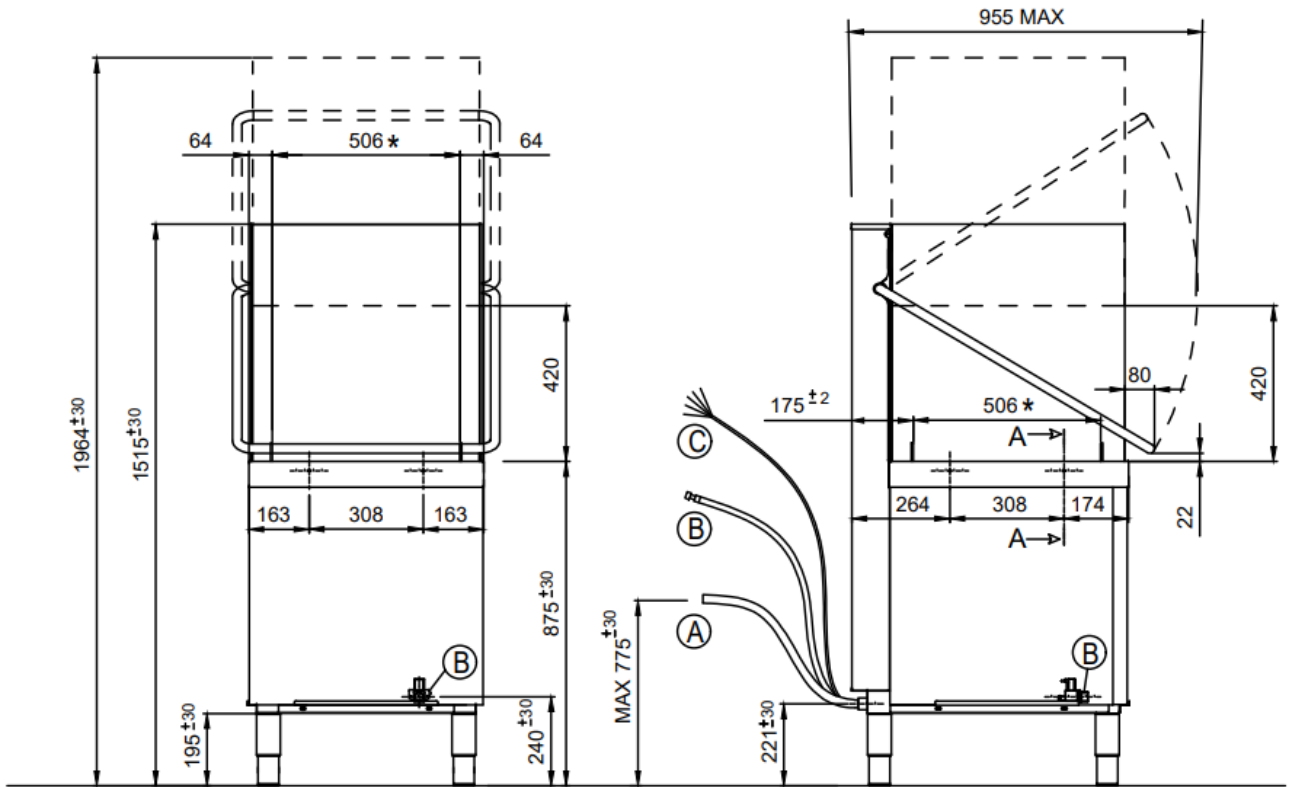

A		∅ 32 mm
B		G 3/4"
C		Power supply

\*Available space for basket on the basket carrier.  
 All services must be within 1 metre

T: 03451 308 070  
 E: sales@maidaid-halcyon.co.uk  
 Issue: 1.0